

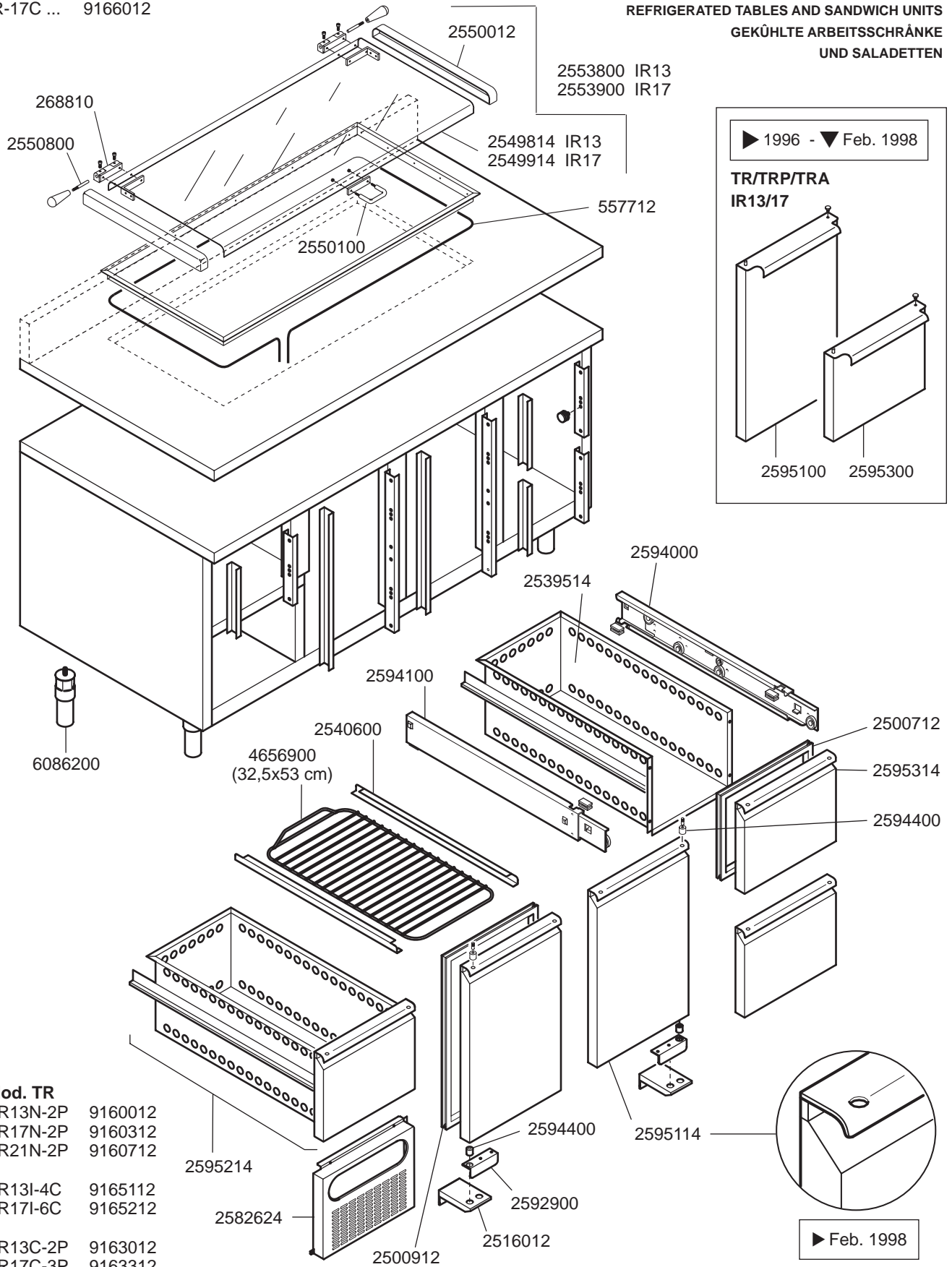

**Mod. IR ...**  
 IR-13C ... 9165712  
 IR-17C ... 9166012

**TAVOLI ARMADI ED INSALATIERE REFRIGERATI**  
**TABLES ET SALADE-CHEF REFRIGEREES**  
**REFRIGERATED TABLES AND SANDWICH UNITS**  
**GEKÜHLTE ARBEITSSCHRÄNKE**  
**UND SALADETTEN**



**Mod. TR**  
 TR13N-2P 9160012  
 TR17N-2P 9160312  
 TR21N-2P 9160712  
  
 TR13I-4C 9165112  
 TR17I-6C 9165212  
  
 TR13C-2P 9163012  
 TR17C-3P 9163312

	ELABORATO:	APPROVATO:	GRUPPO:	DENOMINAZIONE:		
	G.Z.		Tavoli arm./Insalatiere refrigerati	Mobile		
	DATA:	DATA:	PARTICOLARE:	REV. N.	DEL	DISEGNO N.
	28 Mag. 99	28 Mag. 99	Disegno esploso per ricambi	▼ Z00	▼ 9905	▼ 1.1.04.TAR
SOST. DIS.						

**Mod. IR ...**  
 IR-13C ... 9165712  
 IR-17C ... 9166012

**Mod. TR**  
 TR13N-2P 9160012  
 TR17N-2P 9160312  
 TR21N-2P 9160712

TR13I-4C 9165112  
 TR17I-6C 9165212

TR13C-2P 9163012  
 TR17C-3P 9163312

**TAVOLI ARMADI ED INSALATIERE REFRIGERATI**  
**TABLES ET SALADE-CHEF REFRIGEREES**  
**REFRIGERATED TABLES AND SANDWICH UNITS**  
**GEKÜHLTE ARBEITSSCHRÄNKE**  
**UND SALADETTEN**

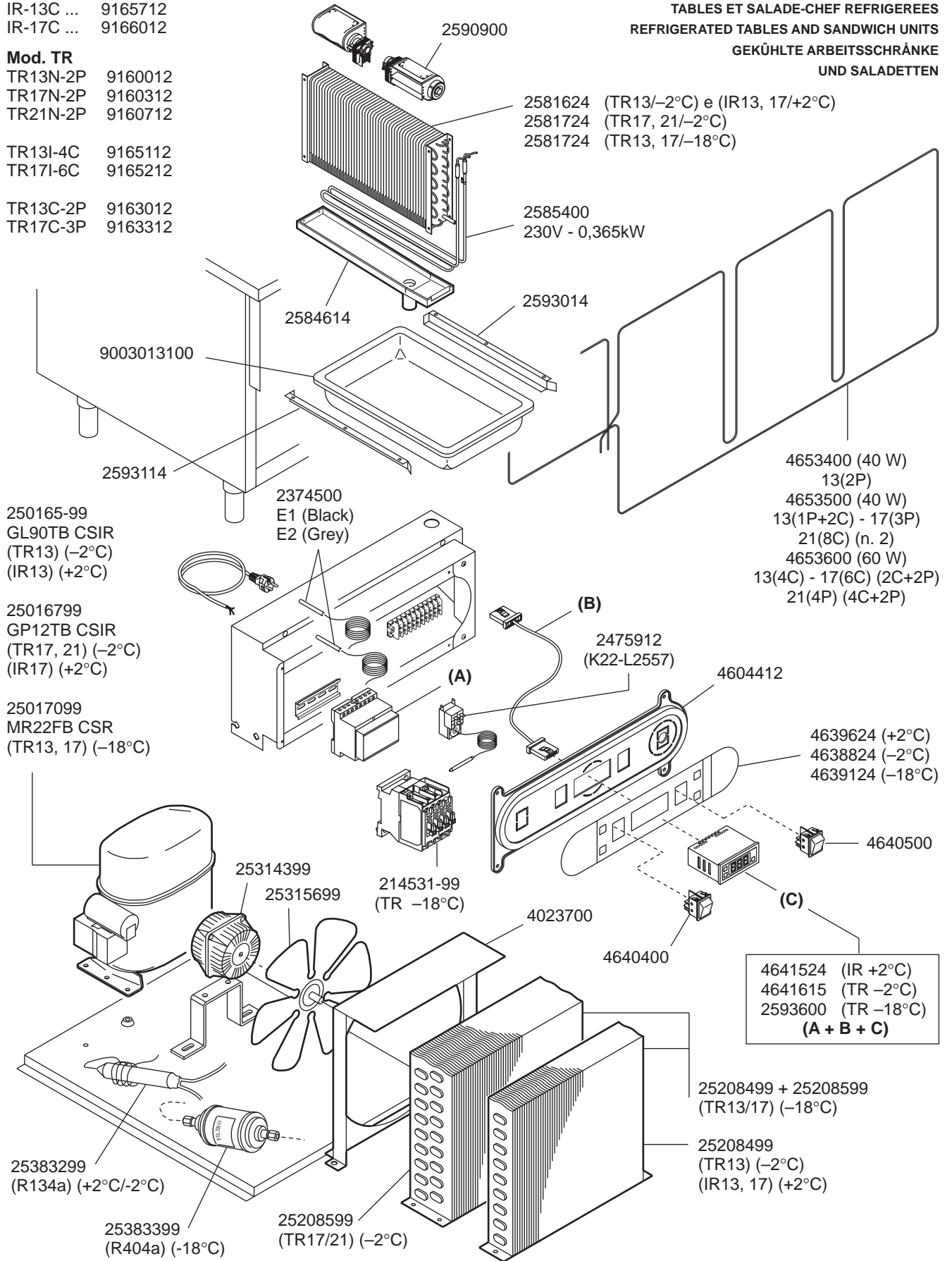

ELABORATO:	APPROVATO:	GRUPPO:	DENOMINAZIONE:		
G.Z.		Tavoli arm./Insalatiere refrigerati	Sistema refrigerante e impianto elettrico		
DATA:	DATA:	PARTICOLARE:	REV. N.	DEL	DISEGNO N.
28 Mag. 99	28 Mag. 99	Disegno esploso per ricambi	Z00	9905	1.1.05.TAR
SOST. DIS.					

TAVOLI ARMADI ED INSALATIERE REFRIGERATI  
 TABLES ET SALADE-CHEF REFRIGEREES  
 REFRIGERATED TABLES AND SANDWICH UNITS  
 GEKÜHLTE ARBEITSSCHRÄNKE  
 UND SALADETTEN

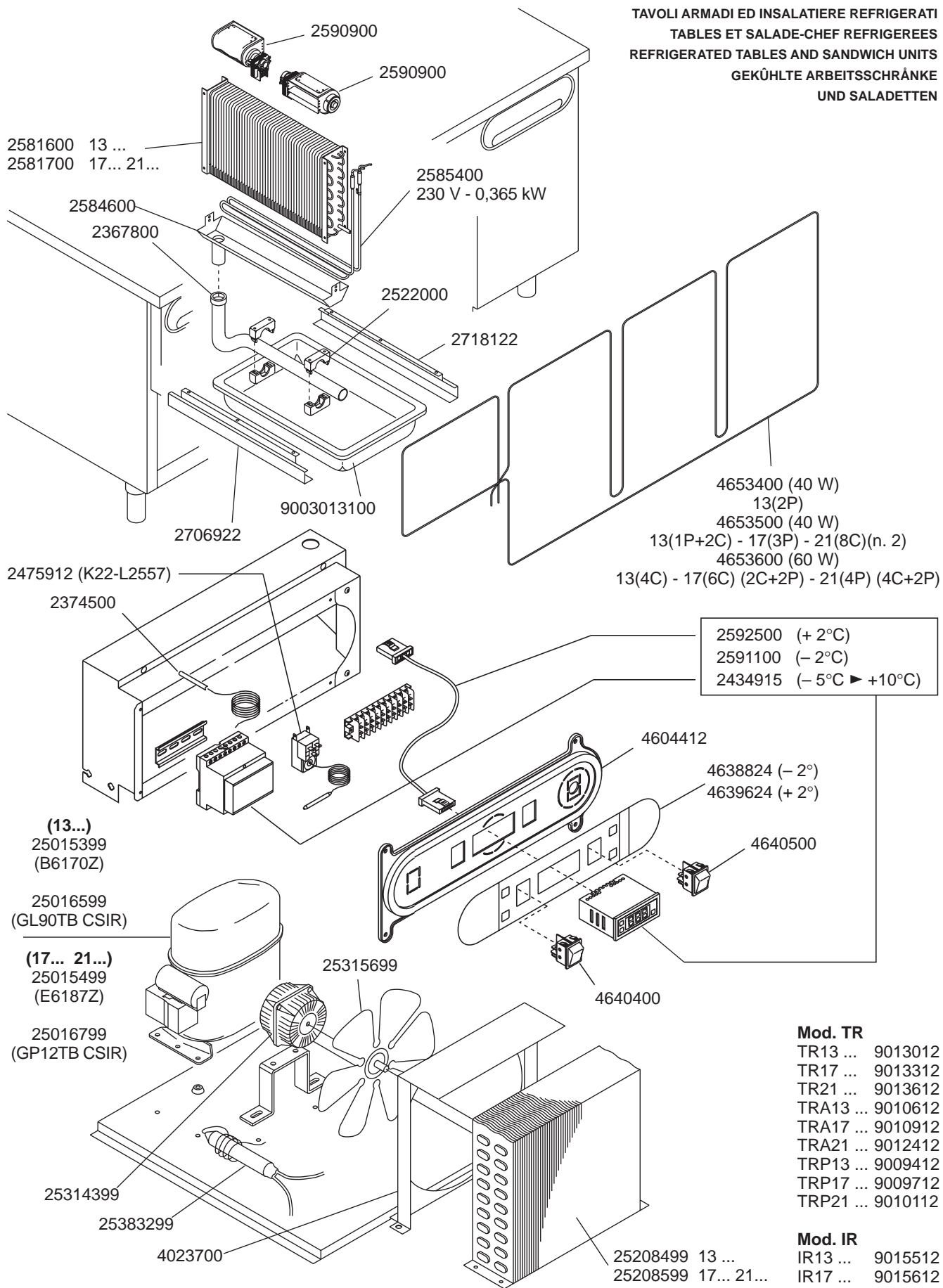

ELABORATO:	APPROVATO:	GRUPPO:	DENOMINAZIONE:		
		Tavoli e insalatiere refrigerati	Sistema refrigerante e impianto elettrico		
DATA:	DATA:	PARTICOLARE:	REV. N.	DEL	DISEGNO N.
10 Set 1995	10 Set 1995	Disegno esploso per ricambi	▼	▼	▼
SOST. DIS.		CE	Z01	9905	1.1.01.TIR

**Mod. TR**

TR13 ... 9013012  
 TR17 ... 9013312  
 TR21 ... 9013612  
 TRA13 ... 9010612  
 TRA17 ... 9010912  
 TRA21 ... 9012412  
 TRP13 ... 9009412  
 TRP17 ... 9009712  
 TRP21 ... 9010112

**TAVOLI ARMADI REFRIGERATI  
 TABLES REFRIGEREES  
 REFRIGERATED TABLES  
 GEKÜHLTE ARBEITSSCHRÄNKE**

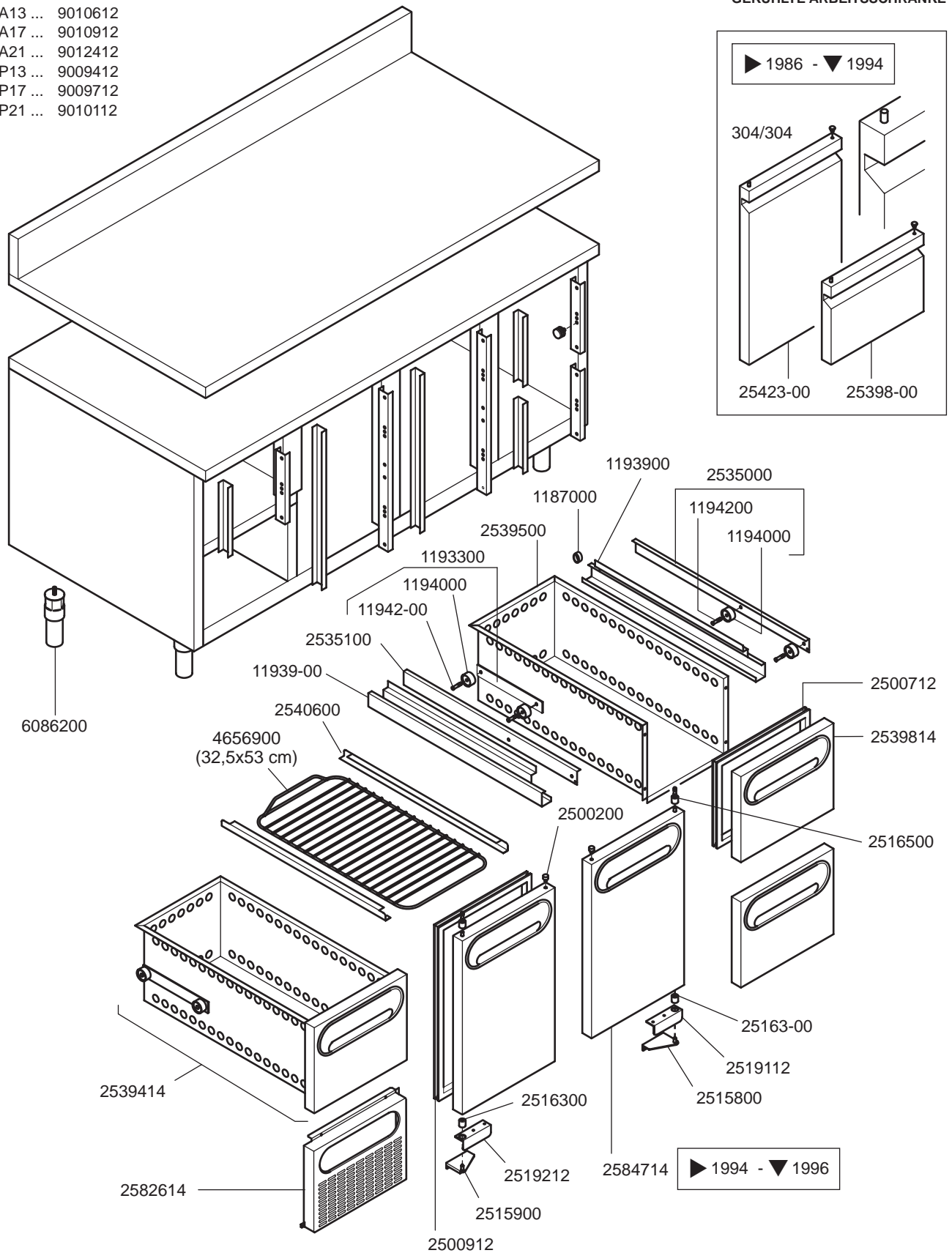

	ELABORATO:	APPROVATO:	GRUPPO:	DENOMINAZIONE:		
			Tavoli refrigerati	Mobile		
	DATA:	DATA:	PARTICOLARE:	REV. N.	DEL	DISEGNO N.
	10 Set 1995	10 Set 1995	Disegno esploso per ricambi	▼ Z01	▼ 9905	▼ 1.1.00.TAR
	SOST. DIS.					