

CUOCIWÜRSTEL ELETTRICI
ELECTRIC-HEATED SAUSAGE GRILL
GRILLES ELECTRIQUES
ELEKTROBEHEIZTE-ROSTBRÄTER
COCIDORES ELECTRICOS DE SALCHICHAS

CWE-42 10.401.789.10
 CWE-62 10.401.790.10

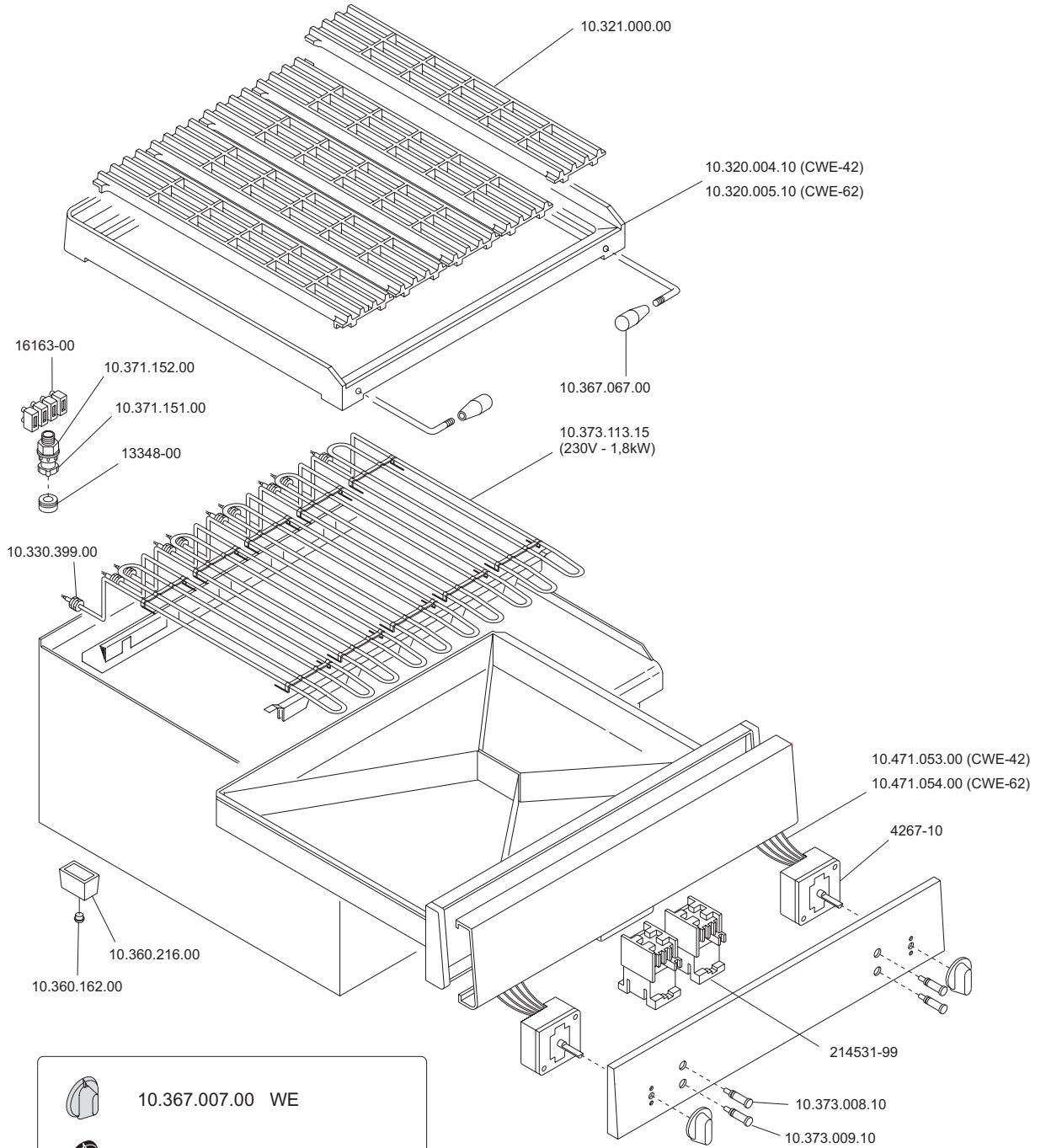

- 10.367.007.00 WE
- 10.367.022.00 HO, SC, ST, DA
- 10.367.030.00 MA
- 10.367.042.00 WA

<p>MARENO INDUSTRIE ALI spa Mareno di Piave (TV)</p>	ELABORATO:	APPROVATO:	GRUPPO:	DENOMINAZIONE:		
			Serie CE 600 (Snack)	Impianto elettrico e mobile		
	DATA:	DATA:	PARTICOLARE:	REV. N.	DEL	DISEGNO N.
	10 Sett 96	10 Sett 96	Disegno esploso per ricambi	▼	▼	▼
SOST. DIS.	P00 - 9609.3.6.25.CWE		P 0 0 - 9 6 0 9 . 3 . 6 . 2 5 . C W E			

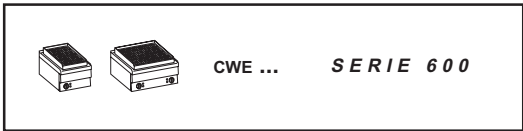

CUOCIWÜRSTEL ELETTRICI
 GRILLES ELECTRIQUES
 ELECTRIC-HEATED SAUSAGE GRILL
 ELEKTROBEHEIZTE-ROSTBRÄTER
 COCIDORES ELECTRICOS DE SALCHICHAS

CWE-42 10.401.789.20
 CWE-42/2 10.402.125.00

CWE-62 10.401.790.20
 CWE-62/2 10.402.132.00

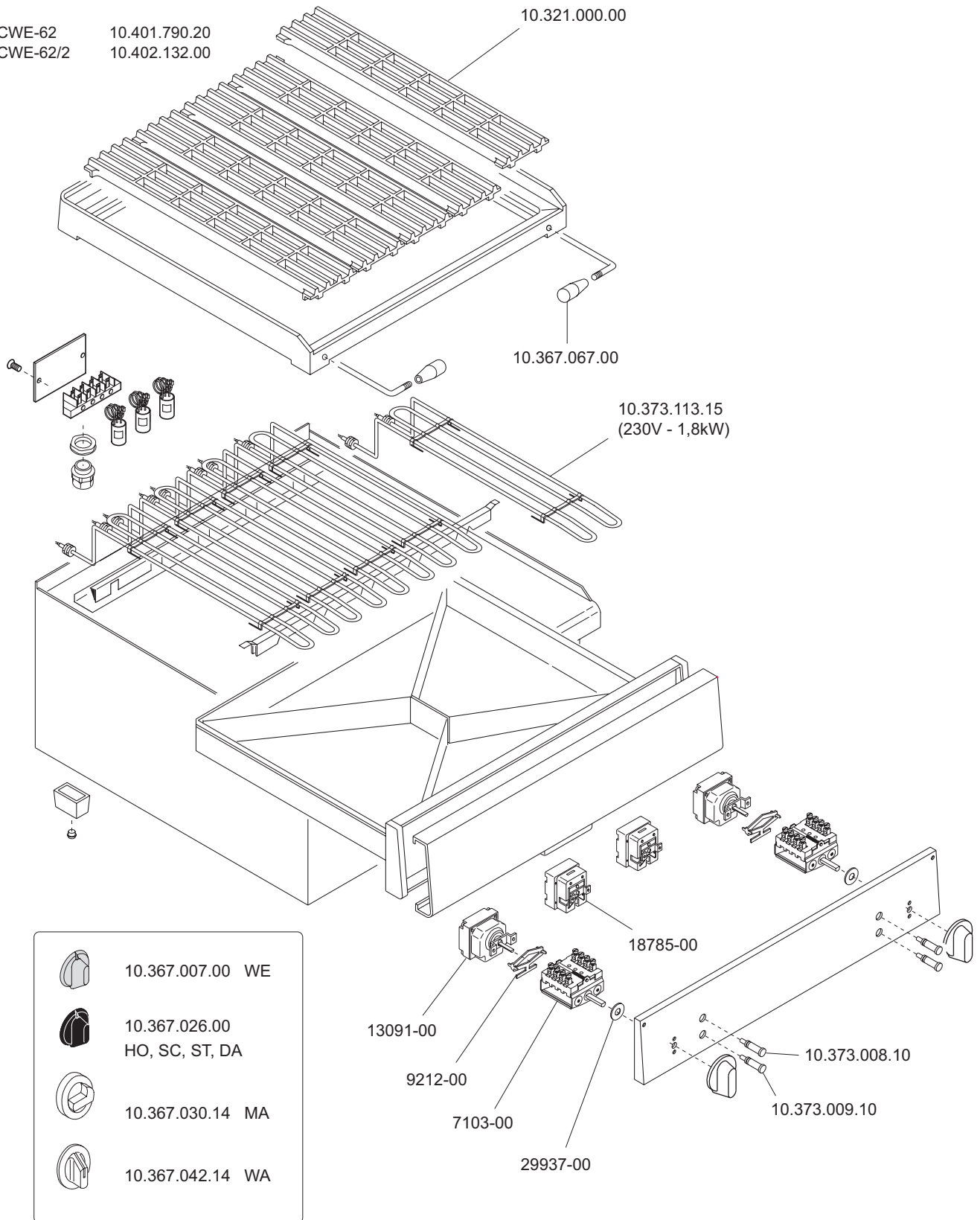

<p>MARENO INDUSTRIES ALI spa Mareno di Piave (TV)</p>	ELABORATO:	APPROVATO:	GRUPPO:	DENOMINAZIONE:		
	<i>Plumelle</i>		Serie CE 600 (snack)	Impianto elettrico e mobile		
	DATA:	DATA:	PARTICOLARE:	REV. N.	DEL	DISEGNO N.
	10 Gen 97	10 Gen 97	Disegno esploso per ricambi	▼	▼	▼
SOST. DIS.	Z00 - 9701.3.6.44.CWE		Z00 - 9701.3.6.44.CWE			

CUOCIWÜRSTEL ELETRICI
ELECTRIC-HEATED SAUSAGE GRILL
GRILLES ELECTRIQUES
ELEKTROBEHEIZTE ROSTBRÄTER

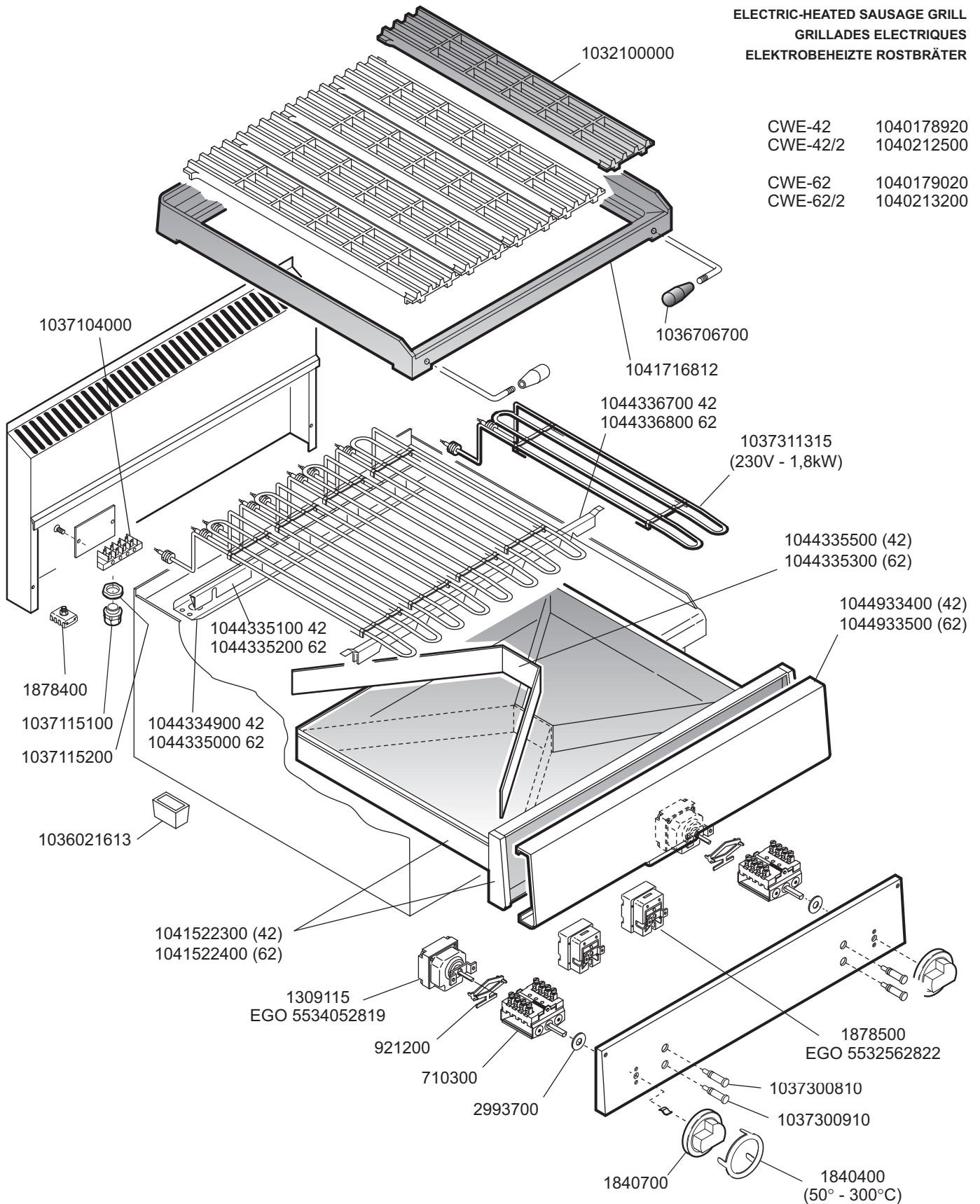

CWE-42 1040178920
 CWE-42/2 1040212500

CWE-62 1040179020
 CWE-62/2 1040213200

1036700700
 WE, RA, BA

1036702600
 HO, SC, ST, DA

1036703014
 MA, KU (*)

1036704214
 WA

<p>MARENO INDUSTRIE ALI spa Mareno di Piave (TV)</p>	ELABORATO:	APPROVATO:	GRUPPO:	DENOMINAZIONE:		
	G.Z.		Serie 600 Snack	Impianto elettrico - Mobile		
	DATA:	DATA:	PARTICOLARE:	REV. N.	DEL	DISEGNO N.
	10 Gen 1997	10 Gen 1997	Disegno esploso per ricambi	▼ Z02	▼ 0106	▼ 3.6.44.CWE
SOST. DIS.	Z01.0104.3.6.44.CWE					

CUOCIWÜRSTEL ELETRICI
ELECTRIC-HEATED SAUSAGE GRILL
GRILLES ELECTRIQUES
ELEKTROBEHEIZTE ROSTBRÄTER

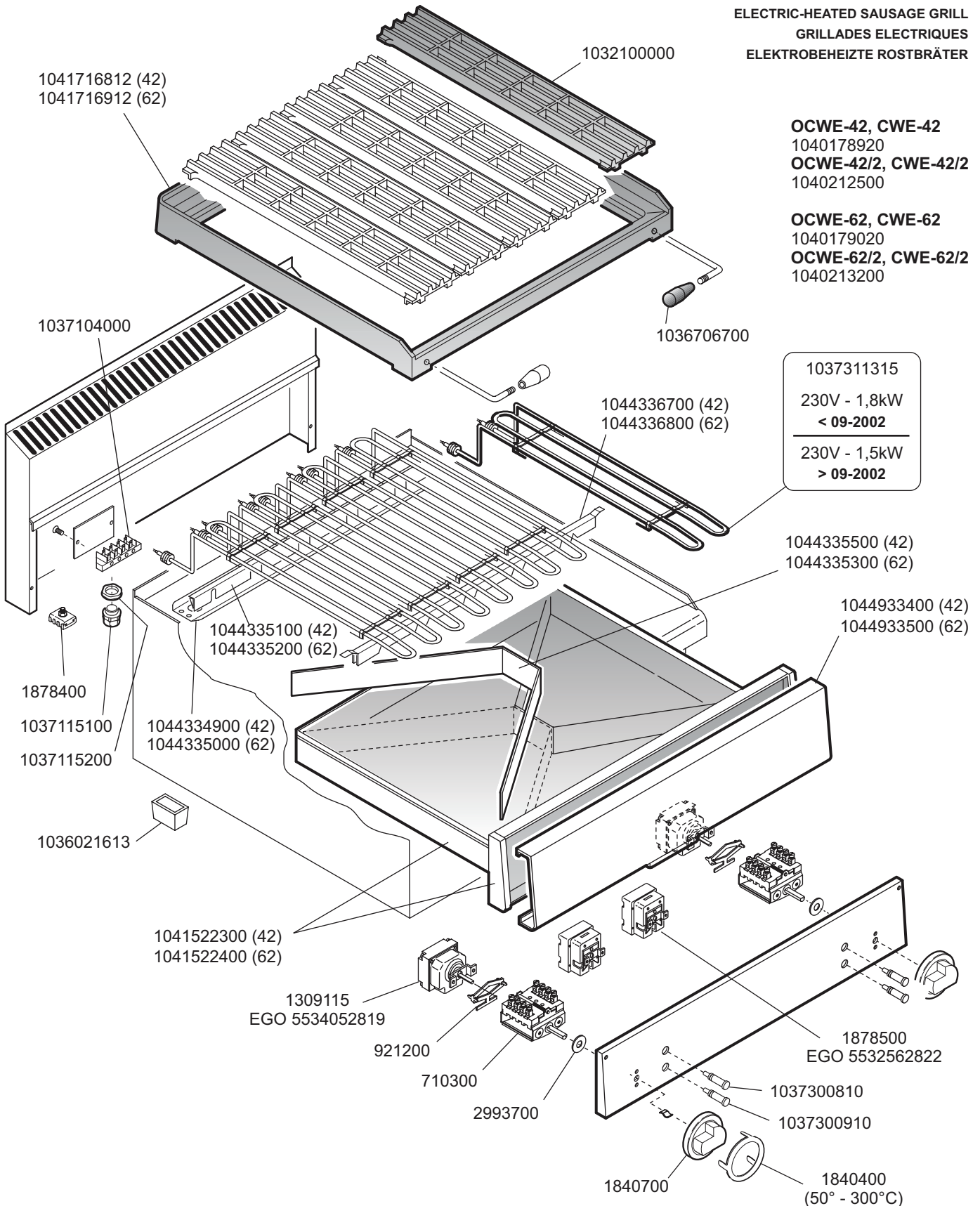

- CR0502150 (Metos)
CR0502150 (Bartscher)
CM188600 (Franke)
- 1036700700
WE, RA, BA
- 1036702600
HO, SC, ST, DA
- 1036703014
MA, KU (*)
- 1036704214
WA

 MARENO INDUSTRIE ALI spa Mareno di Piave (TV)	ELABORATO:	APPROVATO:	GRUPPO:	DENOMINAZIONE:		
	G.Z.		Serie 600 Snack	Impianto elettrico - Mobile		
	DATA:	DATA:	PARTICOLARE:	REV. N.	DEL	DISEGNO N.
	10 Gen 1997	10 Gen 1997	Disegno esploso per ricambi	▼	▼	▼
SOST. DIS.	Z02.0106.3.6.44.CWE		CE	Z03	0106	3.6.44

CUOCIWÜRSTEL ELETRICI
ELECTRIC-HEATED SAUSAGE GRILL
GRILLES ELECTRIQUES
ELEKTROBEHEIZTE ROSTBRÄTER

CWE-42 1040178920
 CWE-42/2 1040212500

CWE-62 1040179020
 CWE-62/2 1040213200

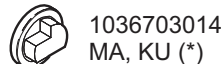
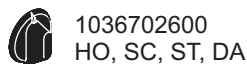
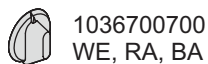
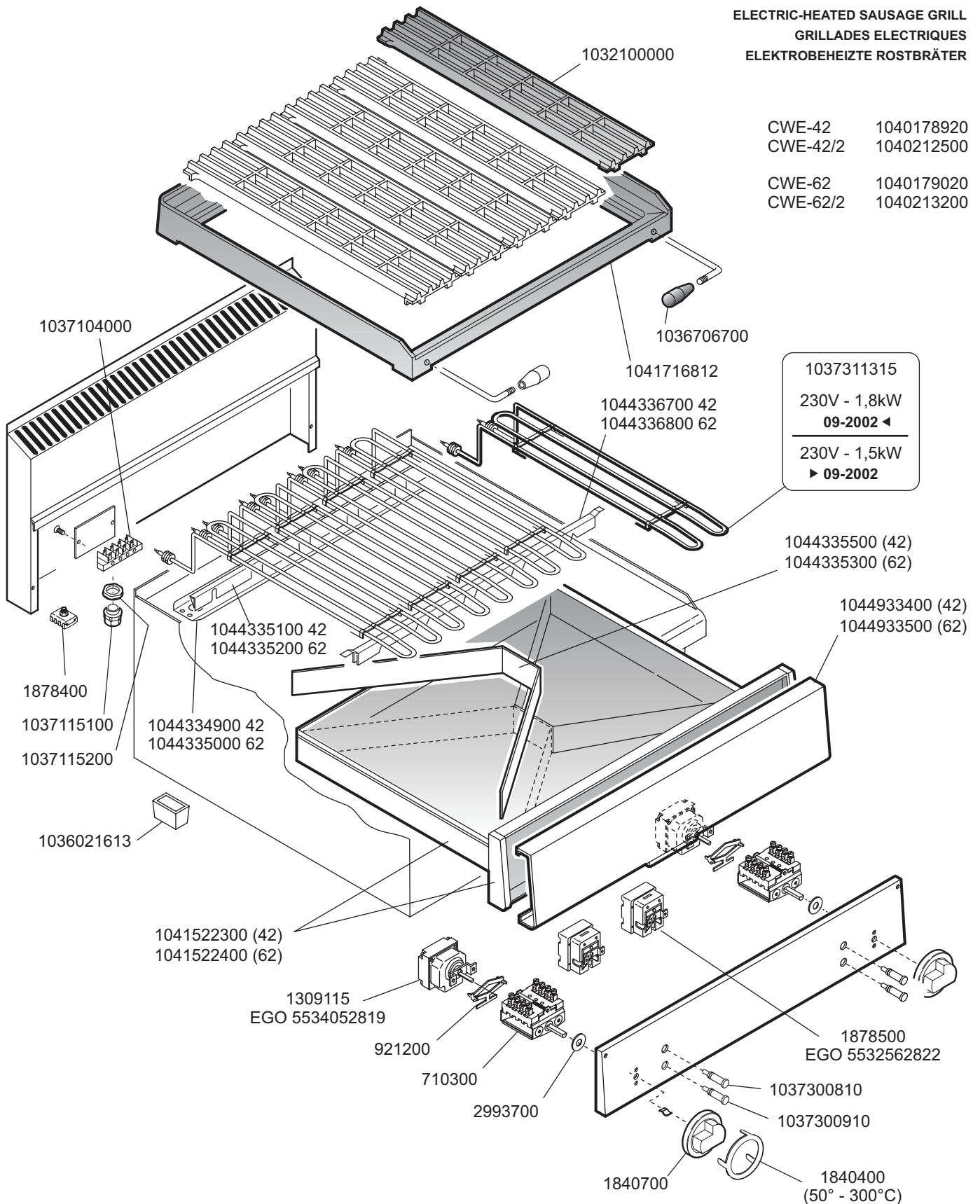

ELABORATO:	APPROVATO:	GRUPPO:	DENOMINAZIONE:		
G.Z.		Serie 600 Snack	Impianto elettrico - Mobile		
DATA:	DATA:	PARTICOLARE:	REV. N.	DEL	DISEGNO N.
10 Gen 1997	10 Gen 1997	Disegno esploso per ricambi	▼	▼	▼
SOST. DIS.	Z02.0106.3.6.44.CWE	CE	Z03	0503	3.6.44