

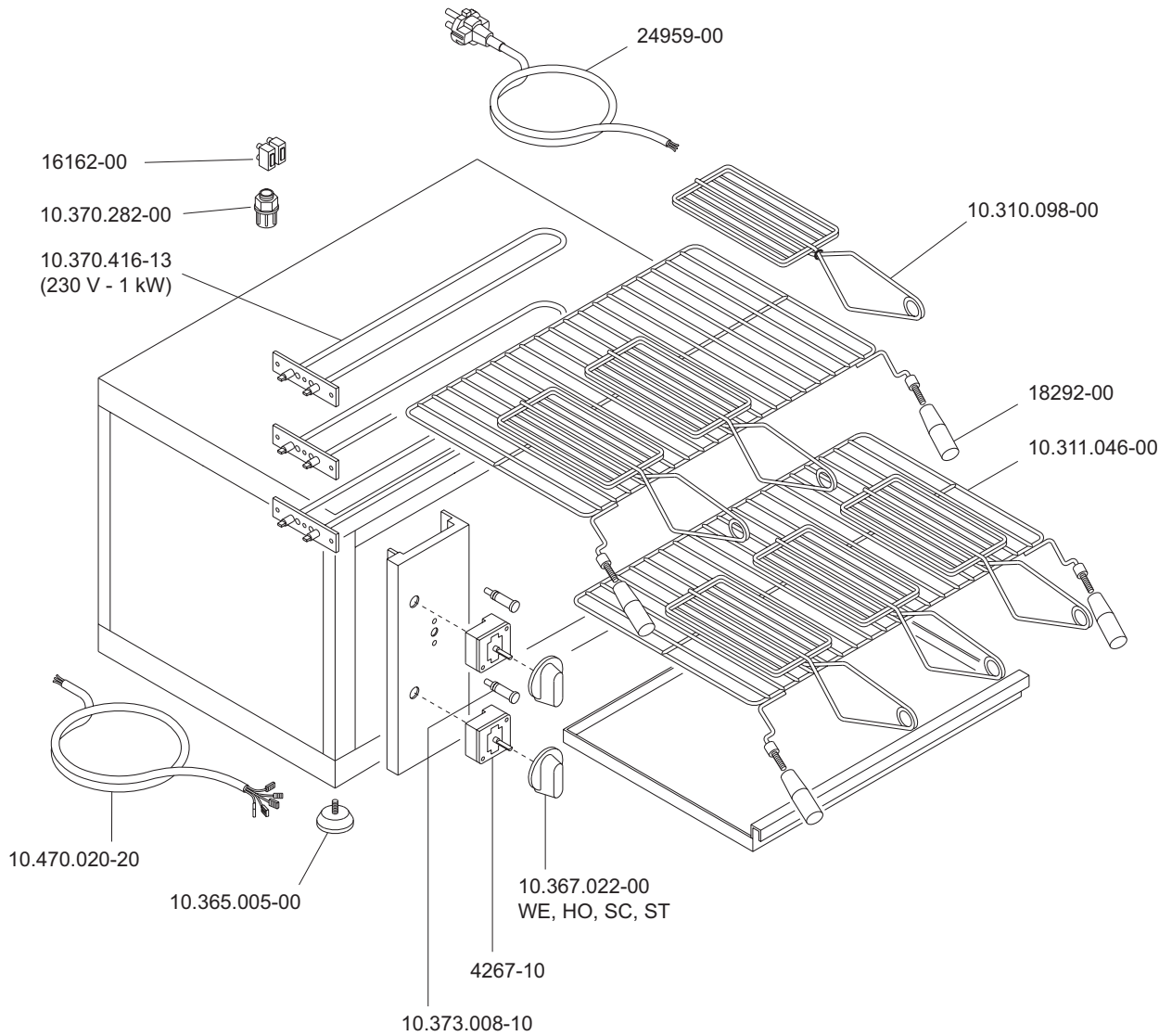



TSE-60M SERIE 600

TOSTIERA ELETTRICA
ELECTRIC HEATED TOASTER
TOASTEUR ELECTRIQUE
ELEKTROBEHEIZT TOASTER
TOSTADORA ELECTRICA

TSE-60M 10.401.057.10



 MARENO INDUSTRIES ALI spa Marenò di Piave (TV)	ELABORATO:	APPROVATO:	GRUPPO:	DENOMINAZIONE:		
	<i>Platt</i>		Serie CE 600 (Snack)	Impianto elettrico e mobile		
	DATA:	DATA:	PARTICOLARE:	REV. N.	DEL	DISEGNO N.
	10 Sett 96	10 Sett 96	Disegno esploso per ricambi	▼	▼	▼
SOST. DIS.	P01 - 9609.3.6.17.BSE		P 0 1 - 9 6 0 9 . 3 . 6 . 1 7 . T S E			

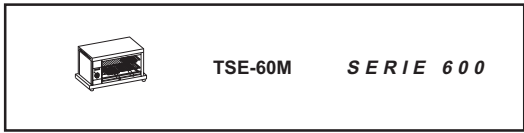

TSE-60M SERIE 600



TOSTIERA ELETTRICA
 ELECTRIC HEATED TOASTER
 TOASTEUR ELECTRIQUE
 ELEKTROBEHEIZT TOASTER
 TOSTADORA ELECTRICA

TSE-60M 10.401.057.20

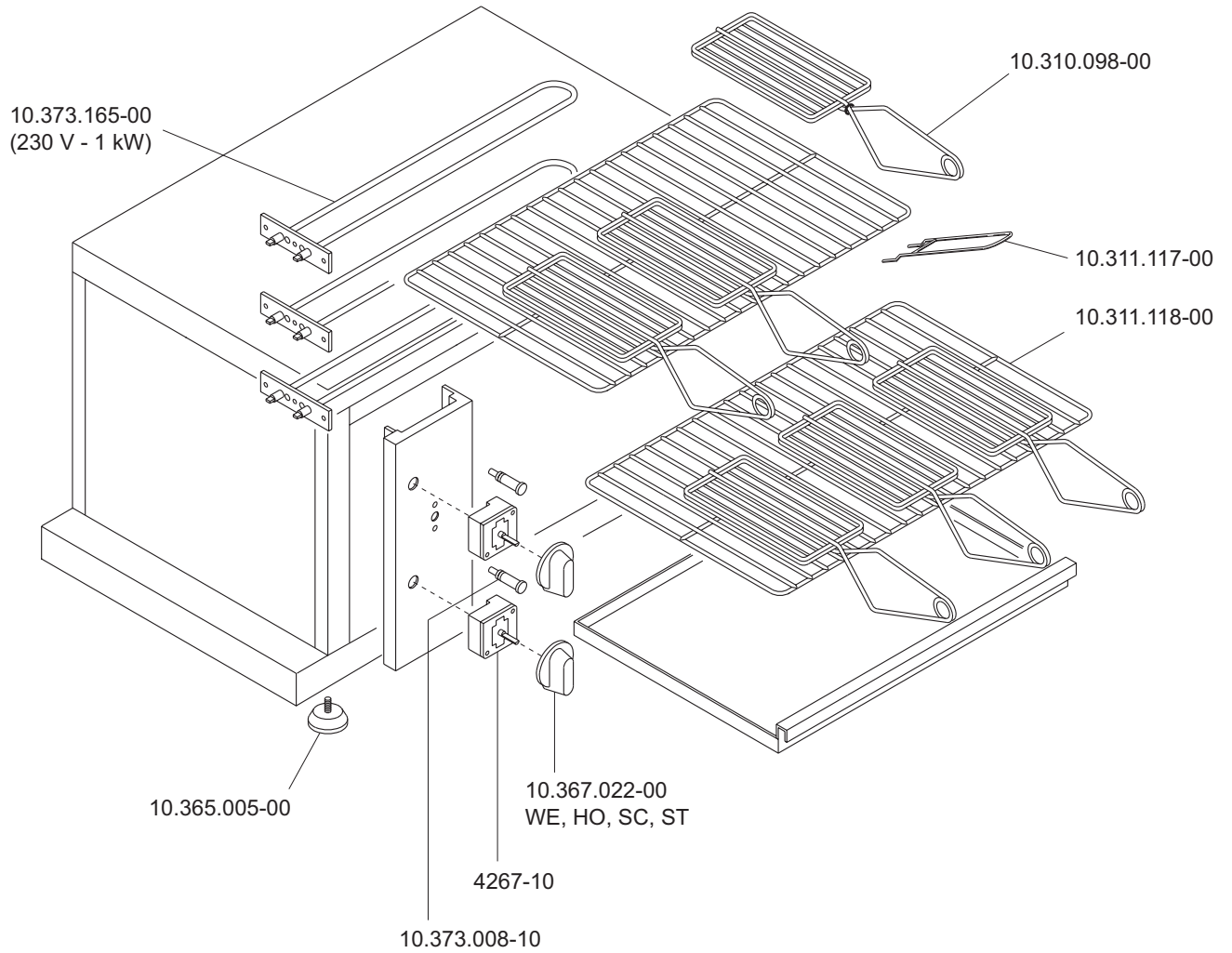

 MARENO INDUSTRIES ALI spa Mareno di Piave (TV)	ELABORATO:	APPROVATO:	GRUPPO:	DENOMINAZIONE:		
	<i>Plimati</i>		Serie CE 600 (snack)	Impianto elettrico e mobile		
	DATA:	DATA:	PARTICOLARE:	REV. N.	DEL	DISEGNO N.
	10 Nov 97	10 Nov 97	Disegno esploso per ricambi	▼	▼	▼
SOST. DIS.	P01 - 9609.3.6.17.BSE		Z 0 0 - 9 7 1 1 . 3 . 6 . 5 0 . T S E			

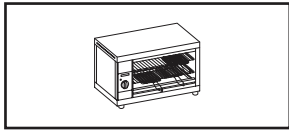

TOSTIERA ELETTRICA
ELECTRIC HEATED TOASTER
TOASTEUR ELECTRIQUES
ELEKTROBEHEIZTE TOASTER

TSE-60M 1040105730

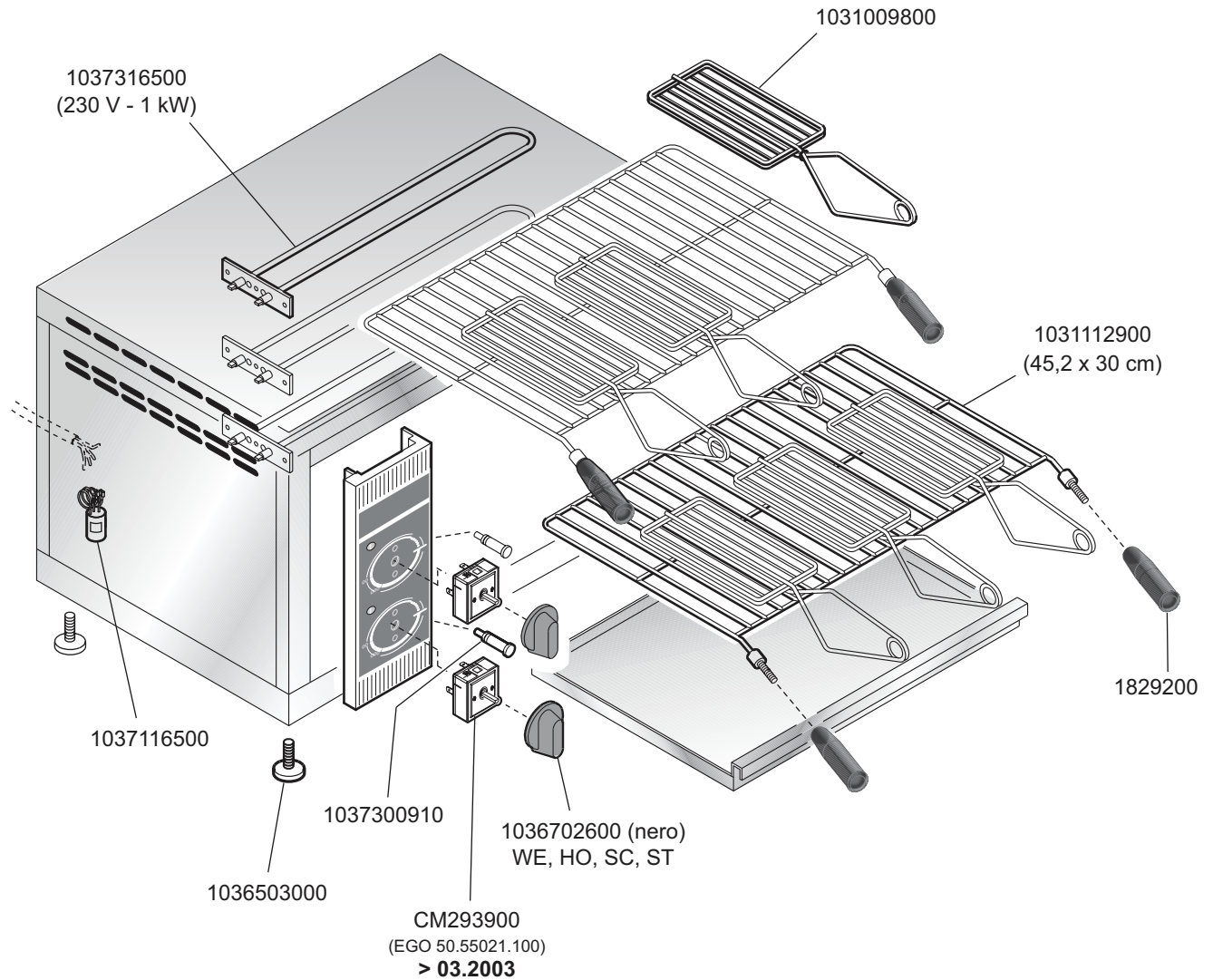

 MARENO INDUSTRIES ALI spa Mareno di Piave (TV)	ELABORATO:	APPROVATO:	GRUPPO:	DENOMINAZIONE:		
	G.Z.		Serie Snack	Impianto elettrico - Mobile		
	DATA:	DATA:	PARTICOLARE:	REV. N.	DEL	DISEGNO N.
	21 Mag 1999	21 Mag 1999	Disegno esploso per ricambi	▼ Z03	▼ 0803	▼ 3.6.50
SOST. DIS.	Z02.0105.3.6.50.TSE					