

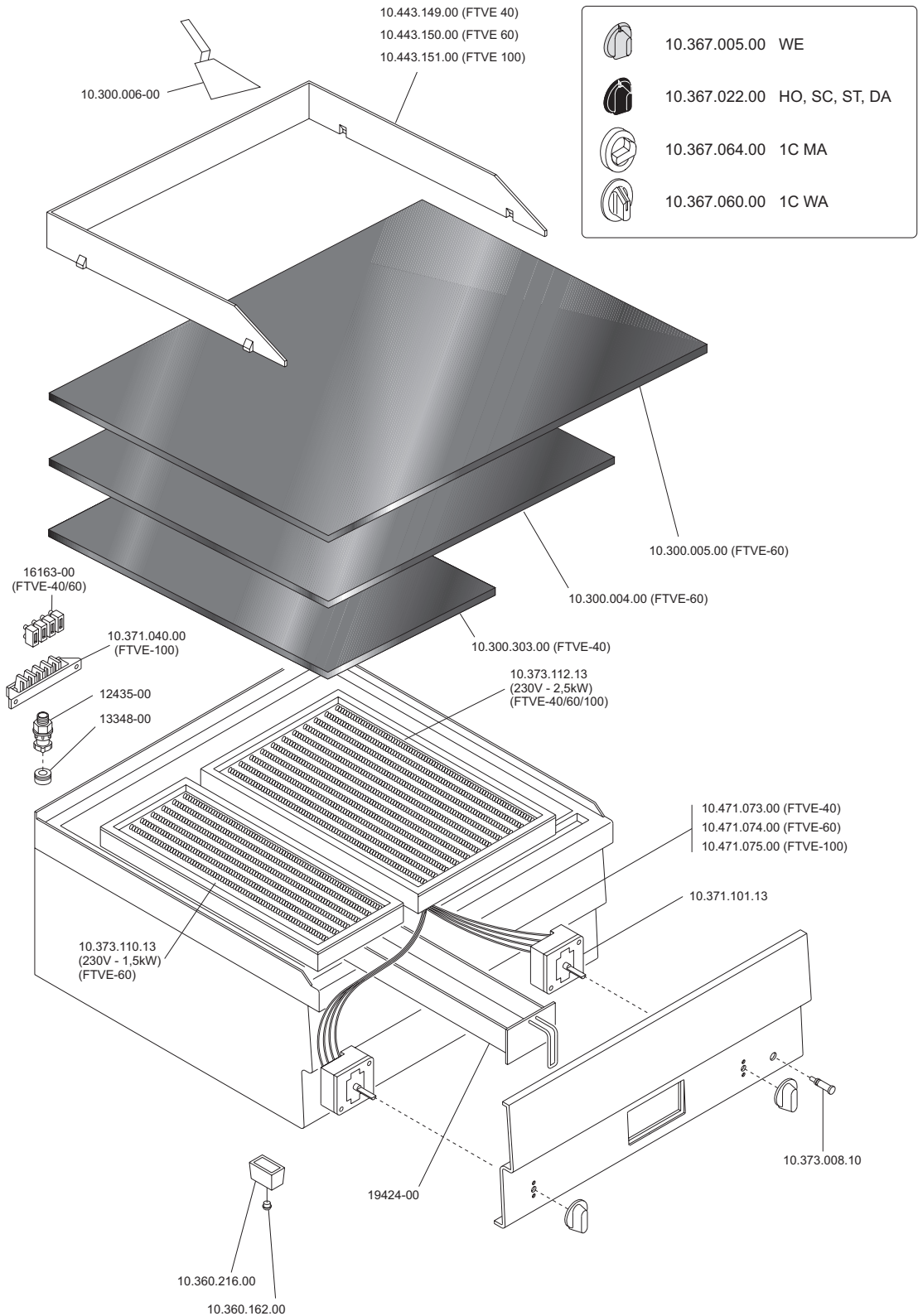

FRY TOP VETROCERAMICA ELETTRICI
CERAN HOBS FRY-TOPS ELECTRIC-HEATED
GRILLADES ELECTRIQUES AVEC PLAQUE VITROCERAMIQUE
ELEKTROBEHEIZTE BRAT- UND GRILLPLATTEN MIT CERAN-KOCHFLÄCHEN
FRY-TOPS ELECTRICAS CON PLANOS DE COCCION VITROCERAMICA

FTVE-40 10.401.739.10
 FTVE-60 10.401.740.10
 FTVE-100 10.401.741.10



 MARENO INDUSTRIE ALI spa Mareno di Piave (TV)	ELABORATO:	APPROVATO:	GRUPPO:	DENOMINAZIONE:		
	<i>Platt</i>		<i>Serie CE 600 (Snack)</i>	<i>Impianto elettrico e mobile</i>		
	DATA:	DATA:	PARTICOLARE:	REV. N.	DEL	DISEGNO N.
	10 Sett 96	10 Sett 96	<i>Disegno esploso per ricambi</i>	▼	▼	▼
SOST. DIS.	P00 - 9609.3.6.23.FTV		P 0 0 - 9 6 0 9 . 3 . 6 . 2 3 . F T V			



FRY TOP VETROCERAMICA ELETTRICI
CERAN HOBBS FRY-TOPS ELECTRIC-HEATED
GRILLADES ELECTRIQUES AVEC PLAQUE VITROCERAMIQUE
ELEKTROBEHEIZTE BRAT- UND GRILLPLATTEN MIT CERAN-KOCHFLÄCHEN
FRY-TOPS ELECTRICAS CON PLANOS DE COCCION VITROCERAMICA

FTVE-40 10.401.739.20
 FTVE-60 10.401.740.20
 FTVE-100 10.401.741.20

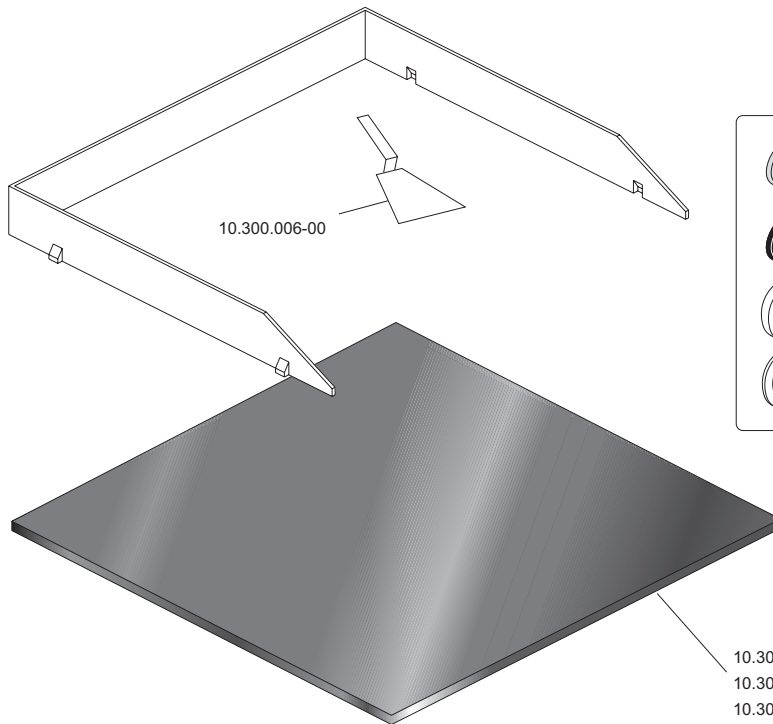

- 10.367.005.00 WE
- 10.367.022.00 HO, SC, ST, DA
- 10.367.064.00 MA (1C)
- 10.367.060.00 WA (1C)

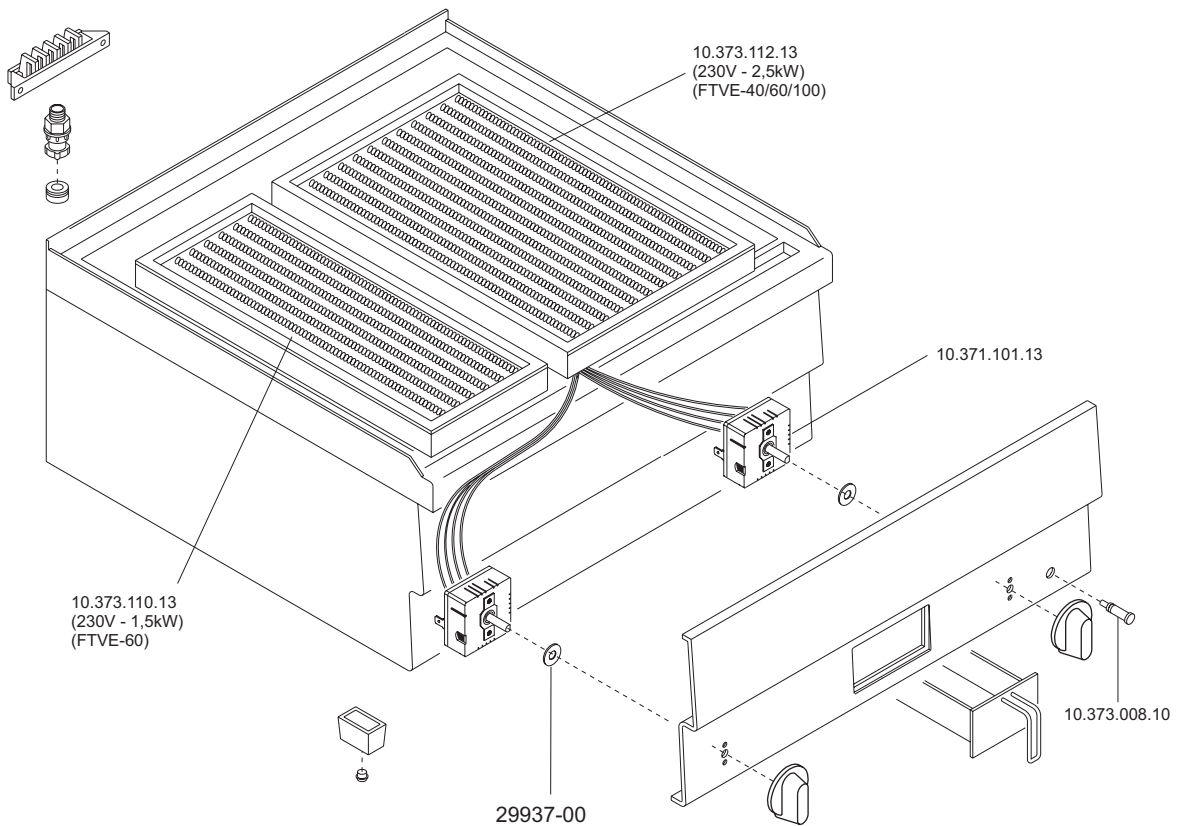

 MARENO INDUSTRIE ALI spa Mareno di Piave (TV)	ELABORATO:	APPROVATO:	GRUPPO:	DENOMINAZIONE:		
	<i>Plinatti</i>		Serie CE 600 (snack)	Impianto elettrico e mobile		
	DATA:	DATA:	PARTICOLARE:	REV. N.	DEL	DISEGNO N.
	10 Gen 97	10 Gen 97	Disegno esploso per ricambi	▼	▼	▼
SOST. DIS.	Z00 - 9701.3.6.47.FTV		Z 0 0 - 9 7 0 1 . 3 . 6 . 4 7 . F T V			

FRY TOP IN VETROCERAMICA ELETTRICI
 CERAN HOBBS FRY TOP ELECTRIC HEATED
 GRILLES ELECTRIQUES AVEC PLAQUE VITROCERAMIQUE
 ELEKTROBEHEIZTE BRAT UND-GRILLPLATTEN MIT CERAN-KOCHFLÄCHEN

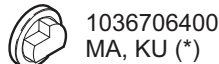
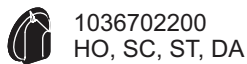
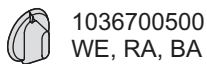
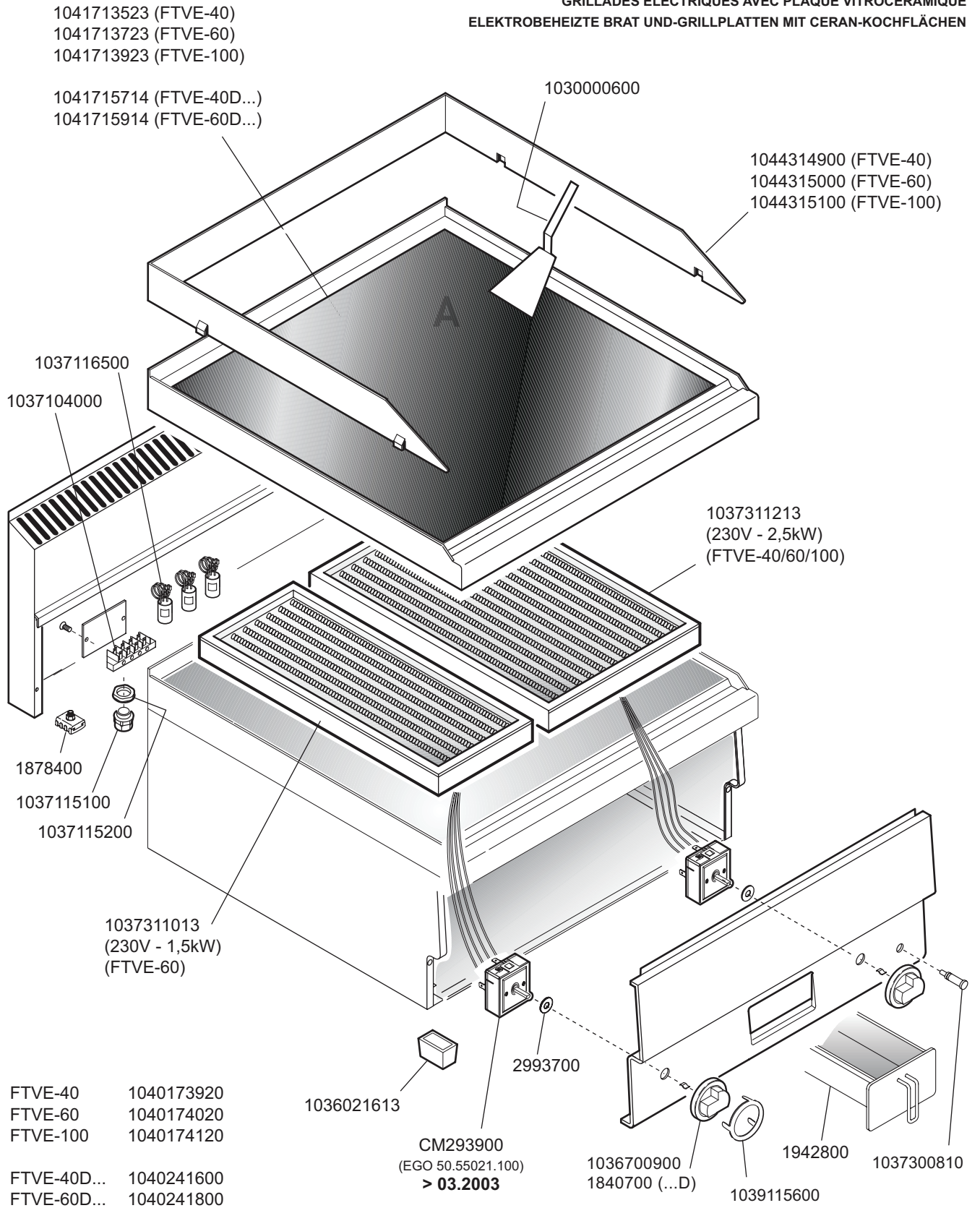

ELABORATO:	APPROVATO:	GRUPPO:	DENOMINAZIONE:		
G.Z.		Serie 600 Snack	Impianto elettrico - Mobile		
DATA:	DATA:	PARTICOLARE:	REV. N.	DEL	DISEGNO N.
10 Gen 1997	10 Gen 1997	Disegno esploso per ricambi	▼	▼	▼
SOST. DIS.	Z01.0104.3.6.47.FTV	CE	Z02	0803	3.6.47