

NP70-10

Mod.

NF74E10 CR0599200

NF76E10 CR0599430

FRIGGITRICI ELETTRICHE 10+10 LITRI  
ELECTRIC HEATED FRYERS 10+10 LITERS  
FRITEUSES ELECTRIQUES 10+10 LITRES  
ELEKTRO FRITEUSEN 10+10 LITERS

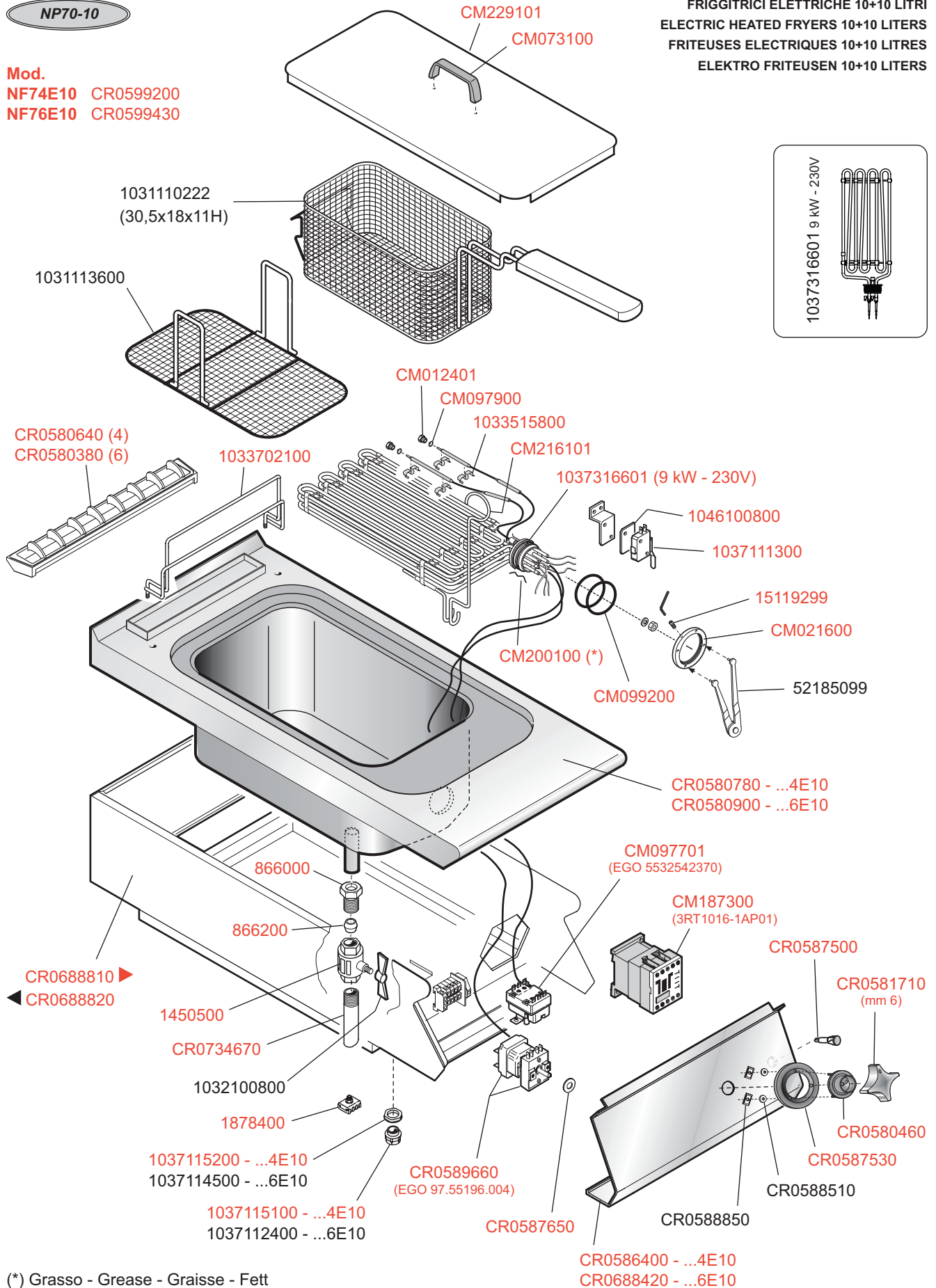

(\*) Grasso - Grease - Graisse - Fett

 <b>MARENO INDUSTRIE ALI spa</b> Mareno di Piave (TV)	ELABORATO:	APPROVATO:	GRUPPO:	DENOMINAZIONE:		
			Serie NP70 (Vasche 10 litri)	Impianto elettrico e mobile		
	DATA:	DATA:	PARTICOLARE:	REV. N.	DEL	DISEGNO N.
	01 Gen 2010	01 Gen 2010	Disegno esploso per ricambi	Z00	0110	3.P7.45
SOST. DIS.						