

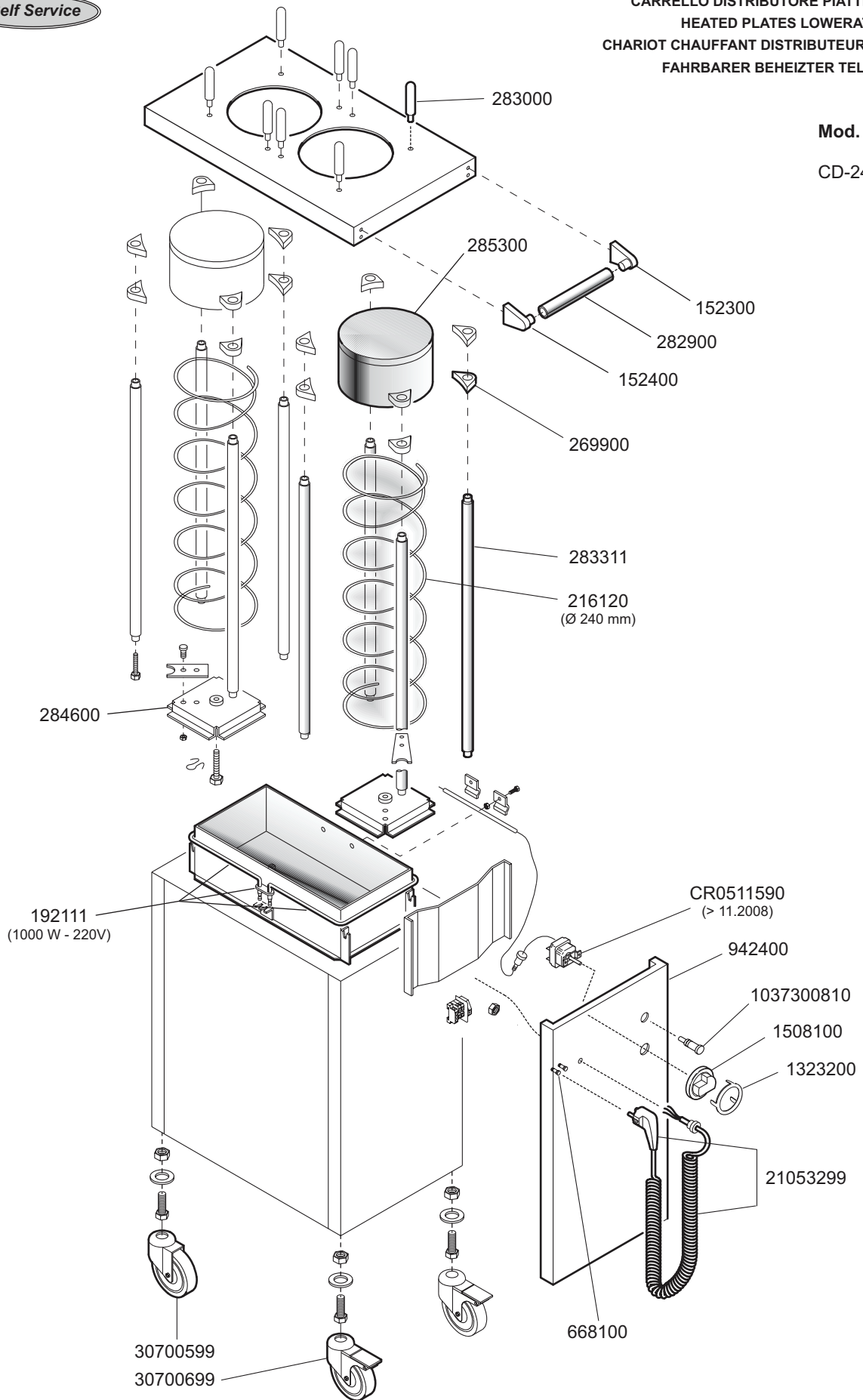

Mod.

CD-24 9550310



 MARENO INDUSTRIE ALI spa Mareno di Piave (TV)	ELABORATO:	APPROVATO:	GRUPPO:	DENOMINAZIONE:		
	LZ		Serie Distribuzione SS	Impianto elettrico e mobile		
	DATA:	DATA:	PARTICOLARE:	REV. N.	DEL	DISEGNO N.
	10 Gen 1996	10 Gen 1996	Disegno esploso per ricambi	▼ Z01	▼ 0509	▼ 4.1.13
SOST. DIS.	P00 9601 4.1.13.C24		