

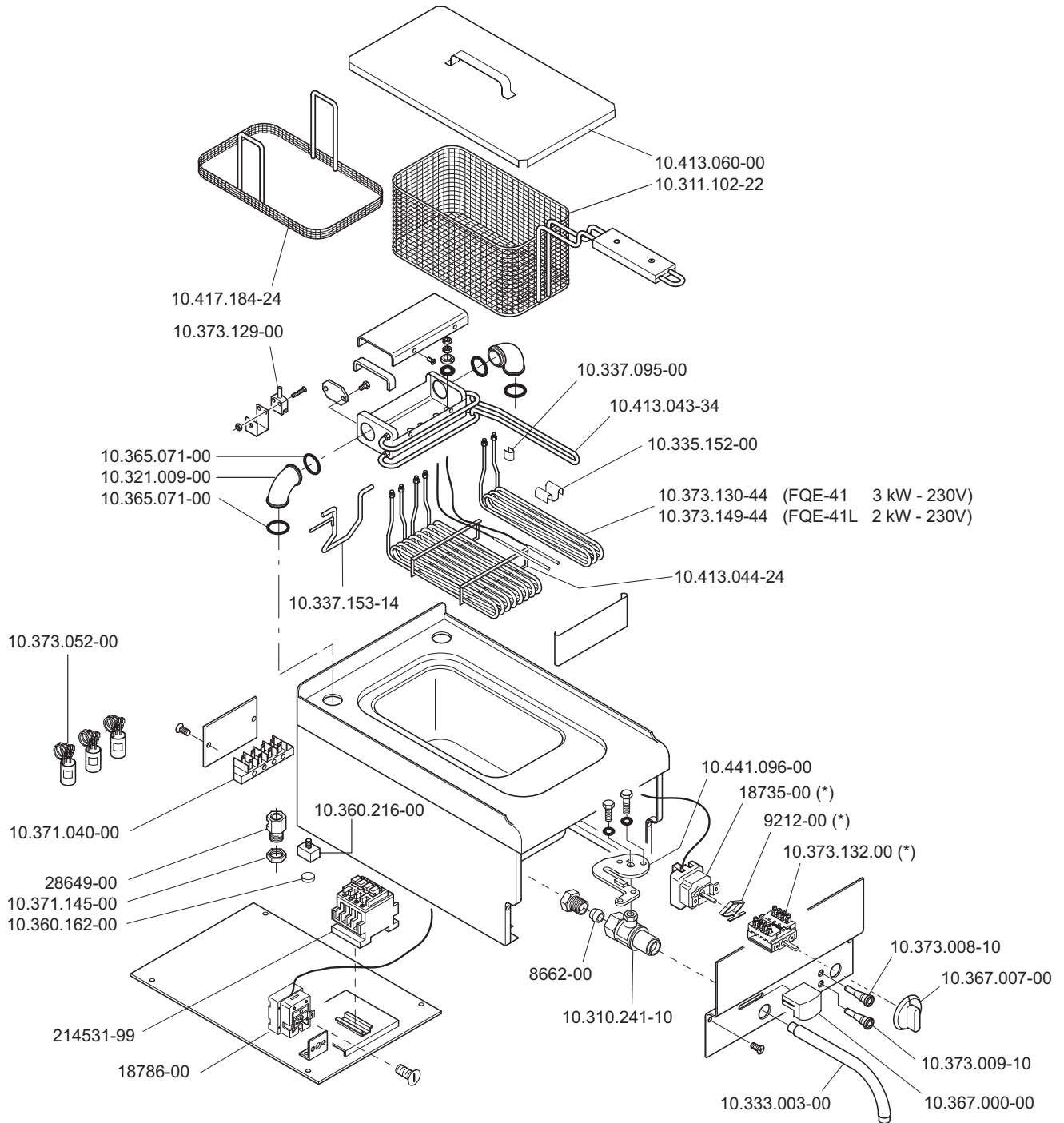

FRIGGITRICE ELETTRICA
 ELECTRIC HEATED FRYER
 FRITEUSE ELECTRIQUE
 ELEKTRO FRITZEUSE
 FREIDORA ELECTRICA

FQE-41 10.401.941-20
 FQE-41L 10.401.943-20
 FQE-41L2 10.402.002-10



(*) 18737-00 = 18735-00 + 9212-00 + 10.373.132.00

 MARENO INDUSTRIE ALI spa Mareno di Piave (TV)	ELABORATO:	APPROVATO:	GRUPPO:	DENOMINAZIONE:		
	<i>Plinetti</i>		Serie CE 600 (Snack)	Impianto elettrico		
	DATA:	DATA:	PARTICOLARE:	REV. N.	DEL	DISEGNO N.
	10 Giu 96	10 Giu 96	Disegno esploso per ricambi	▼	▼	▼
SOST. DIS.	M01 - 9606.3.6.00.F4E		M01 - 9606.3.6.00.F4E			

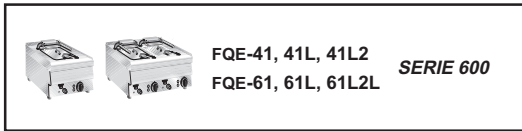

FRIGGITRICE ELETTRICA
ELECTRIC HEATED FRYER
FRITEUSE ELECTRIQUE
ELEKTRO FRITEUSE
FREIDORA ELECTRICA

FQE-41 10.401.941-30
FQE-41L 10.401.943-30
FQE-41L2 10.402.002-20

FQE-61 10.401.942-30
FQE-61L 10.401.944-30
FQE-61L2 10.402.003-20

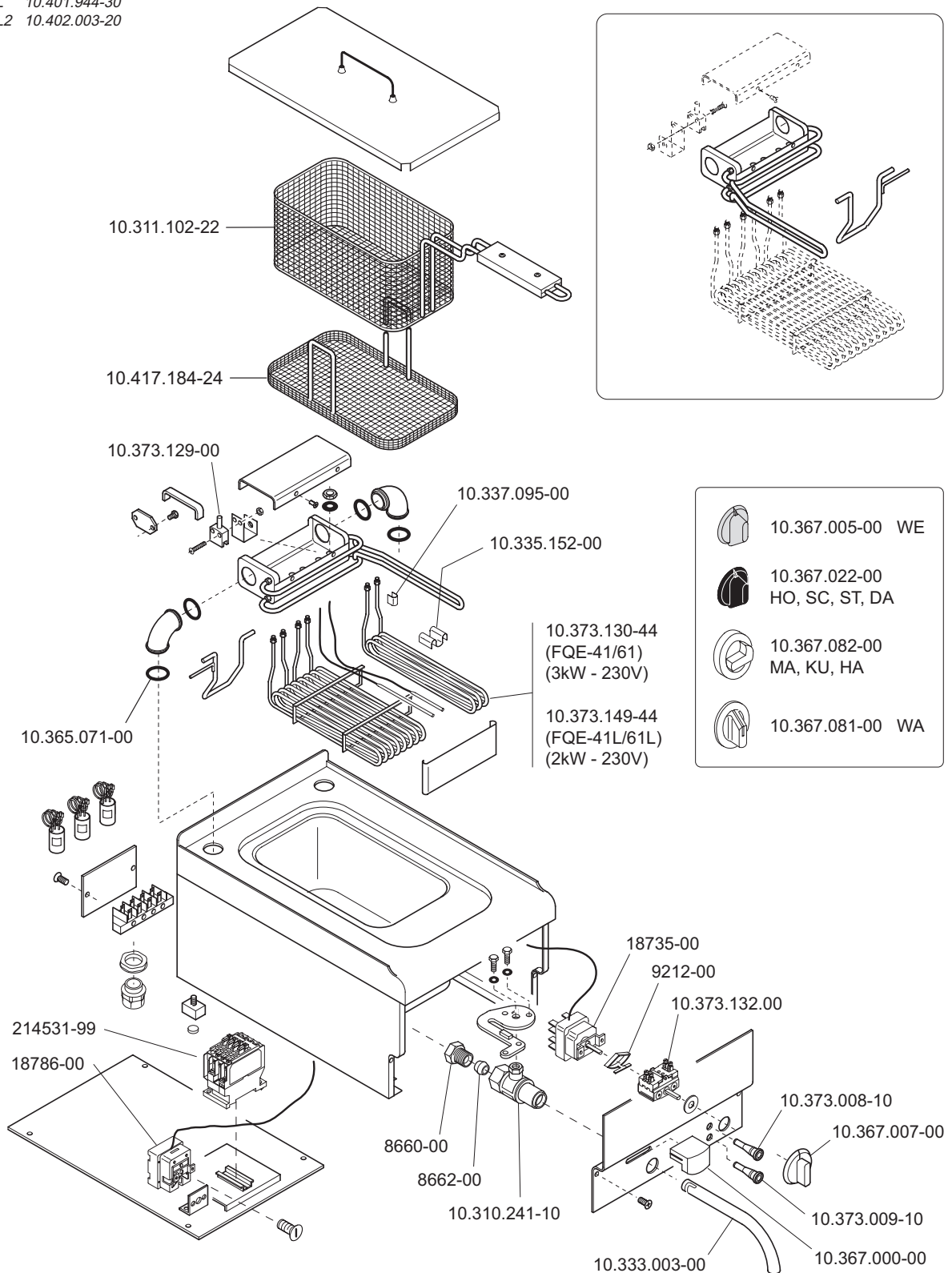

<p>MARENO INDUSTRIE ALI spa Mareno di Piave (TV)</p>	ELABORATO:	APPROVATO:	GRUPPO:	DENOMINAZIONE:		
	<i>Plinetti</i>		Serie CE 600 (snack)	Impianto elettrico e mobile		
	DATA:	DATA:	PARTICOLARE:	REV. N.	DEL	DISEGNO N.
	10 Nov 96	10 Nov 96	Disegno esploso per ricambi	▼	▼	▼
SOST. DIS.	Z00 - 9611.3.6.42.F41		Z00 - 9611.3.6.42.F41			



FQE-41, 41L, 41L2
FQE-61, 61L, 61L2L
SERIE 600



FRIGGITRICE ELETTRICA
ELECTRIC HEATED FRYER
FRITEUSE ELECTRIQUE
ELEKTRO FRITEUSE
FREIDORA ELECTRICA

FQE-41 10.401.941-30
FQE-41L 10.401.943-30
FQE-41L2 10.402.002-20

FQE-61 10.401.942-30
FQE-61L 10.401.944-30
FQE-61L2 10.402.003-20

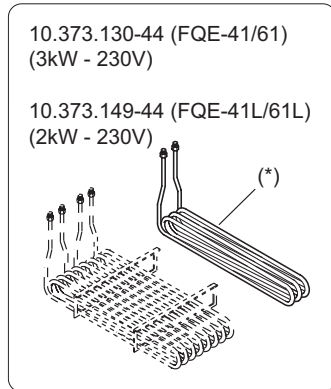

10.373.130-44 (FQE-41/61)
(3kW - 230V)

10.373.149-44 (FQE-41L/61L)
(2kW - 230V)

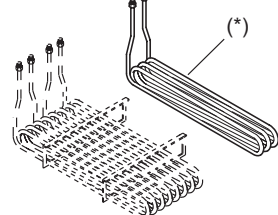

Fino a - Jusqu'à - Bis - Up to
04-1998

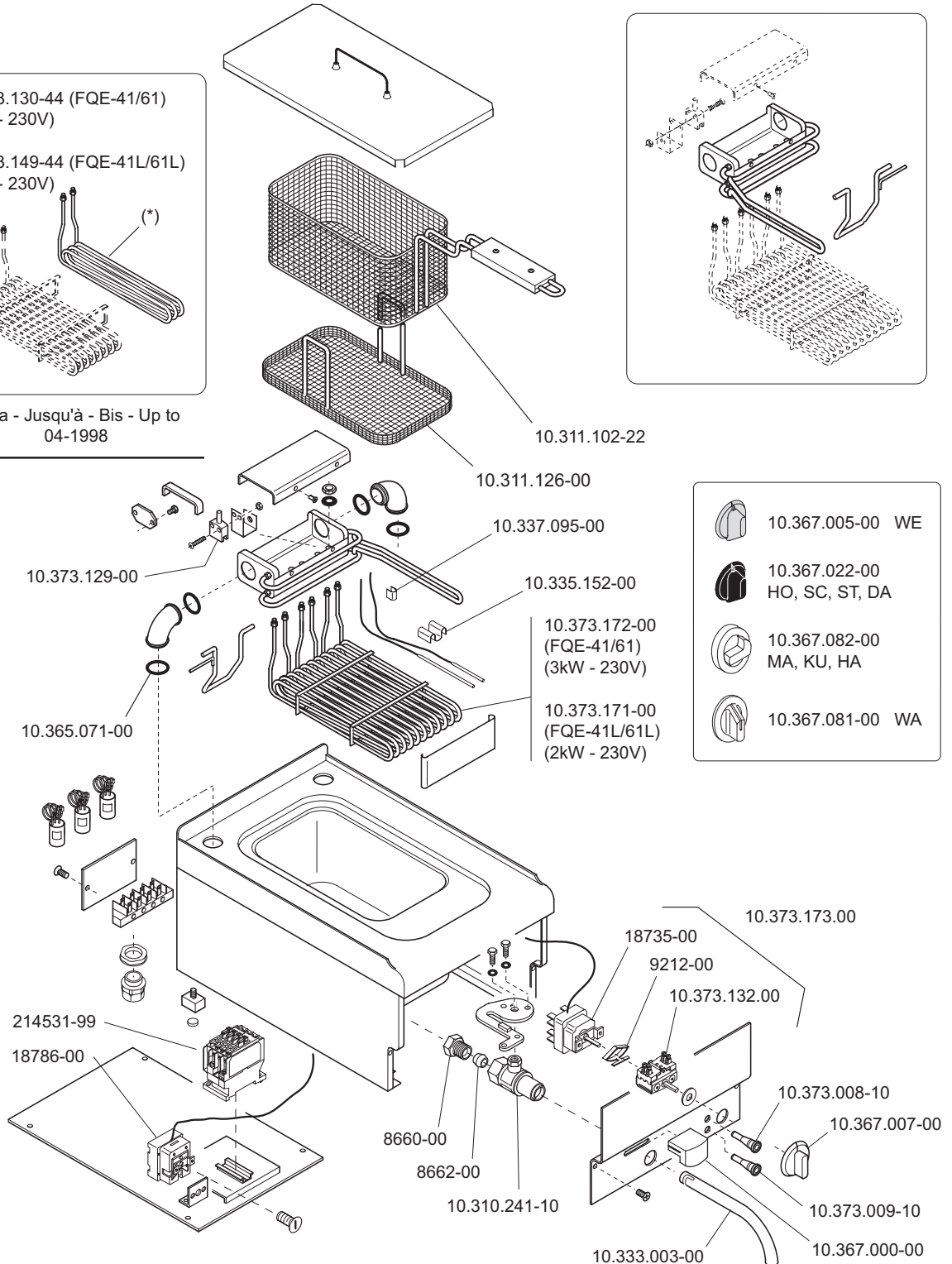
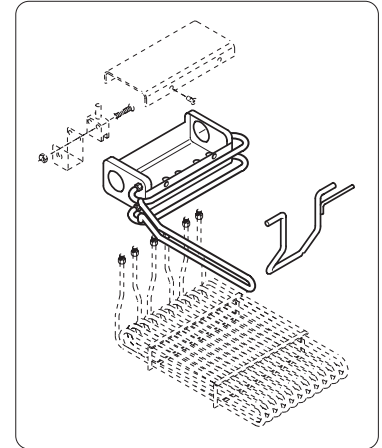

- 10.367.005-00 WE
- 10.367.022-00 HO, SC, ST, DA
- 10.367.082-00 MA, KU, HA
- 10.367.081-00 WA

<p>MARENO INDUSTRIE ALI spa Mareno di Piave (TV)</p>	ELABORATO:	APPROVATO:	GRUPPO:	DENOMINAZIONE:		
	<i>Platt</i>		Serie CE 600 (snack)	Impianto elettrico e mobile		
	DATA:	DATA:	PARTICOLARE:	REV. N.	DEL	DISEGNO N.
	19 Nov 98	19 Nov 98	Disegno esploso per ricambi	▼	▼	▼
SOST. DIS.	Z00 - 9611.3.6.42.F41		Z 0 1 - 9 8 1 1 . 3 . 6 . 4 2 . F 4 1			

OFQE-41, FQE 41 1040194130
 FQE 41L 1040194330
 FQE 41L2 1040200220

OFQE-61, FQE 61 1040194230
 FQE 61L 1040194430
 FQE 61L2 1040200320

FRIGGITRICI ELETTRICHE
 ELECTRIC HEATED FRYERS
 FRITEUSES ELECTRIQUES
 ELEKTROBEHEIZTE FRITUSEN

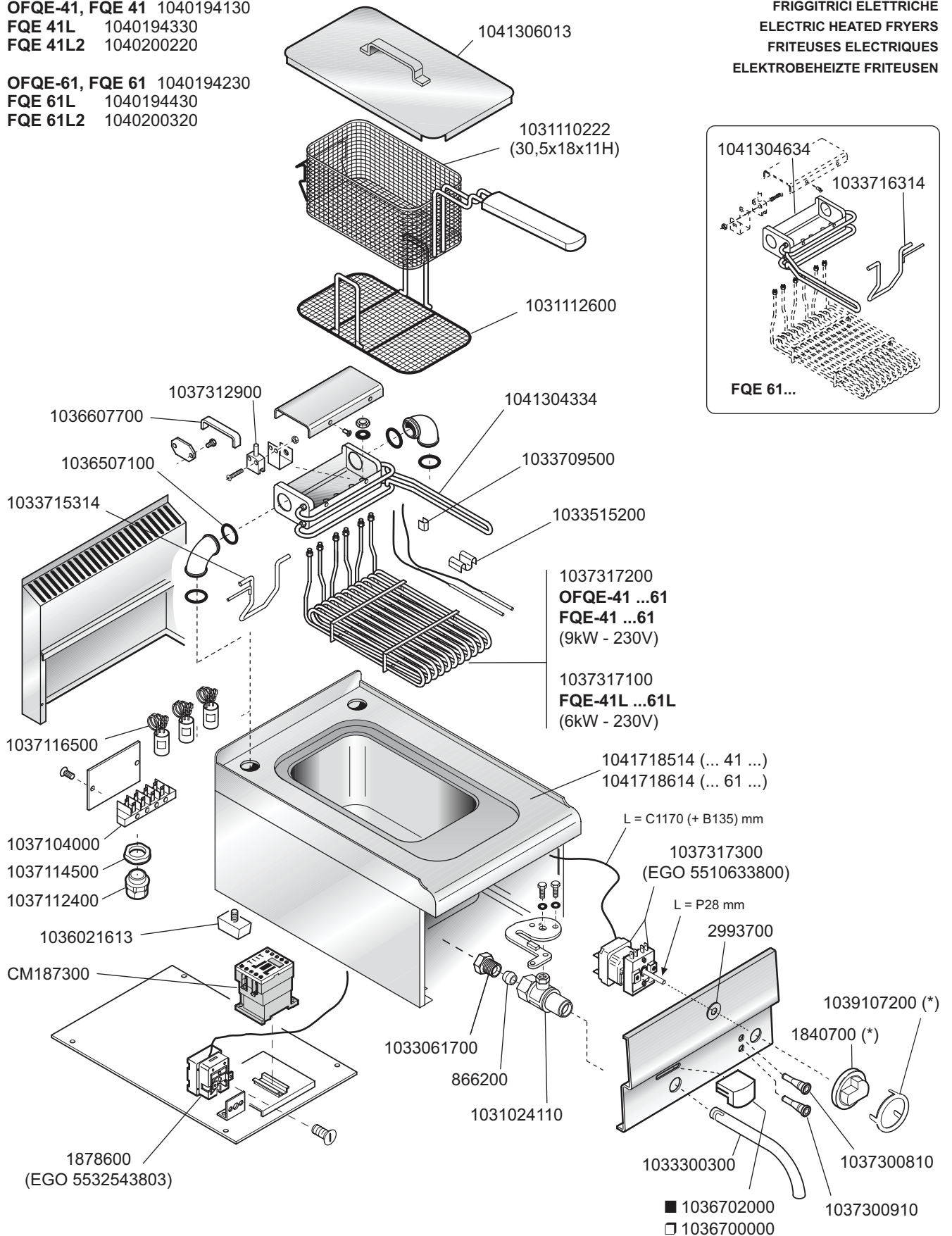

CR0502150 (Metos) 1036700500 WE 1036702200 HO, SC, ST, DA 1036708200 MA (*) ■ Nero - Black - Schwarz - Noir
 CR0502150 (Bartscher) 1036700500 WE 1036702200 HO, SC, ST, DA 1036708200 MA (*) □ Verde - Green - Grün - Vert
 CM188600 (Franke)

 MARENO INDUSTRIE ALI spa Mareno di Piave (TV)	ELABORATO:	APPROVATO:	GRUPPO:	DENOMINAZIONE:		
	G.Z.		Serie 600 Snack	Impianto elettrico - Mobile		
	DATA:	DATA:	PARTICOLARE:	REV. N.	DEL	DISEGNO N.
	05 Dic 2000	05 Dic 2000	Disegno esploso per ricambi	▼ Z02	▼ 0106	▼ 3.6.42.FQE
SOST. DIS.	Z01.9811.3.6.42.F41		CE			

OFQE-41, FQE 41 1040194130
FQE 41L 1040194330
FQE 41L2 1040200220

OFQE-61, FQE 61 1040194240
FQE 61L 1040194440
FQE 61L2 1040200330

FRIGGITRICI ELETTRICHE
ELECTRIC HEATED FRYERS
FRITEUSES ELECTRIQUES
ELEKTROBEHEIZTE FRITZESEN

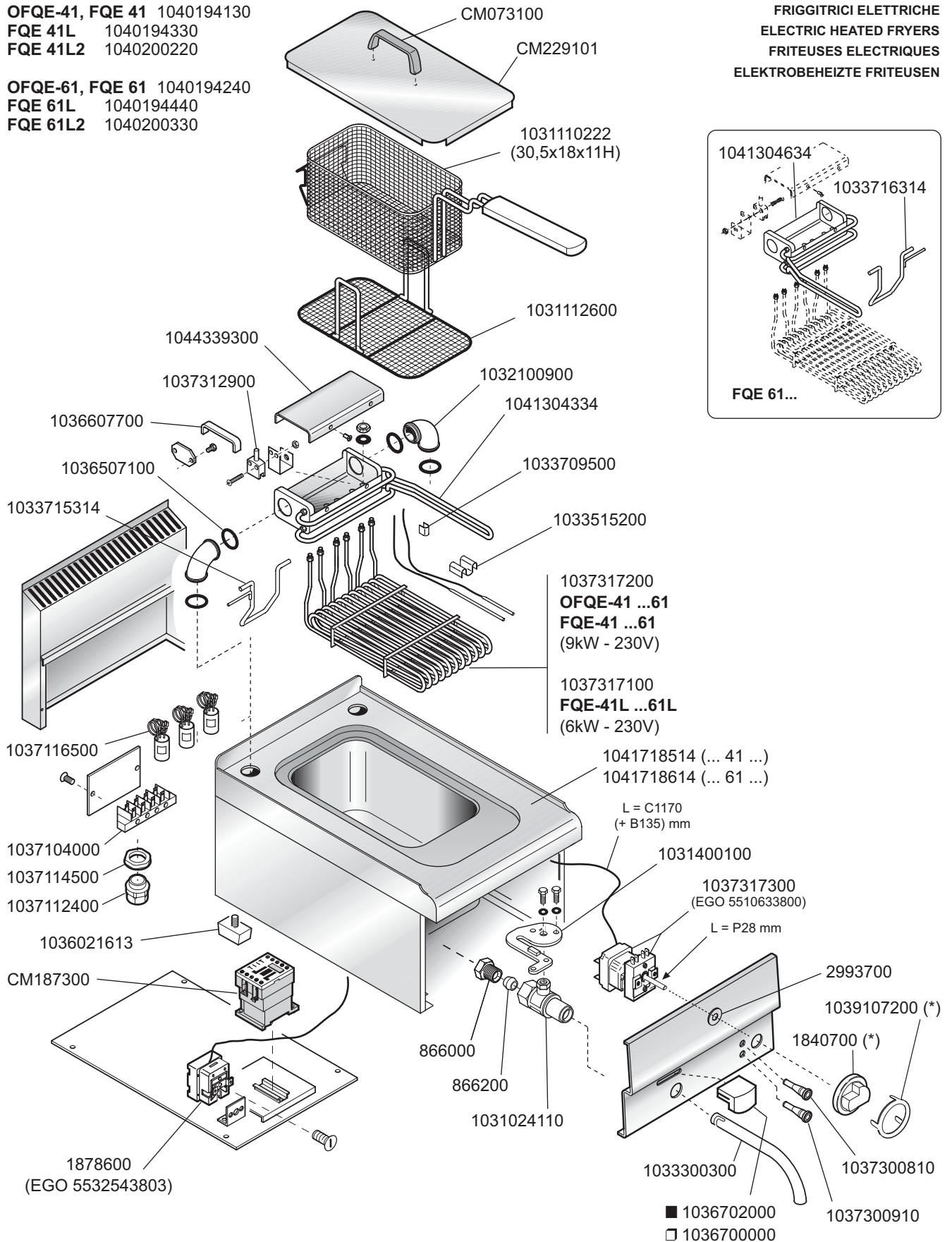

CR0502150 (Metos)
 CR0502150 (Bartscher)
 CM188600 (Franke)
 1036700500 WE
 1036702200 HO, SC, ST, DA
 1036708200 MA (*)
 ■ Nero - Black - Schwarz - Noir
 □ Verde - Green - Grün - Vert

 MARENO INDUSTRIE ALI spa Mareno di Piave (TV)	ELABORATO:	APPROVATO:	GRUPPO:	DENOMINAZIONE:		
			Serie 600 Snack	Impianto elettrico - Mobile		
	DATA:	DATA:	PARTICOLARE:	REV. N.	DEL	DISEGNO N.
	05 Dic 2000	05 Dic 2000	Disegno esploso per ricambi	▼ Z02	▼ 0106	▼ 3.6.42.FQE
SOST. DIS.	Z01.9811.3.6.42.F41					