

FRIGGITRICI ELETTRICHE
ELECTRIC HEATED FRYERS
FRITEUSES ELECTRIQUES
ELEKTRO FRITEUSEN
FREIDORAS ELECTRICAS

FQE-40 (KB) 10.401.643-10
FQE-60 (KB) 10.401.644-10

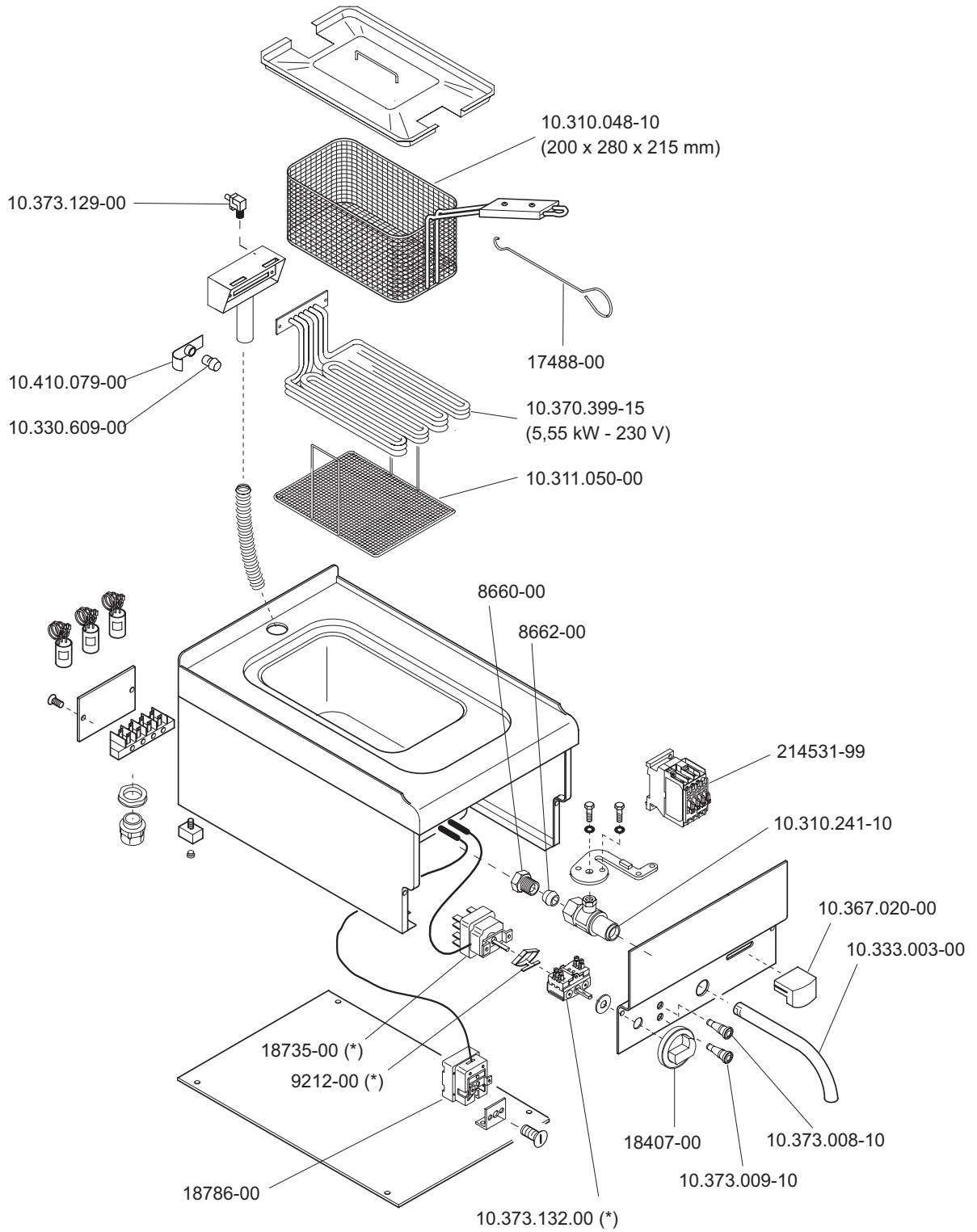

ELABORATO:	APPROVATO:	GRUPPO:	DENOMINAZIONE:		
<i>Plimatti</i>		Serie CE 600 (snack)	Impianto elettrico e mobile		
DATA:	DATA:	PARTICOLARE:	REV. N.	DEL	DISEGNO N.
10 Nov 96	10 Nov 96	Disegno esploso per ricambi	▼	▼	▼
SOST. DIS.	Z00 - 9611.3.6.40.F40		Z00 - 9611.3.6.40.F40		

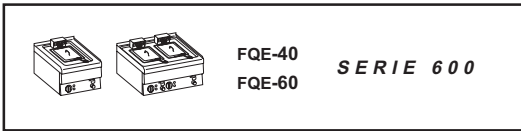

FRIGGITRICI ELETTRICHE
ELECTRIC HEATED FRYERS
FRITEUSES ELECTRIQUES
ELEKTRO FRITEUSEN
FREIDORAS ELECTRICAS

FQE-40 (KB) 10.401.643-10
FQE-60 (KB) 10.401.644-10

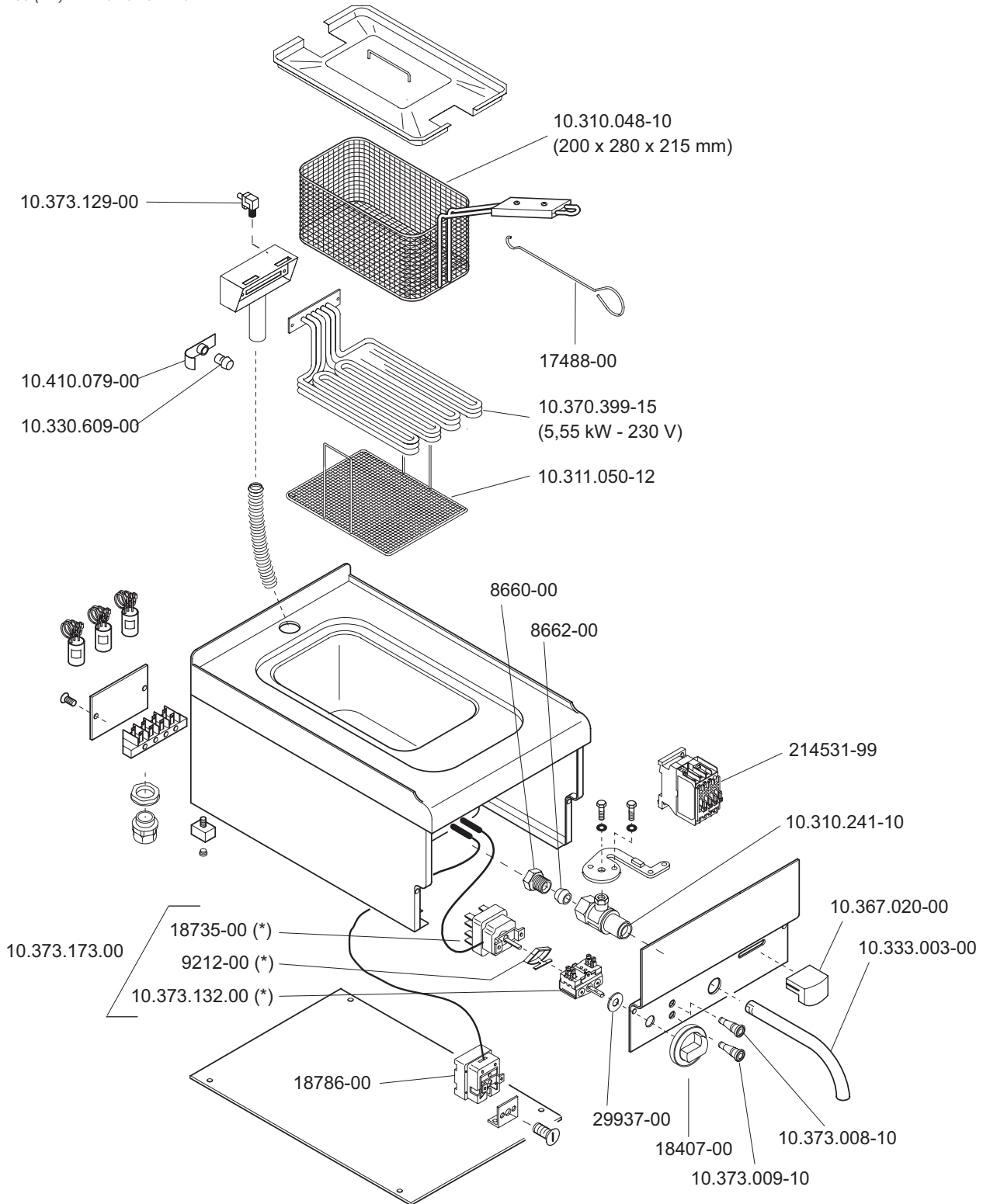

 MARENO INDUSTRIE ALI spa Mareno di Piave (TV)	ELABORATO:	APPROVATO:	GRUPPO:	DENOMINAZIONE:		
	<i>Platt</i>		Serie CE 600 (snack)	Impianto elettrico e mobile		
	DATA:	DATA:	PARTICOLARE:	REV. N.	DEL	DISEGNO N.
	10 Nov 98	10 Nov 98	Disegno esploso per ricambi	▼	▼	▼
SOST. DIS.	Z00 - 9611.3.6.40.F40		Z 0 1 - 9 8 1 1 . 3 . 6 . 4 0 . F 4 0			

FQE 40 1040164310 (KB)
 FQE 40D 1040172330
 FQE 40DSP 1040172530 (B)

FQE 60 1040164410 (KB)
 FQE 60D 1040172430
 FQE 60DSP 1040172630 (B)

FRIGGITRICI ELETTRICHE
 ELECTRIC HEATED FRYERS
 FRITEUSES ELECTRIQUES
 ELEKTROBEHEIZTE FRITUSEN

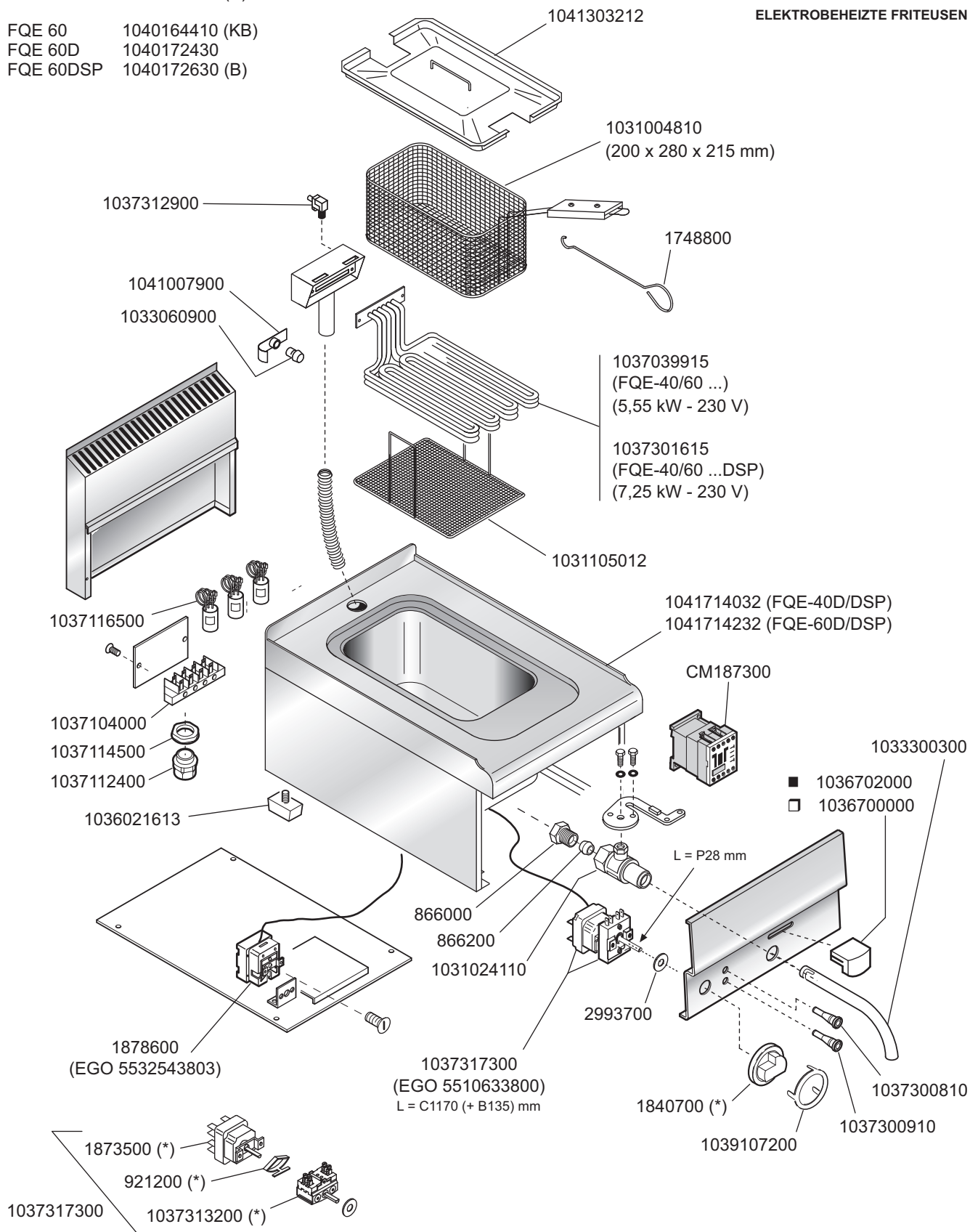

1036700500 WE 1036702200 HO, SC, ST, DA 1036708200 MA (*) ■ Nero - Black - Schwarz - Noir □ Verde - Green - Grün - Vert

 MARENO INDUSTRIE ALI spa Mareno di Piave (TV)	ELABORATO:	APPROVATO:	GRUPPO:	DENOMINAZIONE:		
	G.Z.		Serie 600 Snack	Impianto elettrico - Mobile		
	DATA:	DATA:	PARTICOLARE:	REV. N.	DEL	DISEGNO N.
	05 Dic 2000	05 Dic 2000	Disegno esploso per ricambi	Z01	0102	3.6.40.F40
SOST. DIS.	Z01.9811.3.6.40.F40					