

APPENDIX 5: EXPLODED VIEW OF 60 SILVER MIXER AND PARTS LIST

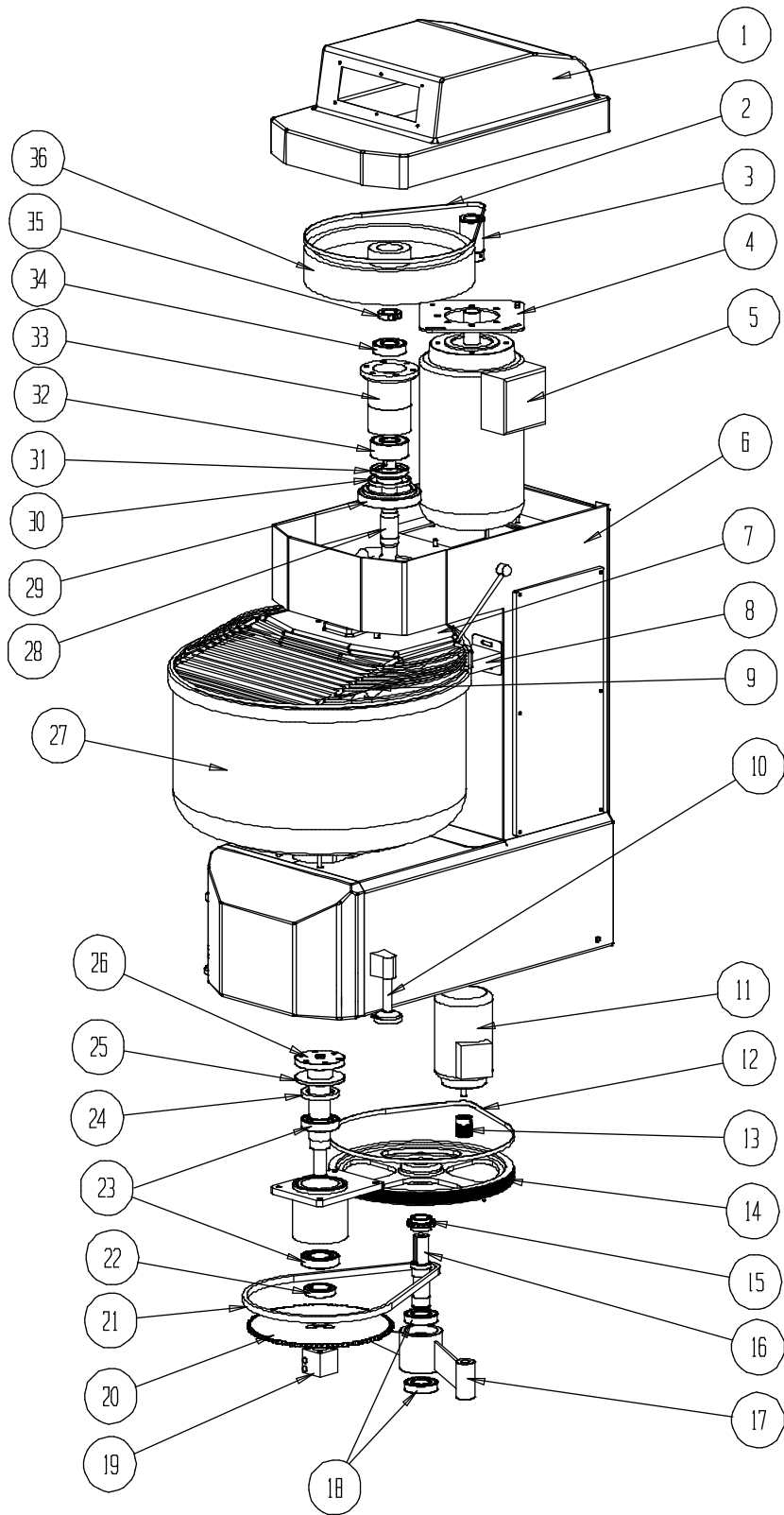

Pos.	Description	Qty	Part no.
01	Head cover	1	125044
02	Belt for spiral tool motor 50 Hz (XPZ 1512)	5	C00150
03	Pulley for spiral tool motor 50Hz	1	183025
04	Sliding plate for spiral tool motor	1	191000
05	Spiral tool motor 400/415V 50 Hz	1	E00170
06	Mixer body	1	285049
07	Fixed bowl cover in ABS plastic	1	205044
08	Thrust block for bowl	2	113019
09	Mobile bowl cover - stainless steel grid	1	202092
09	Mobile bowl cover – ABS plastic	1	202073
10	Foot	2	C00979
11	Bowl motor 400/415V 50 Hz	1	E00204
12	Belt for bowl motor (type: poly-v j 11)	1	C00943
13	Pulley for bowl motor 50 Hz	1	183065
14	Pulley for bowl transmission	1	180043
15	Pinion for bowl transmission	1	157007
16	Shaft for bowl transmission	1	100053
17	Support for bowl transmission	1	213001
18	Bearing for bowl transmission (type: 6208 2RS)	2	C00902
19	Support for plate wheel	1	163016
20	Gear for bowl	1	157005
21	Chain ½” x 5/8”	1	C00941
22	Lock nut	1	107001
23	Bearing for bowl (type: 32210)	2	C00966
24	Sealing ring (type: MIM)	1	C00092
25	Protection plate	1	142010
26	Shaft for bowl	1	100052
27	Bowl	1	261045
28	Spiral tool	1	220016
29	Fastening support ring	1	104012
30	Protection plate	1	142008
31	Sealing ring (type: MIM)	1	C01000
32	Lower bearing for spiral tool (type: 3308)	1	C00964
33	Spiral tool hub	1	163013
34	Upper bearing for spiral tool (type: 6307 2RS)	1	C01066
35	Lock nut	1	107000
36	Pulley for spiral tool 50Hz.	1	180039

N.B.

- (i) Technical data is not binding. The data can be changed in order to improve the product.
(ii) Drawings and illustrations are only indicative.