



Via Artigianato 85 – 25030 Torbole Casaglia.  
(BRESCIA) – ITALY – Tel 030 265 04 79 –Fax 030 265 01 43

USE AND MAINTENANCE INSTRUCTION MANUAL  
**PLANETARY MIXER *BM40***  
*MECHANICAL SPEED VARIATION*



# USE AND MAINTENANCE INSTRUCTION MANUAL MECHANICAL SPEED VARIATION PLANETARY MIXER BM40

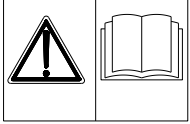

This instruction, use and maintenance manual provides the instructions necessary for transportation, starting-up, use and maintenance of the mixer. It must be consulted before any one of these acts.

The manual must be read not only by maintenance technicians, but also by operators in charge of the mixer who must correctly carry out what is within their line of competence.

The manual is an integral part of the mixer. It must be kept in a suitable place where it can remain intact and where it can be consulted during the whole life of the machine.

## INDEX

SAFETY INSTRUCTIONS .....	3
RESIDUAL RISKS .....	3
RESIDUAL RISKS, PROHIBITIONS, OBLIGATIONS: Summarised table .....	4
SYMBOLS USED AND QUALIFICATIONS OF THE PERSONNEL .....	5
USE AND DESCRIPTION OF THE MIXER .....	5
INSTRUCTIONS FOR USE .....	6
IDENTIFICATION, POSITION OF THE OPERATOR AND DANGEROUS AREAS .....	8
TECHNICAL DATA, PACKAGING, DIMENSIONS AND WEIGHT .....	9
TRANSPORTATION AND HANDLING .....	9
STORAGE .....	10
INSTALLATION .....	10
PRESERVATION OF THE MIXER .....	10
WARRANTY TERMS .....	10
CLEANING AND MAINTENANCE OPERATIONS .....	11
ROUTINE MAINTENANCE .....	12
EXTRAORDINARY MAINTENANCE .....	12
PERIODICAL MAINTENANCE .....	13
SPARE PARTS .....	13
MAIN COMPONENTS .....	13
DISMANTLING AND WASTE DISPOSAL .....	13
SPARE PARTS LIST .....	14
BLOCKAGE OF MACHINERY AND NECESSARY REMEDIES .....	16
ELECTRICAL LAYOUT .....	16

## SAFETY INSTRUCTIONS.

The safe and systematic use of the mixer is subordinated to compliance with behaviour and standards listed hereafter.

### Safety standards

- Personnel must be in good physical and mental conditions and be adequately instructed on the use of the mixer having read this publication.
- The safety manager of the company, of the operating area and of the department, when choosing the person who must use this equipment (a person suitable for the job according to Standards in force), must consider his/her cultural preparation, physical suitability and the psychological aspect (mental stability, sense of responsibility, etc.). Moreover, based on the attitudes and capacity that were verified, the manager must provide this person with proper training, having him/her read the present publication, in order to have full knowledge of the mixer and of the rules of behaviour applying to it.
- The area around the mixer must be well lit, free from other objects and clean.
- The personnel in charge of running, cleaning and carrying out maintenance on the mixer must wear the required PPE (personal protective equipment).
- Do not wear dangling clothing or fluttering hems (ties, napkins, torn suits, open jackets etc.) to avoid getting entangled.
- During maintenance and cleaning, the operator must disarm the master switch and place the system in safe conditions (for example, removing the plug).
- Never leave the mixer unattended while it is running. Be careful of abnormal noises or behaviour. Keep away from rotating parts. Never open the grid before the equipment has come to a complete stop.
- At the end of work, empty the machine completely, disconnect the master switch cutting the power, place it in safe conditions and clean it with a neutral degreasing agent (i.e. with Marseille soap).

### Safety devices.

- The mixer is equipped with some devices which protect its operation as well as the safety of the operator. They must not be removed or modified. Their functioning must be checked periodically.
- Master switch: cuts power from the mixer, for maintenance in safe conditions.
- Circuit breaker switch: cuts power if the electric motor overheats.
- Fixed guards: All casings and guards fixed with screws or mechanical locks can be removed only for maintenance, by specialised personnel and in the prescribed modalities. When the work is over, they must be mounted immediately.
- Mobile guards: Movement of the grid activates a micro switch which prevents the mixer from running if the grid is open. If the grid is lifted while the mixer is running, it stops the cycle unconditionally, just like an emergency stop. The start button must be pressed for the mixer to restart.

### Safety Standards applied to the mixer.

- EN 292 Safety of machinery.
- EN 294 Minimum distances to prevent accidental contact.
- CEI 17-13. Low-voltage switchgear and control gear assemblies.
- Community Directives: 89/392/EEC, 89/336/EEC, 91/368/EEC, 93/44 EEC, 93/68 EEC.

### RESIDUAL RISKS



Danger for limbs: Going beyond the protective grid or removing the casing during maintenance, it is possible to access the moving organs of the mixer.



They are dangerous areas where serious physical injuries can occur. Do not introduce limbs or other objects without having placed the mixer in safe conditions.



Danger of electrocution: the mixer must not operate without an adequate earthing system. It must be connected to a system built in compliance with construction standards in force in the country where it is installed.



Automatic cycle: after starting up the mixer, it follows an automatic operating cycle. Never go past the safety barriers with your limbs or other objects while it is running.

RESIDUAL RISKS, PROHIBITIONS, OBLIGATIONS: Summarised table.

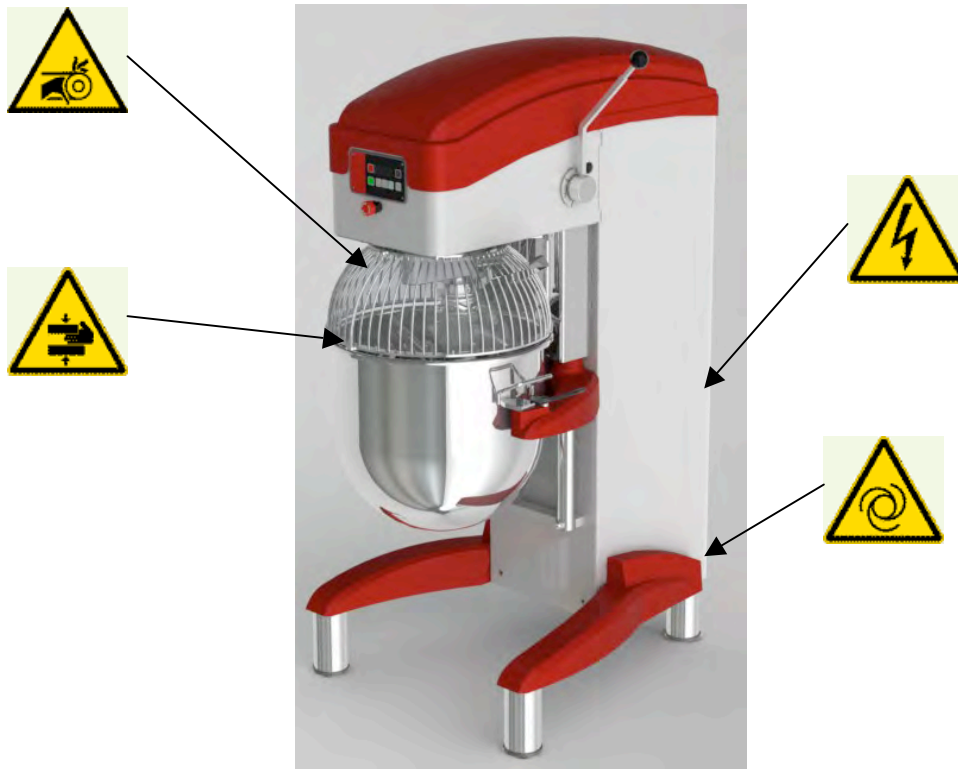

Obligation to disconnect mixer before working on it.



Obligation to carry out earthing.

Stability for machinery: if there is the possibility of slipping on wet or greasy surfaces or positioning the equipment in unstable places (ships, planes or other), use the appropriate attachments for stable fixing (4 anchoring devices with 200 kg resistance, M8 screws)







**ATTENTION!**

- Where the required PPE during operations.
- Clean the mixer thoroughly after use.
- Do not remove the safety devices or protective casings.
- Do not introduce any object through the protective grid with organs in movement: danger of objects being thrown.
- Before carrying out any manoeuvre beyond the protective grid, wait for the mixer to come to a complete stop.

**SYMBOLS USED AND QUALIFICATIONS OF THE PERSONNEL.**

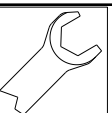
The following indicates the qualifications of personnel required to operate the mixer.

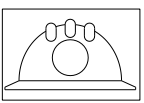
The symbols placed on a chapter mean to recall the specific skill needed for the intervention described therein. Wherever no symbols are present, the chapter applies to everyone.

Symbol	Description	Features
	OPERATOR	Person acquainted with operating, adjusting and programming the mixer and its protection and safety systems, who knows possible work cycles and ingredients to be used with relative maximum admitted amounts and who has read and understood the use and maintenance manual.
	ELECTRICAL MAINTENANCE TECHNICIAN	Person in good health who due to qualification, job or experience is qualified to carry out the profession of electrical maintenance technician and who has read and understood the use and maintenance manual.
	MECHANICAL MAINTENANCE TECHNICIAN	Person in good health who due to qualification, job or experience is qualified to carry out the profession of mechanical maintenance technician and who has read and understood the use and maintenance manual.
	PERSON IN CHARGE OF HANDLING ZIONE	Person in good health who due to qualification, job or experience is qualified to carry out handling of loads and who has read and understood the use and maintenance manual.
	ASSISTANCE Tel. +39 030.2650488 Fax +39 030.2650143	<ul style="list-style-type: none"> <li>▪ <b>Requesting manual updates.</b></li> <li>▪ Phone customer assistance concerning functioning, starting or faults of machinery.</li> <li>▪ Requesting spare parts, repairs, system overhauls, interventions on site.</li> <li>▪ Training courses</li> </ul>
	ATTENTION.	This sign requests you to pay particular attention to the operations indicated. Lack of compliance can cause harm to personnel or damage to the mixer.

#### USE AND DESCRIPTION OF THE MIXER:

BMX40 planetary mixers are highly professional machines, capable of excellent performance. Driven by a high-power motor they use a belt speed variator with a high transmission ratio that is capable of a great excursion between low and high speed and a proportional speed of the instrument.

The change of speed allows you to perfectly whip, beat, mix, amalgamate and air out ingredients ensuring excellent results of the finished product.

The cemented, hardened and rectified gears and the wide size of the belt allow use of the high power installed. Together with the steel structure, they make the mixer sturdy and reliable.

The bowl-lowering device, easy disassembly and the tools supply the mixer with great professionalism.

The accessories provided with the machine have been built with the utmost care: whisk, blade and spiral, together with the shape of the bowl ensure the best mixing results.

The safety devices and electrical control equipment complying with European Standards complete the machinery.

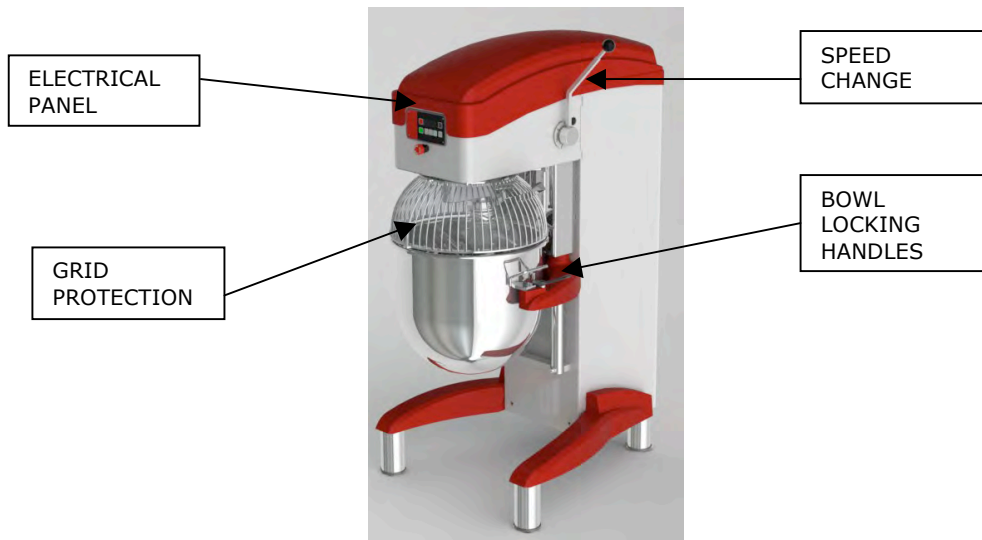

## INSTRUCTIONS FOR USE

To be able to work; the bowl must be mounted and the bowl protective grid closed. Otherwise it will be blocked by the safety systems.

**DO NOT REMOVE OR TAMPER WITH THE ELECTRICAL OR MECHANICAL GUARDS OR SAFETY DEVICES ON THE MACHINE.**

The bowl must be in position BEFORE the tools. It must be inserted with the bowl lever down, putting the bowl plate, placed at the back of the bowl, on the bowl lifting arc.



Complete positioning by having the holes on the bowl support plates match with the centring pins. Block the bowl with the handles.



If it was not previously done, rotate the protective grid of the bowl to the open position and, after having chosen the tool, insert it into the tool holder shaft. Once it is inserted, turn the tool clockwise, having the transmission pin enter the work position as indicated in the figure. Lower it and insert the tool lock ring.



Using the arrows  $\uparrow$  and  $\downarrow$ , on the control panel to lift the bowl to the working position and close the protective grid of the bowl. At this point, after inserting the ingredients, start the work cycle.

## Best Mix control Panel

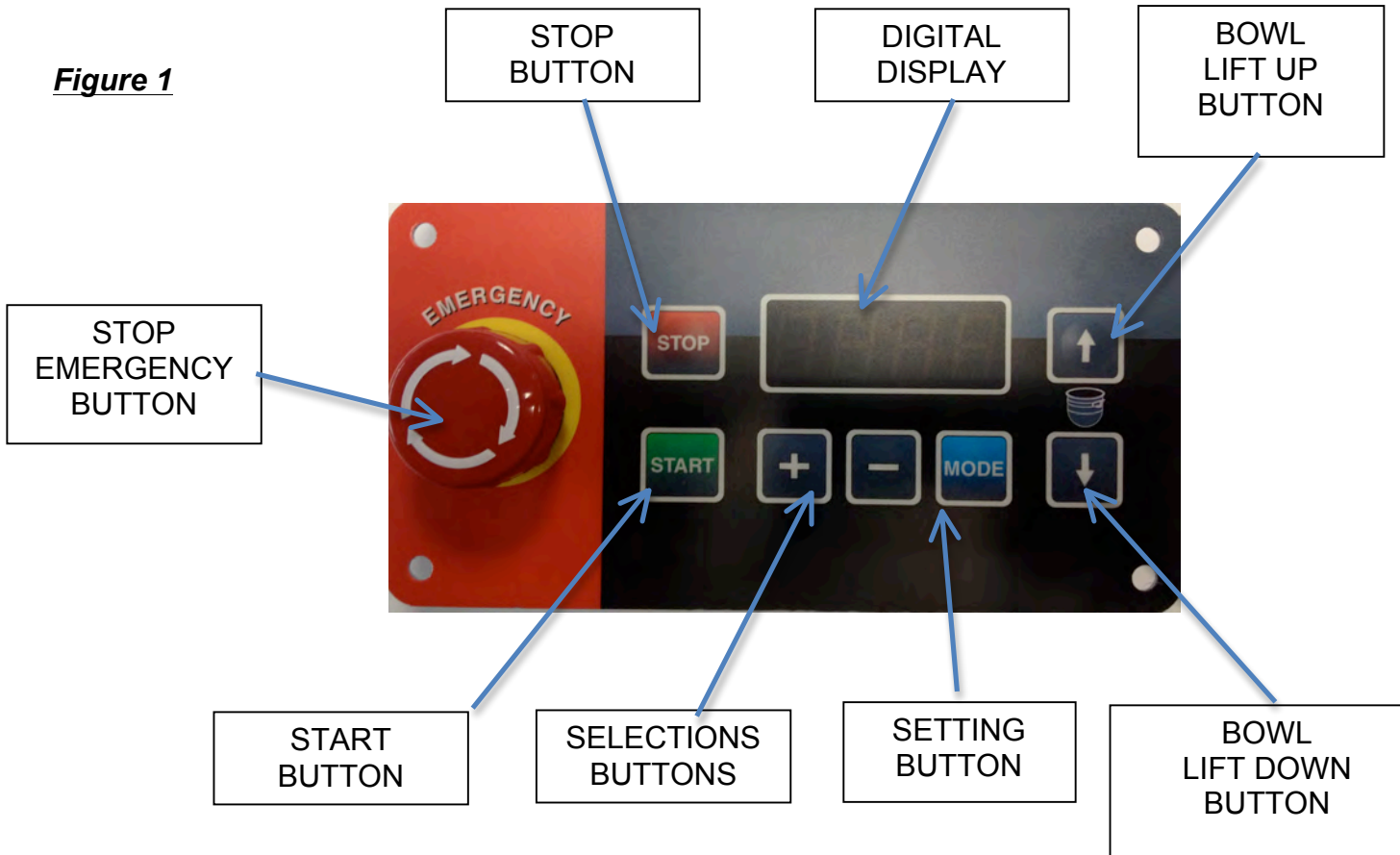

First of all be sure the Emergency stop button is released . The mixer can properly work as Manual or under the Digital timer. If grid and bowl are in the correct position, you will see 4 blue lines in the center of the lcd display. (figure 2a).



**figure 2b**



In event of blue light blinking, double check the grid allignement or final bowl position. If the light are fixed and you would like to operate manually, just press "START". The Mixer will work till you do not press "STOP" or turn the grid from its position.

While the mixer is running as manual , you will see on the digital display, blue lights moving towards right as you can see (figure 2b). Just pressing "Stop" the mixer will immediately stopped it-self and the blue light will come back fixed as "figure 2a".

### WORKING WITH THE DIGITAL TIMER:

If you would like to set the Timer, please press button “MODE” . You should see onto the digital lcd display, the last programmed time as “minutes:seconds” . (figure 3). In case you agree with the timing already set, just press “START” and the mixer will begin to work and the countdown will indicate the resting working time. When time get the 00:00 , the planetary mixer will be automatically stopped.



**Figure3**

### Setting the Timer:

If you need to set a different timing press for some seconds button “MODE”. You should see the “minutes” blinking. Just pressing buttons “+” and “-” is possible to change the mas you prefer. Pressing once again the button “MODE” , you will be able to set “seconds” too. To exit from setting, just press again button “MODE”. The time will stop blinking . Now you are ready to press “start” once again and begin the working cycle.

### **Pay Attention:**

The Best Line Planetary mixers have a meccanichal variable belt drive system with 7 speeds. DO NOT CHANGE SPEEDS IF THE MIXER IS NOT RUNNING. Moving the Speed lever while the mixer is not running, can cause serious problem on the Belt and gears.

While the mixer is running, if you open the protection grid or move the bowl down, i twill be automatically stopped.

Before begin to work with the planetary mixer, please check the speed lever position. To avoid any kind of issues, we suggest to move the lever to the lower speed at every single use. If you are going to use the Dough-Hook and the mixer start spinning at the fastest speed, it might be broken in seconds.



The mixer is provided with a lever to change the tool rotation speed. This mixer has 7 different speeds. ATTENTION: ALWAYS change the speed while the mixer is moving to allow the variable pulley belt to position correctly.



In order to remove the mixture, wait until the tool has stopped. Then turn the protection grid. Use the arrow ↓ into the control panel to lower the bowl and release the tool from the attachment sleeve. Remove the tool and release the bowl from the handles.



The work load of the planetary mixers is established by the customer. Very many problems arise from improper use. If recommended amounts are exceeded, the quality of the product will suffer, as well as the duration of the mechanical organs of the mixer. See the following table for indications on maximum amounts:

APPLICATION	INGREDIENTS	BMX 10	BMX 20	BMX 30	BMX 40	BMX 60	TYPE OF TOOL	POSIT LEVER
Mix with 55% water	Flour+Wat. Kg	3	6	9	12	18	Dough-hook	1
Pasta for croissants	Flour Kg.	2,5	5	7	9	15	Dough-hook	1
Pasta for profiteroles	Flour Kg.	2	4	6	8	12	Dough-hook	1
Meat	Kg.	5	10	15	20	30	Dough-hook /butter biter	1-2
Purée	Potatoes Kg.	5	10	15	20	30	butter biter /whisk	1-2
Egg white	Number of eggs	16	32	50	70	96	Whisk	1-4
Biscuits	Number of eggs	15	30	45	60	90	Whisk	1-3
Meringues	Sugar Kg.	0,75	1,5	2,25	3	4,5	Whisk	1-4
Whipped cream	Litres of cream	2	4	5,5	7	10	Whisk	1-4

#### CONDITIONS FOR USE:

**Atmospheric conditions:** The mixer needs to be installed inside of a lit, ventilated building, on top of a solid and level support. Temperatures from 5 to 40°C with humidity no greater than 90%.

**Lighting:** the light at disposal of the operator must comply with the type of work carried out, in relation to general lighting, according to the Standards in force. It must on any account be sufficient to read the controls and danger signs and must not blind the operator.

- Vibrations: in correct working conditions, vibrations do not create dangerous situations.
- Noise emissions: 70 dbA for normal use.
- Electromagnetic environment: the machine has been built to work correctly in an industrial type of electromagnetic environment.



Environments with risk of explosion: An atmosphere capable of being transformed into an explosive atmosphere due to room and/or operating conditions is defined as a potentially explosive atmosphere.

The mixer was not built to work in environments with potentially explosive atmospheres.

#### IDENTIFICATION, POSITION OF THE OPERATOR AND DANGEROUS AREAS.

There is a plate on the back of the mixer like the one shown which carries indications concerning the manufacturer, the type of machine, serial number, electrical features, frequency, absorbed power and the number of phases and the year of construction. The figure at the side shows the position of the plate, that of the operator respect to the mixer and the AS danger area which must be free from people for a distance A = 250 mm.

Mod.	<input type="text"/>	N.	<input type="text"/>
Hz	<input type="text"/>	Kw	<input type="text"/>
Volt	<input type="text"/>		
CE	<input type="text"/>		

Manufactured in ITALY

**SIGMA**  
BAKERY-PASTRY-PIZZA EQUIPMENT

Via Artigianato 85 - 25030 Torbole Casaglia (BRESCIA) ITALY -  
Tel. +39 030 265 04 79 Fax +39 030 265 01 43

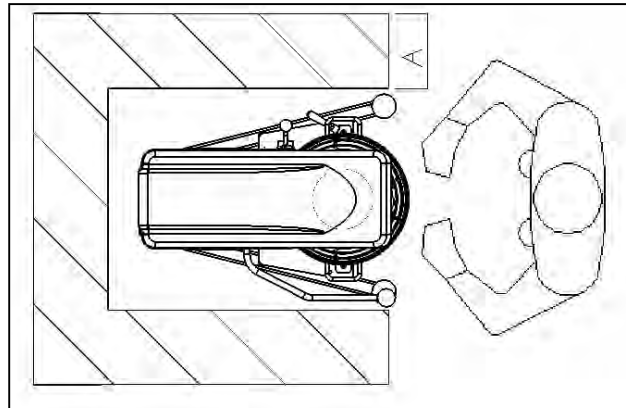

### TECHNICAL DATA, PACKAGING, DIMENSIONS AND WEIGHT.

There are four types of packaging: machine on pallet wrapped in cellophane, machine on pallet in cardboard box, machine on pallet in wooden cage, machine on pallet with crate.

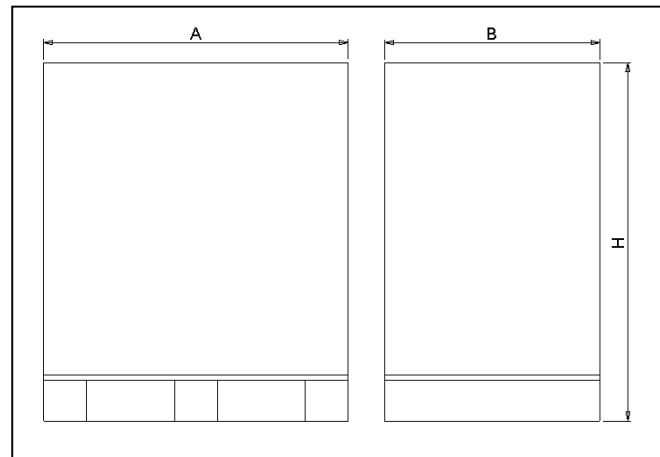
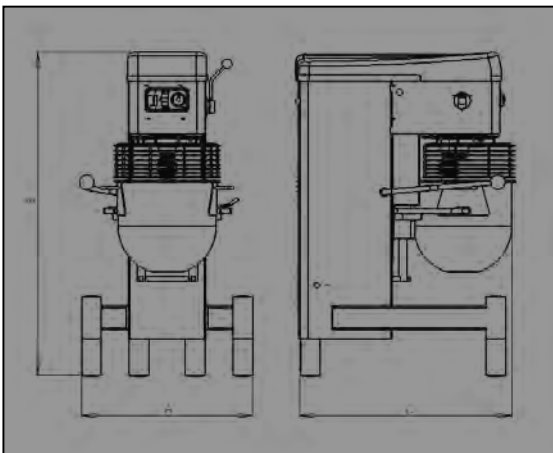

Model	A mm	B mm	C mm	Weight [Kg]	Bowl litres	Power [Kw]
BM 40	700	1290	920	204	40	1,5

Packaging	A mm	B mm	H mm
Pallet + cardboard box	950	740	1610
Cage	1110	900	1550

## TRANSPORTATION AND HANDLING.

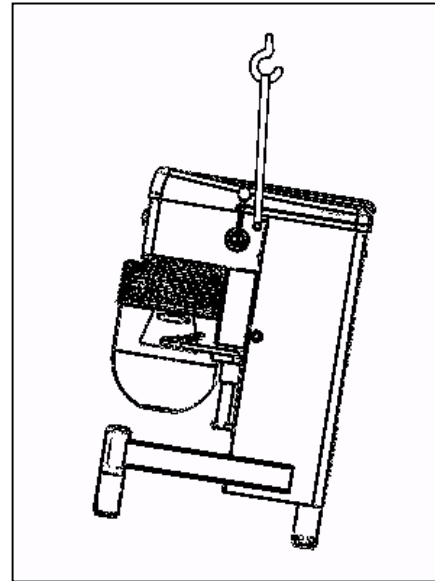
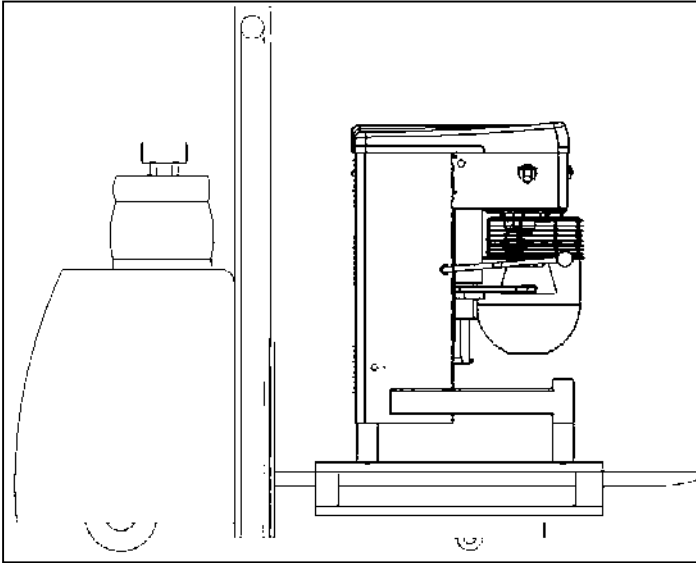

### Machine without pallet.



Due to its instability, the mixer must be handled with a suitably-sturdy strap, having it pass below the head, as in the figure at the right.

Before lifting, stand the grid up vertically

- Make sure the lift equipment is adequate for the load. Work in an empty area. During movement, always keep the load as close to the ground as possible.
- Use the required P.P.E.
- The mixer inclines slightly by 10-15 degrees when lifted.



Lifting standards with lift truck: always use a pallet when handling the mixer.

### Machine on pallet.

- Make sure the lifting device is adequate for the load.
- Widen the lifting forks as much as possible and make sure they come out from the pallet.
- Work in an area free from persons and animals.
- During movement, always keep the load as close to the ground as possible.
- Use the required P.P.E.

## STORAGE:

### Storage of packed mixer:

The mixer must be stored in a closed and covered place, on a smooth and solid surface protected from dust and filth, sheltered from atmospheric agents and hygienically safe.

The temperatures must remain between  $-20$  and  $+50^{\circ}\text{C}$ , and humidity no greater than 90%.

### Storage of unpacked mixer.

If the mixer has already been unpacked, in addition to that above, it must be lifted from the ground with a pallet or other and covered in order to protect it from humidity, dust and filth. If wrapped in cellophane or another type of plastic, avoid airtight closing below the mixer in order to prevent corrosion linked to condensate.



**ATTENTION!** The mixer must not be stored outdoor!!

## INSTALLATION



The mixer must stand in a vertical position, on a smooth surface sufficiently sturdy for the load (floor with resistance over 20 km/cm<sup>2</sup>). If in danger of tipping over, anchor the mixer to the floor using 4 plugs or bolts with a traction resistance over kg 300 (M8).



### Connection to electrical mains

The electrical connection must be carried out by a specialised electrician, according to the modalities and standards in force in the country where it is installed. Make sure that the voltage and frequency of the system are the same as those on the mixer identification plate. Incorrect connection makes the warranty void.



## PRESERVATION OF THE MACHINE

Storage before a long period out of service

Clean the mixer thoroughly.

Disconnect it from the electrical mains.

If possible, put it back into its original packing.

## WARRANTY TERMS

Validity: The warranty starts from the delivery date and lasts 12 months, if:

- The mixer was not damaged during transportation, and it was installed, commissioned, used and serviced as prescribed in this manual.
- It was not tampered with, modified and no unintended tools were installed on it.
- It did not undergo modifications or repairs carried out by the customer or third parties in an incompliant fashion or without the prior consent of the supplier.

The following conditions constitute improper use of the mixer:

- Loading more than what is allowed or use of unsuitable ingredients.
- Cleaning with unsuitable tools or instruments that can scratch the bowl or damage the mixer or paint.
- Use of the mixer in unsuitable places.

### Modality for granting the warranty

If the customer finds defects in the mixer, he must immediately inform the supplier, who will carry out a quick analysis of the lack of compliance and will establish the intervention mode with the customer.

After agreement with the supplier, the customer must provide him with the needed time and opportunity to carry out modifications, improvements, repairs or the supply of spare parts which the supplier deems reasonably necessary. If this does not occur, the supplier will not be held liable.

### Parts subject to wear

Some components are scaled for a life duration far longer than that of normal mixer use during the time of its warranty. Breakage or malfunctioning of these pieces depends on their use. They are therefore considered parts subject to wear and are not included in the warranty, unless they manifest evident defects in the parts or machinery.

The parts subject to wear are: transmission belts, motors, bearings and bowl.

CLEANING AND MAINTENANCE OPERATIONS.



**CONTROL OF INSTALLED SAFETY SYSTEMS AND ELECTRICAL SYSTEM**

The installed safety systems and the electrical system are subject to periodical checks carried out by a specialised electrician.

Key of control intervals: (INTERVAL)	Key of how to carry out the controls: (METHOD)
d = daily. w = weekly. m = monthly. a = annually.	O = observation: requires simple eye check (i.e. alarm light) F = Function: requires a physical control of the action (i.e. pressing the emergency button the mixer must stop) M = Measurements: requires a control with an appropriate instrument (i.e. control of earthing values).

Master switch.

Purpose: protection of power line.

Function: this equipment separates the machinery from the mains, it is placed on the upright of the mixer, downstream the differential protection board.

Control	
Interval	Method
a	F

Stop circuit and safety micro switch of grid.

Purpose: to stop the mixer immediately and unconditionally. Function: pressing the STOP button or lifting the protective grid cuts the motor power, stopping the mixer totally and not systematically. To restore functioning of the machinery, the operator must start the cycle once again by pressing the START button.

Control	
Interval	Method
m	F

Controls of system

Periodically the mixer's automation functioning and earthing must be checked. The operating modes, safety functions, terminal board contacts need to be controlled as well as the integrity of the cables, luminous LEDs and earthing system.



Control	
Interval	Method
a	F, M

ROUTINE MAINTENANCE.

**DO NOT CARRY OUT ANY MAINTENANCE OR CLEANING WITH ELECTRICITY CONNECTED**

DO NOT CARRY OUT ANY MAINTENANCE OR CLEANING WITH ELECTRICITY CONNECTED The mixer does not require particular maintenance operations. After the first three months of work, check the wear of the belt.

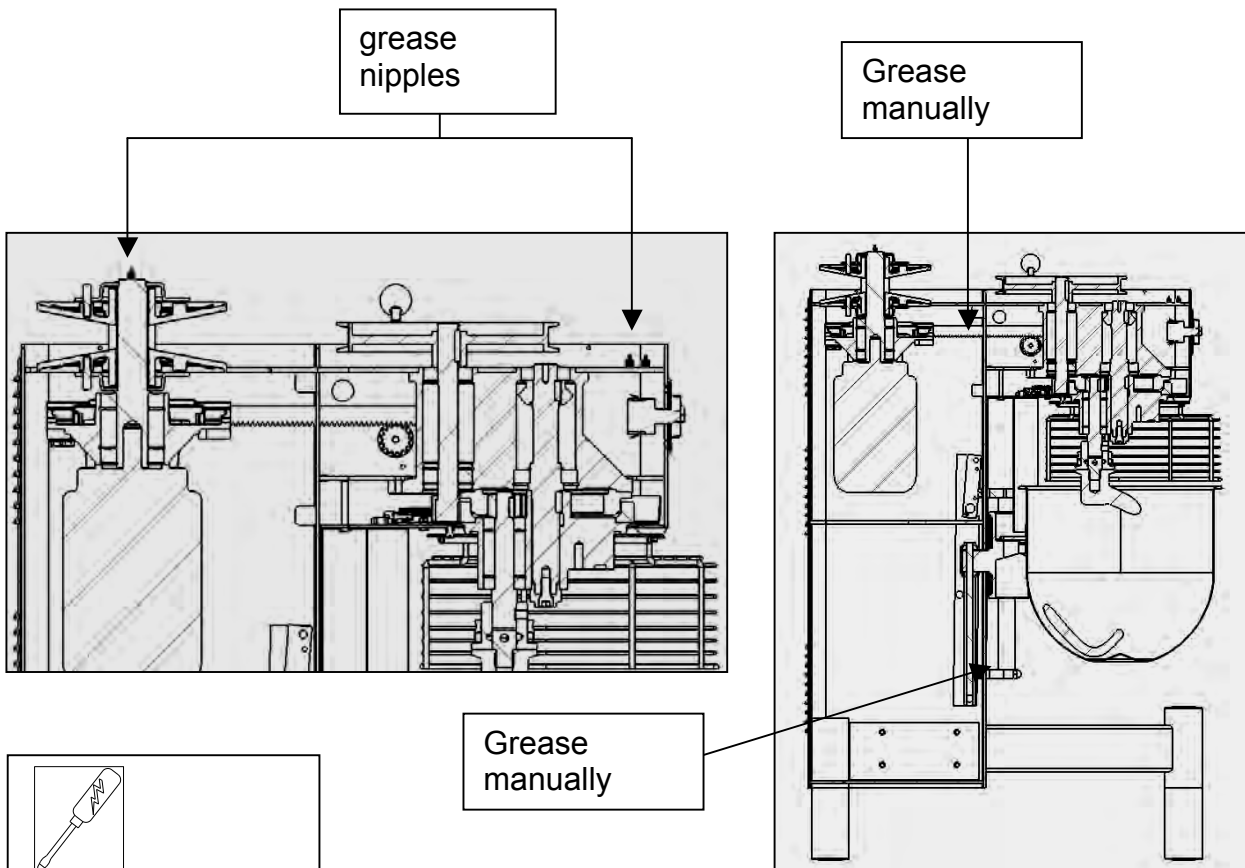
Every 4 ÷6 months, grease and oil the points indicated in the following layout (use **MOLYKOTE 165 LT** grease).





Should a power cable be damaged, replace it with a H07RN/F cable with a 3x1.5 mm<sup>2</sup> section.

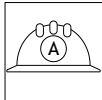

**Cleaning:** the mixer is not jet-proof. Do not wash it with running water. Clean it with a moist cloth and neutral detergents, such as degreasing agents based on Castile soap

EXTRAORDINARY MAINTENANCE:



To carry out interventions not specially mentioned in the manual, refer to personnel authorised by SIGMA SrL. To replace the motor or the circuit boards, or else if the mixer falls, contact our assistance service for an intervention on site or else an overhaul at the factory

## PERIODICAL MAINTENANCE.

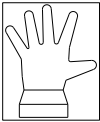

### DAILY CLEANING AND CONTROL OPERATIONS:

- Cleaning outside surfaces of the bowl and tools with cloth and neutral degreasing agent.
- Operative and emergency controls check.

## MONTHLY, ANNUAL MAINTENANCE OPERATIONS



### Monthly maintenance:

- Thorough cleaning of the mixer.
- Operative and emergency controls functioning check.
- Mixer's external components' check: tools, bowl, protective grid.
- Transmission noise check.

### Annual maintenance:

- Thorough cleaning and check of entire machinery.
- Thorough check of transmission organs.
- Bolt tightening check for entire machinery.

### Bolt tightening torques.

	M6	M8	M10	M12	M14	M16
Mixer screws (8.8) [Nm]	9.7	23	47	80	130	196
Stop rod screws (10.9) [Nn]	13.6	33	6	113	180	275
<b>Mixer screws A2 [Nm]</b>						



- Installed safety systems check.

## SPARE PARTS:

SIGMA SrL reserves the right to carry out all the modifications that it deems necessary for its mixer models. It is therefore always necessary to specify:

- Type of mixer
- Serial number
- Year of construction
- Position, description, item code and desired amount of pieces requested.

Send the request to: Sigma SrL via Artigianato 85, 25030 Torbole Casaglia (BS) Italy

## MAIN COMPONENTS:

- Raw materials used: almost all of the components of the mixer are made of steel, cast iron, brass and plastic. All of these components can be disposed of easily and do not represent a danger for environmental pollution and/or personal safety. Separate the different materials for subsequent reuse or differentiated waste collection.
- The electrical system must be dismantled and disposed of through a specialised company.
- Treatment of surfaces: painting of metallic surfaces with products compatible for food use.
- Sigma packaging replies fully with that required by Directive 94/62/EC and by Legislative Decree 05/02/97 n. 22 (and subsequent amendments and integrations). They thus can easily be assimilated with city waste and can be inserted in any public differentiated waste program.

## DISMANTLING AND WASTE DISPOSAL:

The purchaser is responsible for putting the mixer out of service, who must comply with local standards and regulations. Dismantling of mechanical and electrical parts must be entrusted to competent personnel.

SPARE PARTS LIST \*

*\*: this is a brand new generation of Sigma planetary mixers, the following chart can be little bit different from the machine you have. In case contact the factory to get the updated one. We will soon provide you the real line diagrams of it.*

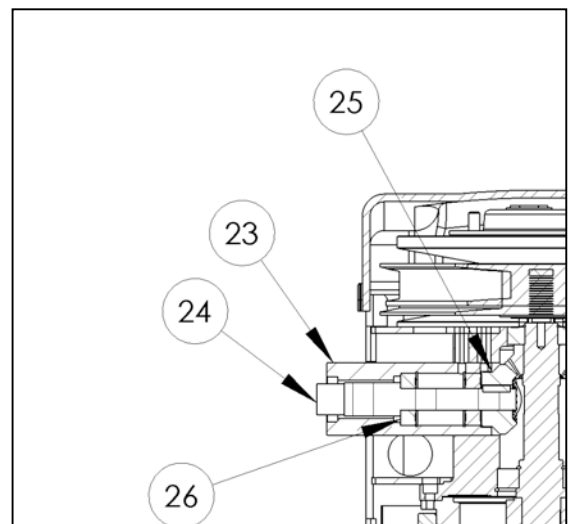
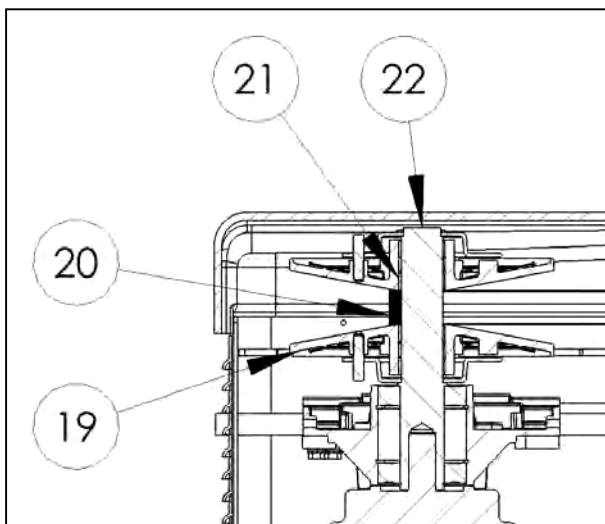
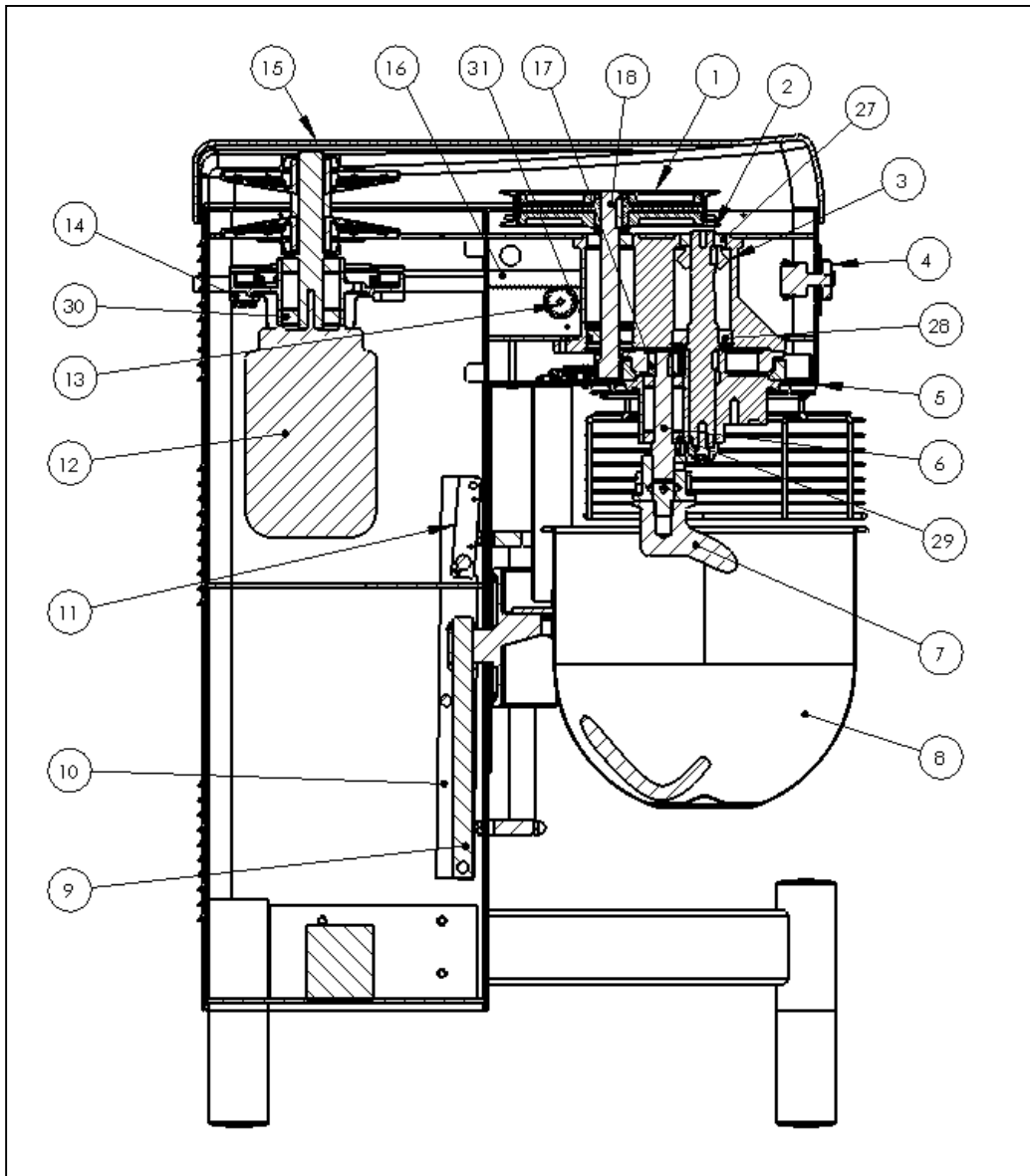





SPARE PARTS LIST TABLE:

<b>Position</b>	<b>Quantity</b>	<b>Code</b>	<b>Description</b>
1	1	095016-A	Driven pulley BM-40
2	1	101022-5	Planetary shaft BM-60
3	1	101023-2	Driving bevel gear Z22 BMX-60 version with reduction gear
4	1 1 1 1	097201	Silkscreen printing BM-20 Timer START/STOP button ON/OFF switch
5	2 4 2	194021-1 194022-1 194023-1	Long grid wheel pin Grid guide wheel Short grid wheel pin
6	1	095020-2	Tool holder shaft BM-40
7	1 1 1	095058 095216 095217	Thin wire whisk BM-40 Cast blade BM-40 Cast spiral BM-40
8	1	095122-1	Bowl BM-40
9	1	095050-2	Bowl lifting rod BM-40
10	2	095049-3	Bowl lifting plate BM-40
11	4	095052-1	Plate distance pad
12	1	MARKET	Motor Gr.90 B14 for BM-40
13	1	095036-2	Cogwheel Z15
14	1	095008-9	Motor seat BM-40, BM-60
15	1	095208-1	Top casing BM-40
16		101181-1	2.5 module rack for BM-40
17	1	097013-4	Planetary pinion BM-20
18	1	101070-2 (50 Hz) 101017-3 (60 Hz)	Countershaft BM-60
19	2	095013-5	Variable semi-pulley BM-40
20	1	095080-3	Variator belt 33x10x1322
21	4	MARKET	38x42x15 bushes
22	1	095012-7	Variable pulley shaft BM-40
23	1	185016	Reduction gear support
24	1	185017	Reduction gear connection shaft
25	1	097016-3	Driven bevel gear Z22 M3
26	2	MARKET	Bearings 47-20-14 (6204)
27	1	MARKET	Bearings 30-62-16 (6206)
28	1	MARKET	Bearings 80-40-18 (6208)
29	2	MARKET	Bearings 52-25-15 (6205)
30	2	MARKET	Bearings 80-40-18 (6208)
31	2	MARKET	Bearings 62-25-17 (6305)

BLOCKAGE OF MACHINERY AND NECESSARY REMEDIES

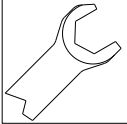
OPERATION ANOMALIES	POSSIBLE CAUSES	REPAIR
Turning the master switch into position, the warning light does not turn on	1) Plug not inserted correctly or wires detached	1) Check connection 
Pressing the START button, the mixer does not start	1) The slide is not in position or the front grid is not closed 2) Safety micro switch anomalies	1) Lift the slide and reposition it after having closed the front grid 2) Replace the micro switch 
Intermittent noise	1) Lack of grease in transmissions (gears)	1) Grease as shown in previous layout (page 13)
Continuous noise	2) Check the efficiency of the bearings	1) Replace the bearings 

ELECTRICAL LAYOUT:

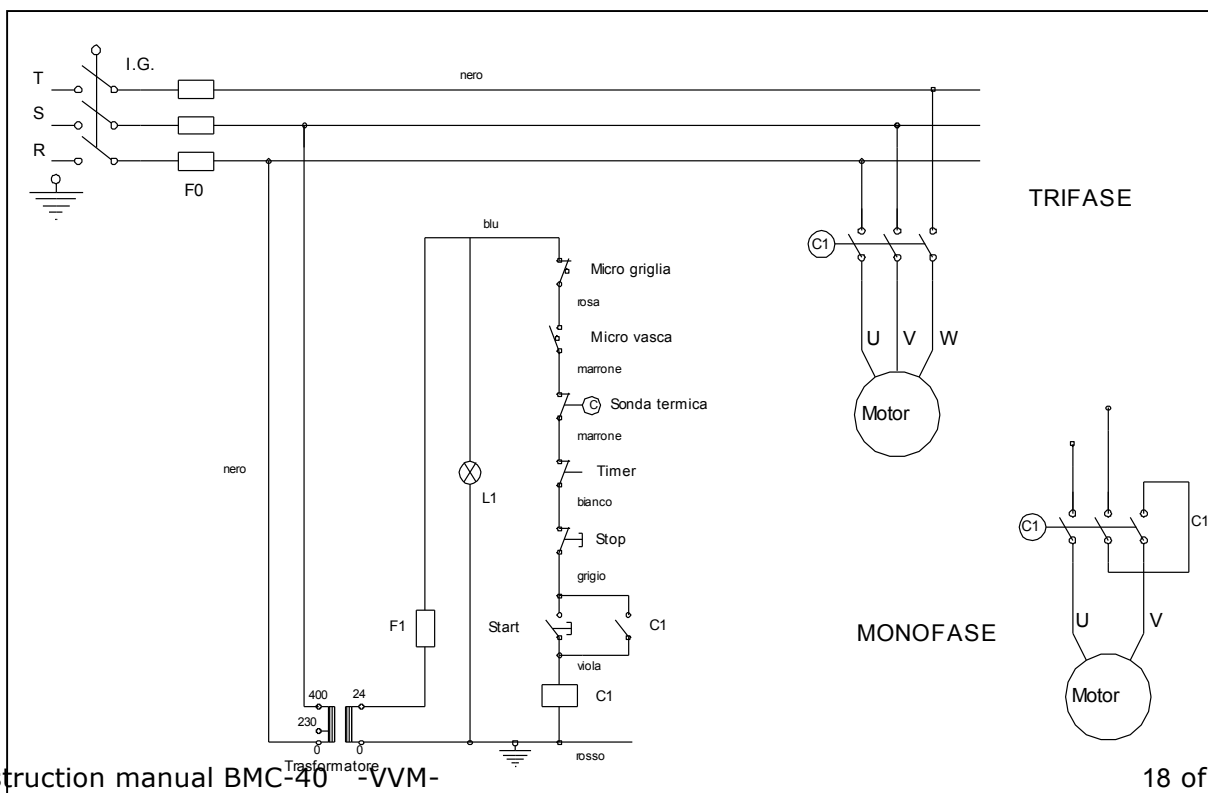

# Obligations of informing users

Information model for users of “professional” products



## INFORMATION FOR USERS

***In compliance with art. 13 of the Legislative Decree of July 25, 2005, n. 151 “Implementing of Directives 2002/95/EC, 2002/96/EC and 2003/108/EC, relative to the reduction of the use of hazardous substances in electrical and electronic appliances as well as disposal of waste”***

The symbol of the barred waste bin on the appliance or its packaging indicates that the product at the end of its useful life it must be disposed of separately from other waste.

Differentiated waste collection of this appliance having reached the end of its life is organised and managed by the manufacturer. The user who desires to dispose of the present appliance must therefore contact the manufacturer and abide by the system that has been chosen to allow separate collection of the appliance when reaching the end of its life.

Adequate differentiated waste collection for successive recycling, treatment and environmentally compatible disposal contributes to prevent negative effects on the environment and on human health and favours the reuse and/or recycling of the materials making up the appliance.

Illicit disposal of the product by the user entails the application of administrative sanctions foreseen by Standards in force.