

Item no.	Part no	Reference	Description
1		►1	Control panel
2		►2	Electrical installation
3		►3	Clima Plus
4		►4	Steam generator, Bypass
5		►5	Hot air heating
6		►6	Motor and fan wheel
7		►7	Interior cabinet
8		►8	Door
9		►9	Water supply, quenching box
13		►13	Exterior cabinet
14		►14	Miscellaneous
15		►15	Voltage depending parts

1	Control panel	3
1.A	Control panel.....	4
2	Electrical installation	5
2.A	- EM CM 062/E 3NAC400V50-60 01/04.....	6
2.B	Cable entry.....	7
3	Clima Plus.....	8
4	Steam generator, Bypass	9
4.A	Pump connection	10
5	Hot air heating	11
6	Motor and fan wheel	12
7	Interior cabinet	13
7.A	Gasket frame w. glass a. gaskets	14
7.B	Air baffle	15
8	Door	16
8.A	Door	17
9	Water supply, quenching box.....	18
13	Exterior cabinet.....	19
13.A	- P-Außenkasten CD 062/E 01/04.....	20
14	Miscellaneous	22
15	Voltage depending parts	23

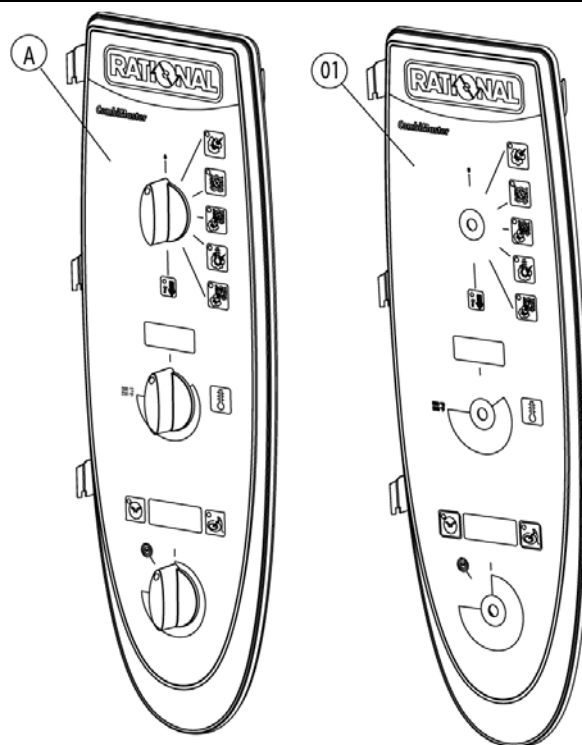

Item no.	Part no	Reference	Description
A	16.00.324	▶1.A	Control panel
1	87.00.001		Control panel insert with overlay

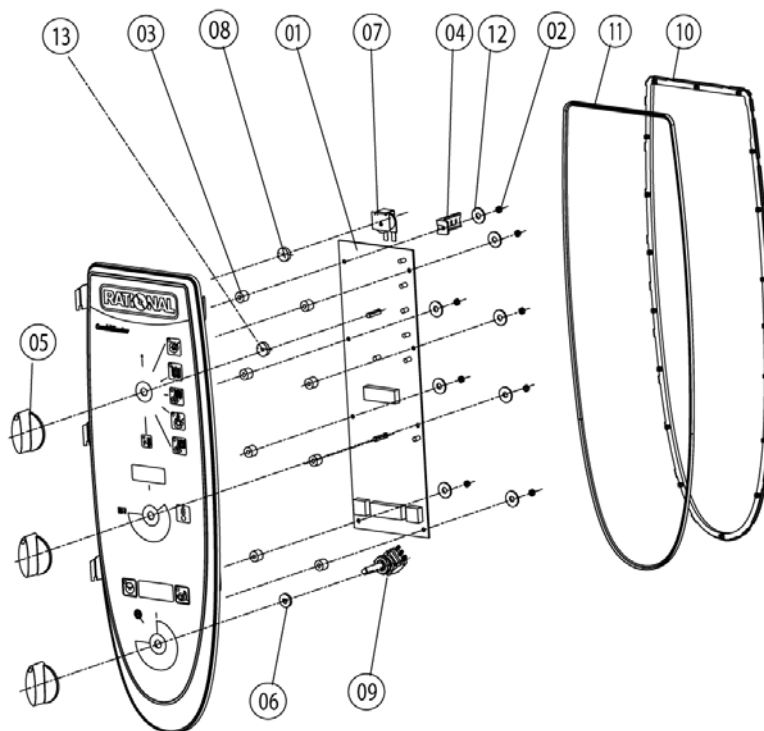

Item no.	Part no	Reference	Description
1	42.00.004		Control pcb
2	1104.0121		Hex nut M4 self locking
3	10.00.355		Spacer black
4	2020.0400		Fixing device for cable harness
5	16.00.282		Dial
6	5110.1027		Distance plate for front panel
7	3006.0107		Buzzer
8	5110.1028		Gasket poti hot air, core temperature
9	40.00.464		Potentiometer CT
10	16.00.385		Mounting device f. sealing lip panel insert
11	16.00.386		Sealing lip f. panel insert
12	1306.0218		Washer A4,3
13	5110.1029		Gasket mode switch

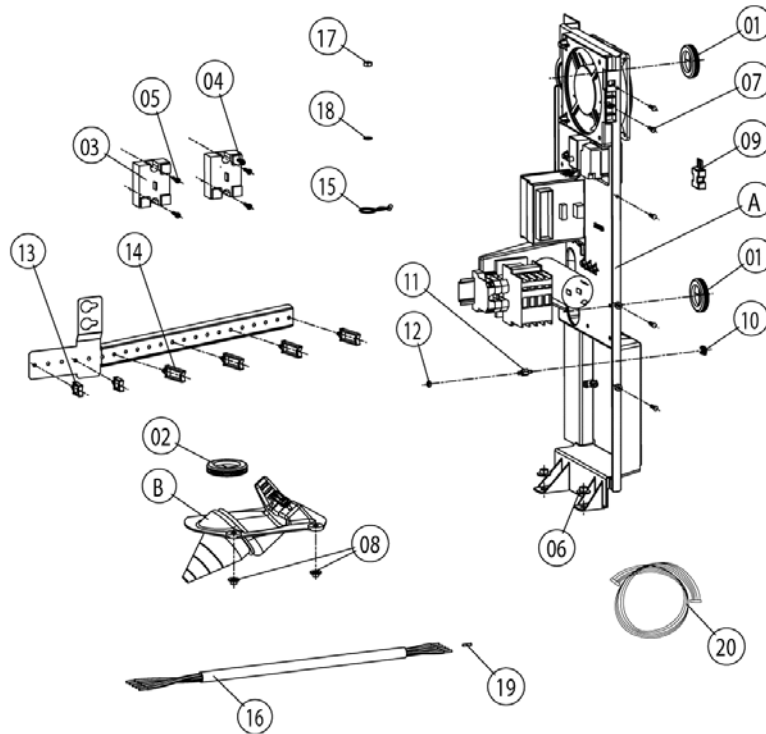

Item no.	Part no	Reference	Description
A	_40.01.081	►2.A	- EM CM 062/E 3NAC400V50-60 01/04
B	40.00.306	►2.B	Cable entry
1	4007.0620		Membrane DGC 29
2	4007.0621		Membrane DGC 36
3	40.00.453		Solid state relays
4	10.00.507		- Zylinderschraube 8-32NC, 5/16" T20 k=10mm
5	10.00.444		Raised countersunk head screw Torx M4x8
6	1106.0803		Hex combination nut M6 galv
7	10.00.239		EJOT PT-Screw Torx 4x10
8	1105.0121		Hex combination nut M5 galv
9	42.00.007		External memory
10	1104.0801		Cage nut M4
11	10.00.243		Spacer M4x8
12	1104.0120		Hex nut M4
13	10.00.112		Cable clip short
14	10.00.111		Cable clip long
15	10.00.471		Cable clip d10-12mm
16	8801.0136		Power supply cable 5x4mm ² 3m
17	1106.0160		Hex nut M6
18	1206.0120		Tooth lock washer A6,4
19	4004.0103		Wire end sleeve 4,0 mm ²
20	40.00.472		Bus cable 1.3m
--	42.00.030		- Memory-Stick CM 01/04

Attention! Individual parts shown might not be used in this component group!

► 15* Voltage depending parts shown in chapter 15

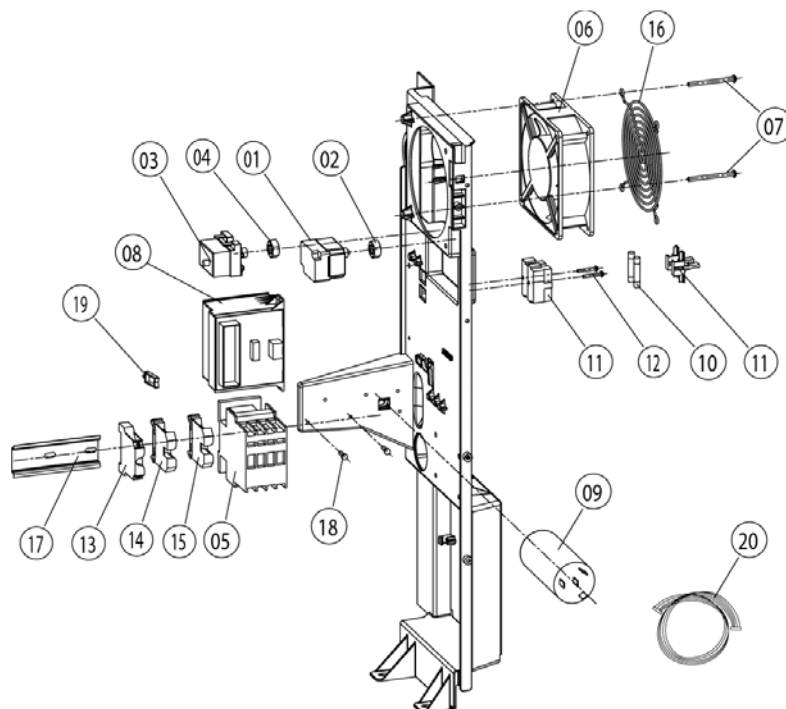

Item no.	Part no	Reference	Description
1	40.01.329		Dry up protector 160°
2	3014.0302		Hex nut M10 for dry-up protector
3	40.00.605		Safety temperature limiter 365°C
4	3014.0327		Hex nut M10x1,0
5	40.01.555		- Schütz CL02A310T6-M 01/04
6	3101.1008		Cooling fan
7	10.00.238		Screw Torx 4x50
8	40.00.278		Halogen transformer
9	40.00.465		Electronic noise filter
10	4001.0224		Fuse 6.35x32mm
11	4001.1295		Fuse holder e 1003Si/1DS
12	10.00.240		Screw Torx 3x20
13	4001.1210		Earth terminal 16mm ² yellow/green
14	4001.1250		Terminal block 16mm ² blue
15	4001.1206		Terminal block 35mm ² grey
16	2005.0106		Protective grid for cooling fan
17	40.00.518		Installation rail for Contactor 95mm
18	10.00.239		EJOT PT-Screw Torx 4x10
19	10.00.111		Cable clip long
20	40.00.212		Cable buzzer
20	40.00.228		Cable control SSR
20	40.00.205		Cable level electrode
20	40.00.219		Cable SC pump
20	40.00.236		Cable solenoid valve

Attention! Individual parts shown might not be used in this component group!

► 15* Voltage depending parts shown in chapter 15

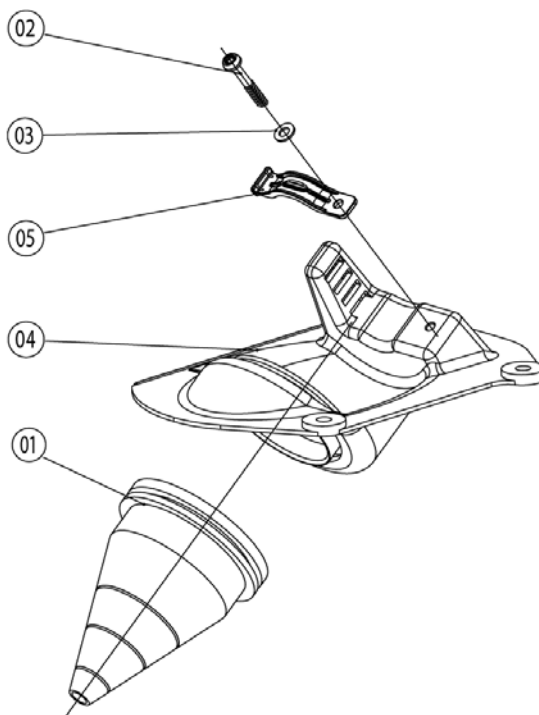

Item no.	Part no	Reference	Description
1	40.00.391		Cable bushing f. cable entry
2	10.00.115		Allen screw M5x30
3	1305.0160		Washer A5,3 x 10 mm
4	40.00.307		Cable entry
5	40.00.312		Clamp strap f. cable entry

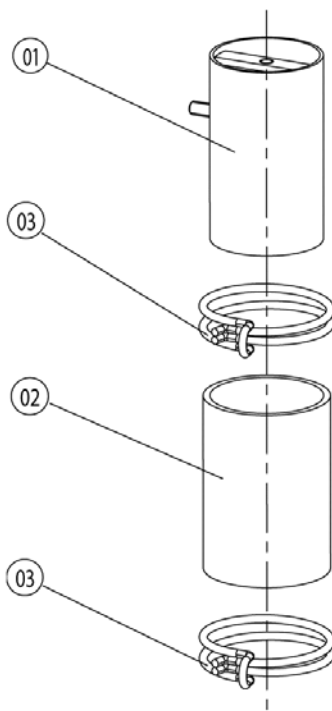

Item no.	Part no	Reference	Description
1	22.00.324		Safety valve
2	22.00.174		Hose d50x83
3	2066.0531		Hose clamp ø56

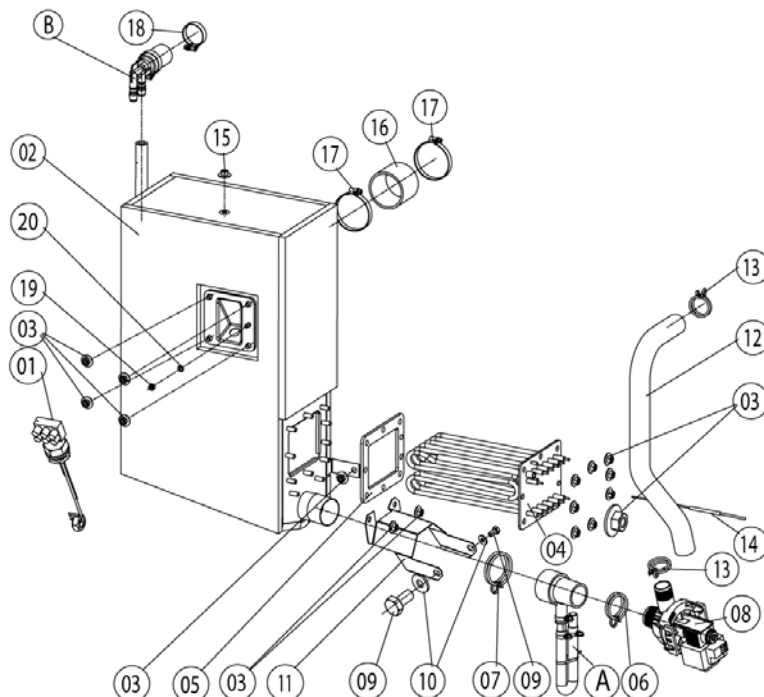

Item no.	Part no	Reference	Description
A	_8354.1320	►4.A	Pump connection
1	3002.0402		Filling level electrode 90 mm
2	44.00.172		Steam generator insolated
3	1106.0803		Hex combination nut M6 galv
4	44.00.195		Heating element
5	44.00.279		Gasket f. heating element
6	2066.0519		Hose clamp 35,6mm
7	2066.0526		Hose clamp ø46mm
8	44.00.207		Emptying pump
9	1006.0762		Hex screw M6x10
10	1306.0222		Washer A6.4x15x1.5
11	44.00.278		Fixing device f. pump steam generator
12	44.00.212		Drain hose steam generator
13	2066.0518		Hose clamp 30mm
14	40.00.291		Thermocouple steam generator
15	1104.0122		Hex combination nut M4 galv
16	2112.1006		Steam hose 50x7mm
17	2066.0504		Hose clamp 40-60mm
18	2066.0506		Hose clamp 20-32mm
19	1105.0120		Hex nut M5
20	1205.0120		Tooth lock washer A5,3

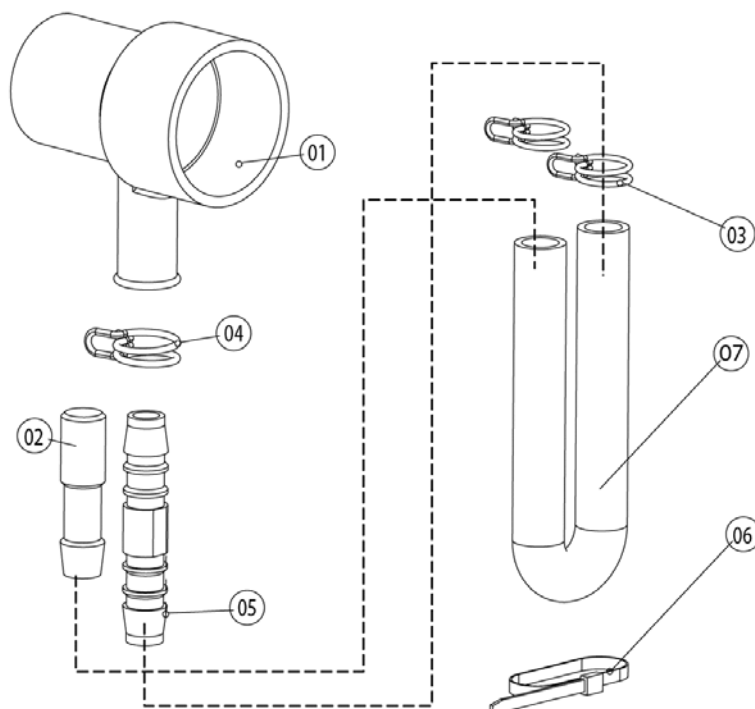

Item no.	Part no	Reference	Description
1	2118.1000		Pump connection spout
2	2120.1259		Stop plug 10mm
3	2066.0527		Hose clamp \varnothing 14mm
4	2066.0530		Hose clamp \varnothing 16.4mm
5	2062.0331		Junction pressure hose GS 10
6	4005.0101		Tie rap 145 mm
7	2110.1008		Silicon hose \varnothing 10x2mm

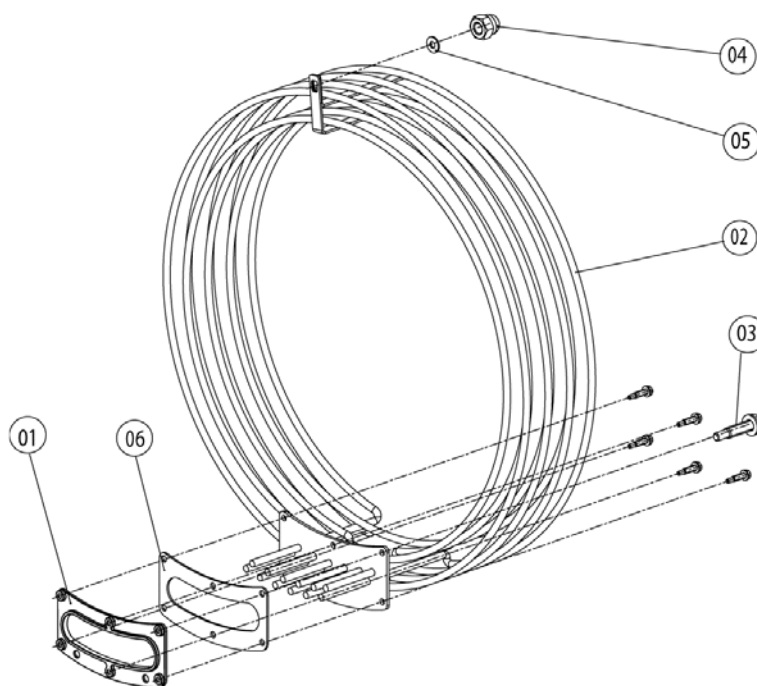

Item no.	Part no	Reference	Description
1	40.00.305		Mating flange f. heating assembly
2	40.00.263		Heating assembly
3	10.00.109		Hex screw M5x23
4	1106.0360		Cap nut M6, high shape
5	1306.0222		Washer A6.4x15x1.5
6	40.00.332		Gasket f. heating assembly

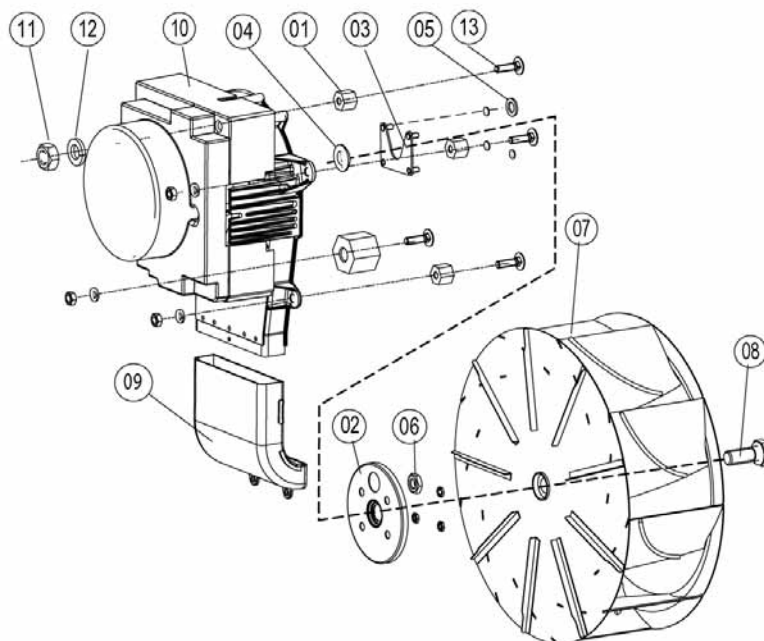

Item no.	Part no	Reference	Description
1	2120.1306		Spacer SW19x17
2	22.00.123		Flange f. motor shaft gasket
3	22.00.120		Mounting support f. gasket flange
4	22.00.083		Motor shaft gasket
5	1315.0101		Copper washer 6x10
6	1106.0220		Hex nut M6 flat
7	22.00.192		Fan wheel d340x135
8	1008.0763		Hex screw M8x20
9	40.00.310		Exhaust pipe below
10	40.00.274		Fan motor
11	1108.0260		Hex nut M8
12	1208.0260		Spring washer B8
13	1008.1005		Square necked mushroom head bolt 8x40

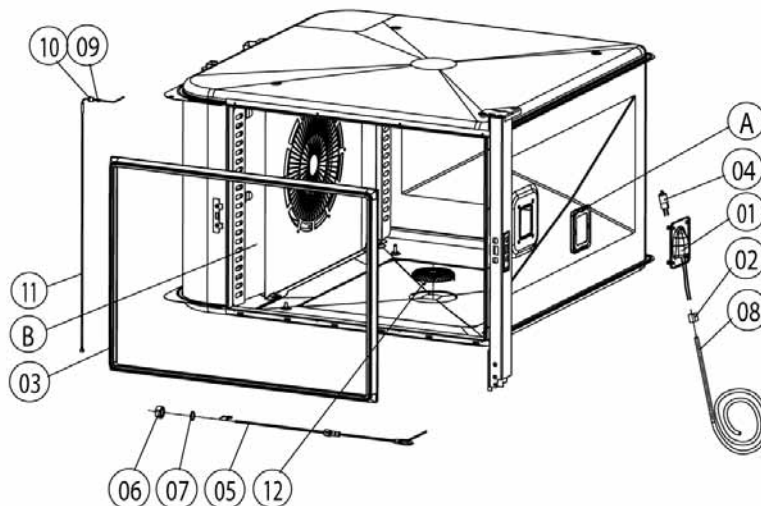

Item no.	Part no	Reference	Description
A	40.00.091	►7.A	Gasket frame w. glass a. gaskets
B	22.00.294	►7.B	Air baffle
1	40.00.098		Reflector f. interior light
2	4001.1248		Porcelain connector 2-pin interior light
3	20.00.395		Door gasket
4	3024.0201		Halogen bulb for interior cabinet
5	40.00.297		Meat probe sensor
6	10.00.422		Hex nut M16
7	1315.0104		Copper washer 16x20x1,5
8	40.00.222		Wiring interior light
9	3014.0162		Sealing cone for thermocouple
10	3014.0163		Gasket sleeve with nipple
11	40.00.395		Thermocouple interior cabinet
12	2005.0308		Outlet sieve

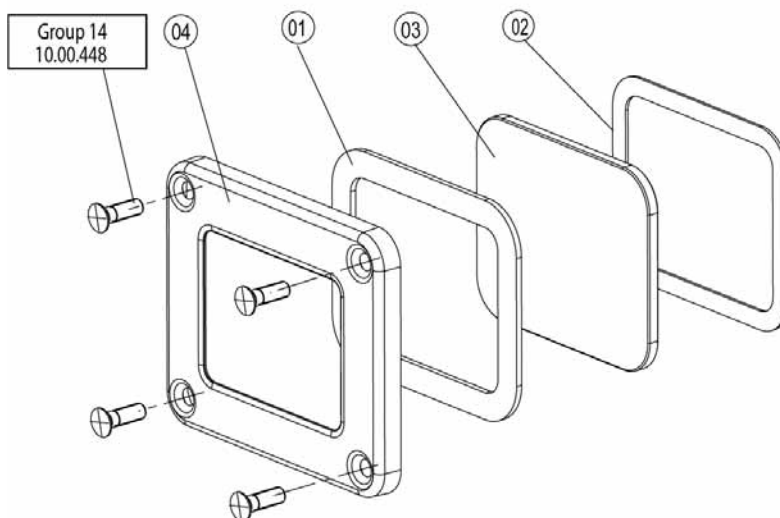

Item no.	Part no	Reference	Description
1	40.00.093		Outer gasket f. interior light
2	40.00.094		Inner gasket f. interior light
3	40.00.095		Glass pane f. interior light
4	40.00.096		Gasket frame f. interior light

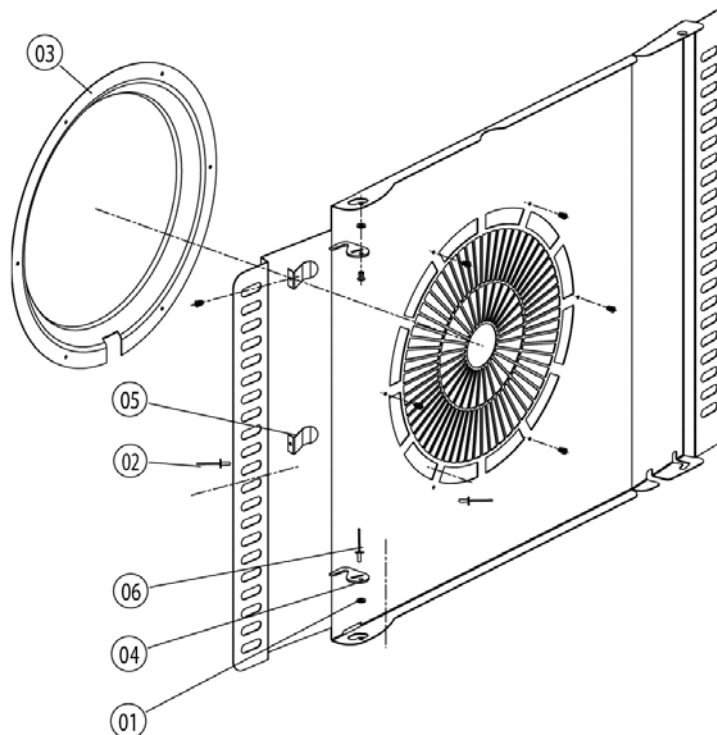

Item no.	Part no	Reference	Description
1	1304.0160		Washer A4,3
2	1604.0167		Rivet 4x10
3	22.00.332		Air sucking ring f. air baffle
4	2760.1370		Latch hook for air baffle
5	40.01.289		Fixing clip core temp. cable
6	1603.0168		Rivet 3,2x8 A4

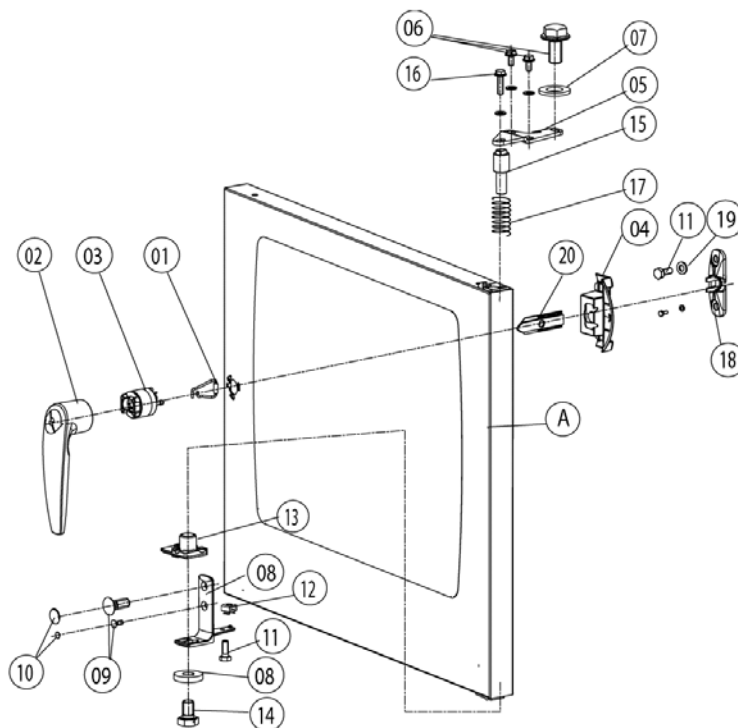

Item no.	Part no	Reference	Description
A	24.00.105	►8.A	Door
1	24.00.506		Spring clip f. door lock
2	24.00.152		Door handle
3	24.00.176		Door lock
4	24.00.504		Lock cover
5	24.00.133		Door mounting support top
6	1008.0768		Ornamental screw M8x16
7	1308.0160		Washer A8,4
8	24.00.223		Door mounting support bottom
9	1006.1962		Countersunk screw Torx M6x16
10	10.00.090		Cap f. Torx T30
11	1006.0760		Hex screw M6x16
12	1106.0802		Cage nut M6
13	24.00.137		Door bolt
14	10.00.099		Hex screw M8x12
15	24.00.048		Door bolt
16	1008.0769		Ornamental screw M8x30
17	2001.0109		Compression spring
18	24.00.141		Holding bracket f. door catch
19	1306.0120		Washer A6,4
20	24.00.142		Door catch

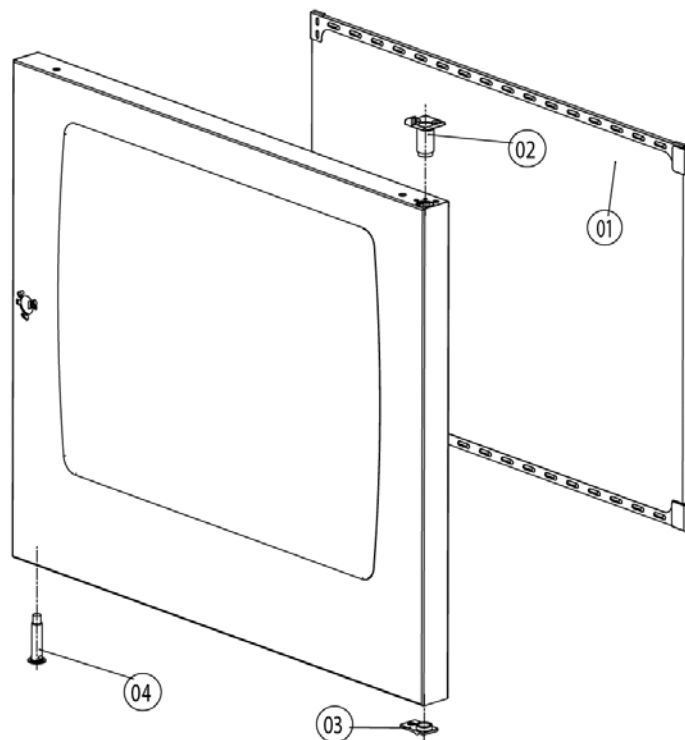

Item no.	Part no	Reference	Description
1	24.00.198		Inner glass pane
2	24.00.147		Sleeve for door bolt top
3	24.00.146		Door setting bolt
4	24.00.502		Fixing device f. magnet

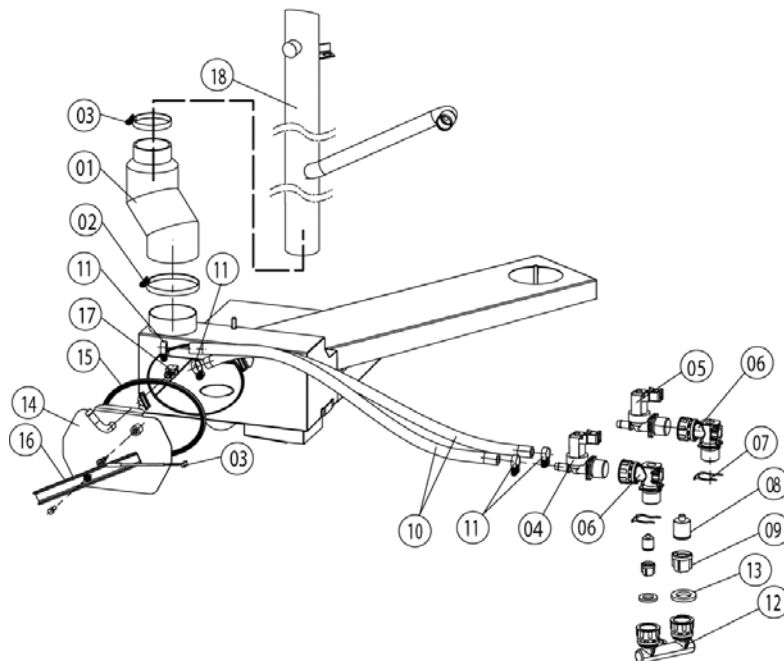

Item no.	Part no	Reference	Description
1	54.00.241		Rubber form piece venting pipe
2	2066.0516		Hose clamp 60-80 mm
3	40.00.287		Thermocouple quenching
4	50.00.316		Single solenoid valve
5	50.00.139		Single solenoid valve
6	50.00.071		Water distribution hor. w/o roll guide con.
7	50.00.086		Locking plate f. water distribution
8	50.00.078		Non return valve DW16/DN12
9	1900.0202		Water filter
10	2067.0050		Pressure hose d10mm
11	2066.0205		Hose clamp 8-16x9 mm SW 7mm
12	8664.1301		T-fitting water connection
13	5110.1024		Gasket for G3/4" threaded joint
14	54.00.228		Inspection lid f. quenching chamber
15	5012.0566		Gasket quenching chamber O-ring
16	54.00.225		Clamping bar
17	2016.0935		Quenching nozzle 2.3 l/min.
18	54.00.221		Exhaust pipe

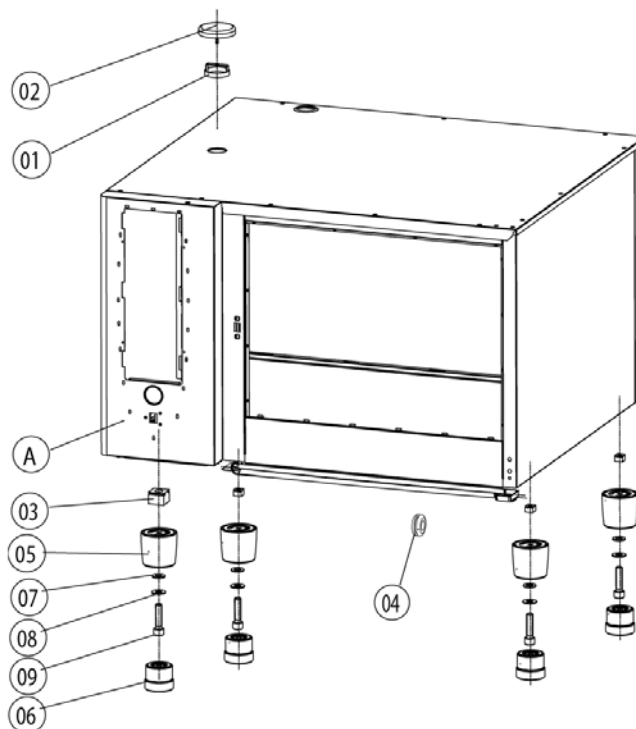

Item no.	Part no	Reference	Description
A	_16.00.368	►13.A	- P-Außenkasten CD 062/E 01/04
1	8450.1310		Spacer ring
2	8455.1209		Vent cover
3	1110.0800		Cage nut M10
4	2022.0101		Grommet 18 mm
5	12.00.205		Upper part of pedestal
6	12.00.206		Lower part of pedestal
7	1310.0160		Washer A10,5
8	1328.0102		Safety washer A10,2
9	10.00.107		Allen screw M10x30

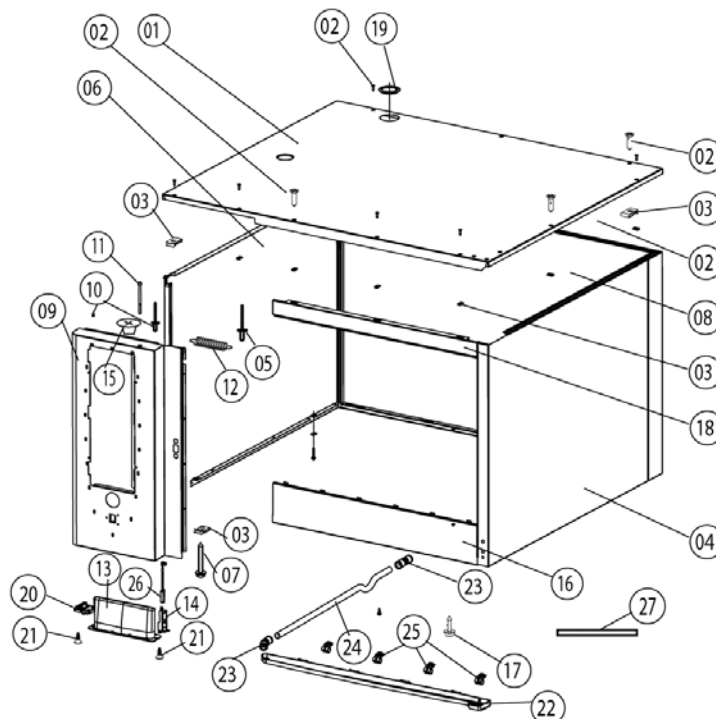

Item no.	Part no	Reference	Description
1	16.00.312		Top cover
2	1003.2265		Countersunk self tapping screw 4,2x16
3	1104.0820		Snap nut 4.2mm
4	16.00.146		Side panel right
5	1603.0166		Rivet 3.2x7,9, CNS closed
6	16.00.147		Side panel left
7	10.00.102		Hex self tapping screw 4,2x32
8	16.00.201		Back panel
9	16.00.297		Front panel
10	1603.0161		Rivet 3,2x6
11	10.00.069		Slotted pan head screw M6x90
12	2002.0107		Tension spring for front panel
13	16.00.673		Air inlet filter
14	16.00.384		Bracket for door contact switch
15	2039.0331		Cap for service door
16	16.00.323		Crossbar below
17	1004.2160		Hex self tapping screw 4,2x16
18	16.00.186		Crossbar top
19	5105.1027		Gasket f. exhaust pipe d=54mm
20	16.00.360		Cover f. RS232 interface
21	10.00.103		EJOT PT-screw KA 3.5x10
22	50.00.300		Drip collector
23	50.00.303		Bushing drip collector
24	50.00.304		Drain drip collector
25	50.00.296		Clip f. drip collector
26	40.00.454		Door switch 1.65m

Attention! Individual parts shown might not be used in this component group!

► 15* Voltage depending parts shown in chapter 15



CM 62 E

Valid as of E62ME0404 up to E62ME....

Electrical unit

▶ **13.A - P-Außenkasten CD 062/E 01/04**

13

13 Exterior cabinet

Voltage **3 NAC 400V 50-60Hz**

Item no.	Part no	Reference	Description
27	16.00.338		Edge protection profile

Attention! Individual parts shown might not be used in this component group!

▶ 15* Voltage depending parts shown in chapter 15

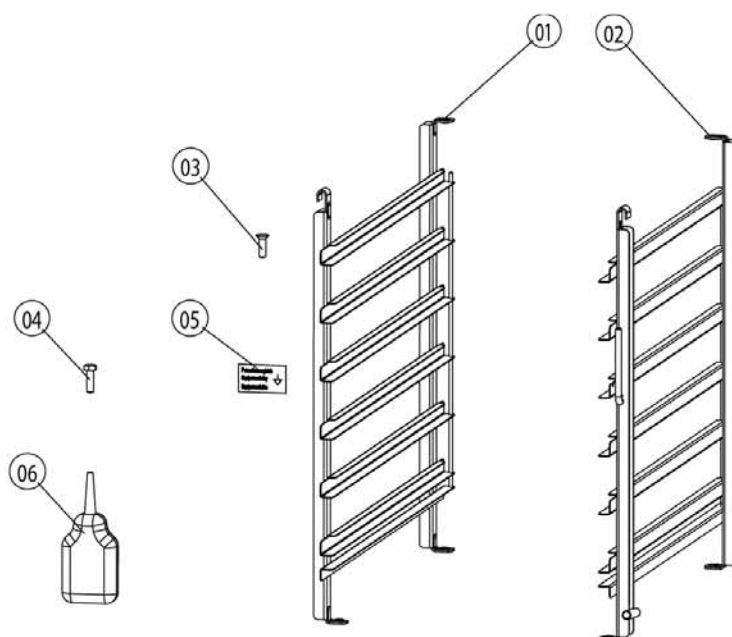

Item no.	Part no	Reference	Description
1	60.62.001		Hinging rack left
2	60.62.002		Hinging rack right
3	10.00.448		Phillips countersunk-head screw M5x16
4	1008.0750		Hex screw M5x16
5	2049.0817		Sticker, Equipotential bonding
6	5006.0202		Loctite IS 495



CM 62 E

Valid as of up to

Electrical unit

▶ **15 Voltage depending parts**

0

0 Voltage depending parts

Voltage **3 NAC 400V 50-60Hz**

Item no.	Part no	Reference	Description
----------	---------	-----------	-------------

Attention! Individual parts shown might not be used in this component group!

▶ 15* Voltage depending parts shown in chapter 15



xxxx

0 xxxx

0

Elektrogeräte

▶ **0 xxxx**

0

Gültig von
xxxx

bis:
xxxx

Spannung: **xxxx**

Attention! Individual parts shown might not be used in this component group!

▶ 15* Voltage depending parts shown in chapter 15