

Item no.	Part no	Reference	Description
1		►1	Control panel
2		►2	Electrical installation
3		►3	Clima Plus
4		►4	Steam generator, Bypass
5		►5	Hot air heating
6		►6	Motor and fan wheel
7		►7	Interior cabinet
8		►8	Door
9		►9	Water supply, quenching box
10		►10	Hand shower
11		►11	CleanJet
13		►13	Exterior cabinet
14		►14	Miscellaneous
15		►15	Voltage depending parts

1	Control panel	3
1.A	Control panel.....	4
2	Electrical installation	5
2.A	- EM SCC 201/E 3NAC400V50-60 01/04.....	7
3	Clima Plus.....	9
3.A	Hose set f. humidity control	10
4	Steam generator, Bypass	11
4.A	Pump connection	12
5	Hot air heating	13
6	Motor and fan wheel	14
7	Interior cabinet	15
7.A	Interior cabinet welded	16
7.B	Gasket frame w. glass a. gaskets	17
7.C	Air baffle.....	18
8	Door	19
8.A	Door	21
8.B	Door catch.....	22
9	Water supply, quenching box.....	23
10	Hand shower.....	25
11	CleanJet.....	26
13	Exterior cabinet.....	27
13.A	- P-Außenkasten CPC 201/E 01/04	28
14	Miscellaneous	29
15	Voltage depending parts.....	30

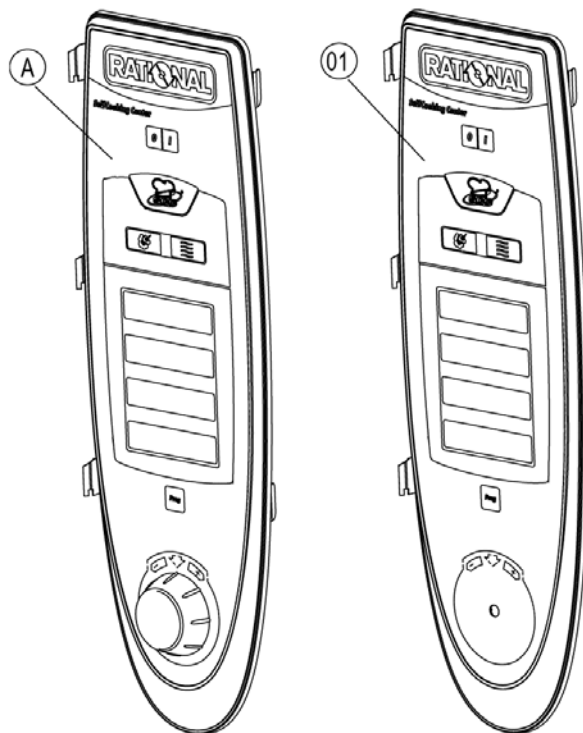

Item no.	Part no	Reference	Description
A	16.00.263	▶1.A	Control panel
1	87.00.000		Control panel insert with overlay

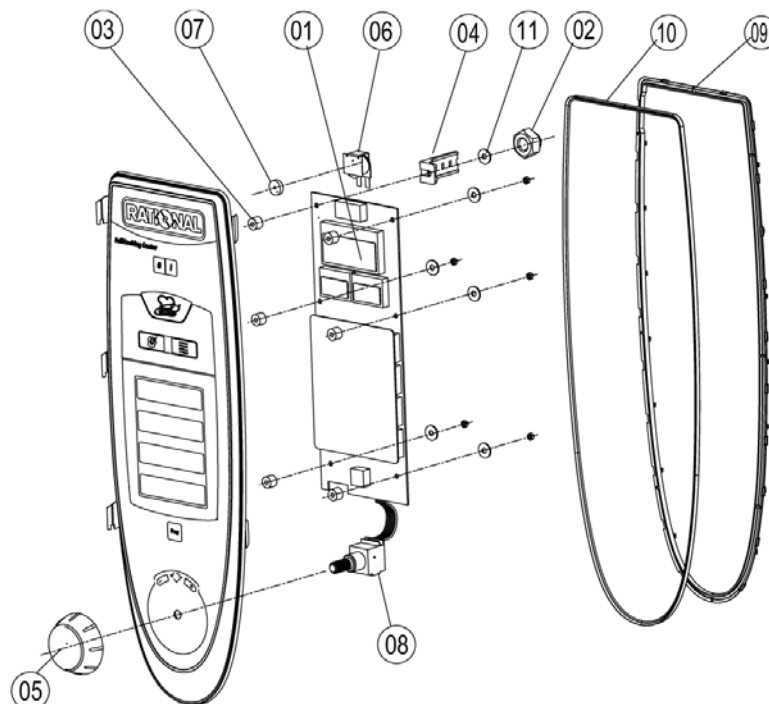

Item no.	Part no	Reference	Description
1	42.00.002		Control pcb
2	1104.0121		Hex nut M4 self locking
3	2039.0326		Spacer for pcb
4	2020.0400		Fixing device for cable harness
5	16.00.232		Dial f. pulse generator
6	3006.0107		Buzzer
7	5110.1028		Gasket poti hot air, core temperature
8	40.00.404		Pulse generator
9	16.00.385		Mounting device f. sealing lip panel insert
10	16.00.386		Sealing lip f. panel insert
11	1306.0218		Washer A4,3

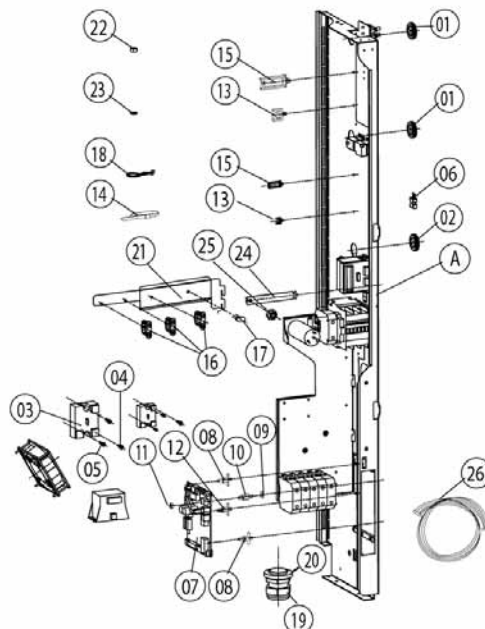

Item no.	Part no	Reference	Description
A	_40.00.410	►2.A	- EM SCC 201/E 3NAC400V50-60 01/04
1	4007.0620		Membrane DGC 29
2	10.00.510		Durchführungsstülle 10/12/16-2
3	40.00.453		Solid state relais
4	10.00.507		- Zylinderschraube 8-32NC,5/16"T20 k=10mm
5	10.00.444		Raised countersunk head screw Torx M4x8
6	42.00.007		External memory
7	40.00.049		Relay-I/O pcb
8	40.00.417		Fixing clip f. pcb
9	1104.0801		Cage nut M4
10	10.00.243		Spacer M4x8
11	1104.0120		Hex nut M4
12	40.01.579		- Platinenhalteclip 61-202 m. Nase 01/04
13	10.00.112		Cable clip short
14	4005.0101		Tie rap 145 mm
15	10.00.111		Cable clip long
16	10.00.417		- Bündelklammer m. Rastplatte klein 1/04
17	10.00.065		Countersunk screw Torx T20 M4x12
18	10.00.471		Cable clip d10-12mm
19	4007.0631		Screwed cable gland M50X1.5(27-35mm)si.gr
20	4007.0634		Fixing nut for cable gland M50
21	40.01.355		Fixing device f. cable guide
22	1106.0160		Hex nut M6
23	1206.0120		Tooth lock washer A6,4
24	40.01.132		- Zugstab f. Tragelement 201/202 01/04
25	1106.0224		Hex nut M6 self locking

Attention! Individual parts shown might not be used in this component group!

► 15* Voltage depending parts shown in chapter 15



SCC 201 E

Valid as of E21SE0404 up to E21SE....

Electrical unit

▶ 2 Electrical installation

2

2 Electrical installation

Voltage 3 NAC 400V 50-60Hz

Item no.	Part no	Reference	Description
26	40.00.471		Bus cable 0.8m
26	40.00.472		Bus cable 1.3m
--	42.00.029		- Memory-Stick SCC 01/04

Attention! Individual parts shown might not be used in this component group!

▶ 15* Voltage depending parts shown in chapter 15

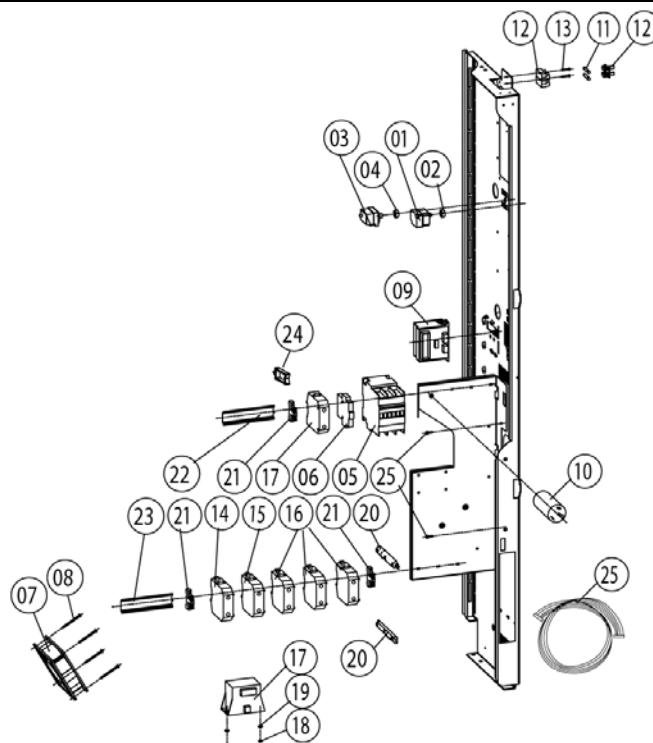

Item no.	Part no	Reference	Description
1	40.01.329		Dry up protector 160°
2	3014.0302		Hex nut M10 for dry-up protector
3	40.00.605		Safety temperature limiter 365°C
4	3014.0327		Hex nut M10x1,0
5	40.01.556		Contacteur CL04A310M6-M
6	40.00.461		- Hilfsschalter BCLL11 01/04
7	40.00.474		Cooling fan D.C.
8	10.00.238		Screw Torx 4x50
9	40.00.277		Control transformer
10	40.00.465		Electronic noise filter
11	4001.0224		Fuse 6.35x32mm
12	4001.1295		Fuse holder e 1003Si/1DS
13	10.00.365		- Zylinderschraube M3x20 Torx
14	4001.1233		Terminal block yellow/green 35mm ²
15	4001.1252		Terminal block, blue 35 mm ²
16	4001.1206		Terminal block 35mm ² grey
16	4001.1206		Terminal block 35mm ² grey
17	40.00.592		Transformer f. cooling fan
18	1105.0120		Hex nut M5
19	1305.0160		Washer A5,3 x 10 mm
20	40.01.272		- Gleitschiene SCC 201/202 01/04
21	4001.1203		End plate for mounting rail
22	2620.370233		Installation rail for Contactor 100mm
23	2620.380129		Installation rail for Contactor 130mm
24	10.00.111		Cable clip long
25	40.00.209		Cable buzzer

Attention! Individual parts shown might not be used in this component group!

► 15* Voltage depending parts shown in chapter 15



SCC 201 E

Valid as of E21SE0404 up to E21SE....

Electrical unit

▶ 2.A - EM SCC 201/E 3NAC400V50-60 01/04

2

2 Electrical installation

Voltage 3 NAC 400V 50-60Hz

Item no.	Part no	Reference	Description
25	40.00.202		Cable CDS sensor
25	40.00.228		Cable control SSR
25	40.00.225		Cable control transformer sec.
25	40.00.238		Cable differential pressure switch
25	40.00.208		Cable humidity control
25	40.00.205		Cable level electrode
25	40.00.226		Cable SC pump
25	40.00.203		Cable solenoid valve
25	40.00.231		Cable transformer for cooling fan sec.
25	10.00.061		Pan head screw Torx T20 M4x12

Attention! Individual parts shown might not be used in this component group!

▶ 15* Voltage depending parts shown in chapter 15

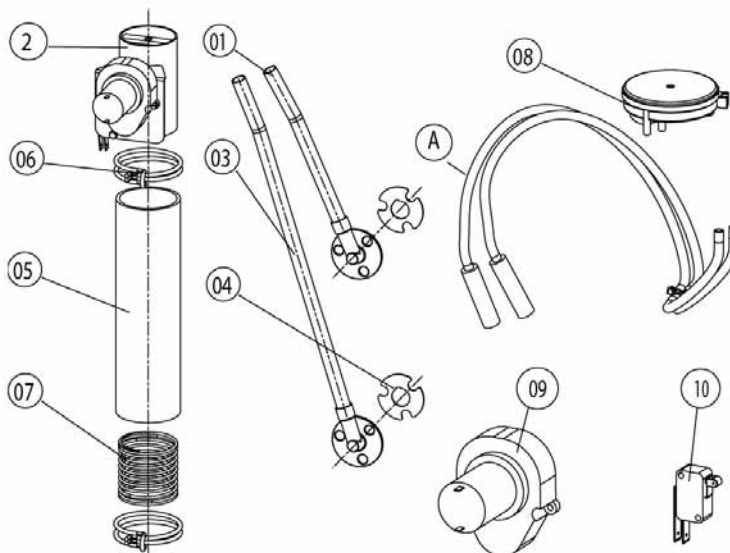

Item no.	Part no	Reference	Description
A	22.00.256	►3.A	Hose set f. humidity control
1	22.00.199		Inner humidity meas. Piece
2	22.00.318		Humidity control cpl. with motor
3	22.00.200		Outer humidity meas. Piece
4	22.00.198		Gasket f. hum. meas. Pipe
5	22.00.214		Hose d50x195
6	2066.0531		Hose clamp ø56
7	2001.0124		Compression spring
8	3017.1011		Pressure sensor for humidity control
9	3101.1010		Humidity control motor
10	3016.0102		Micro switch

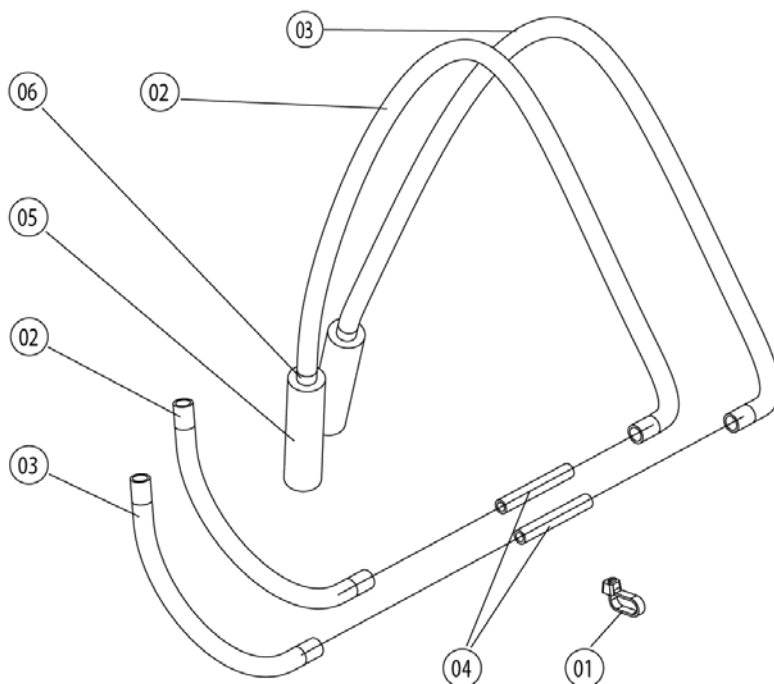

Item no.	Part no	Reference	Description
1	4005.0101		Tie rap 145 mm
2	2110.1020		Silicon hose $\varnothing 5 \times 1.5$ blue
3	2110.1019		Silicone hose $\varnothing 5 \times 1,5$ "red"
4	1900.0203		Ceramic tube $8 \times 5 \times 60$ mm for
5	2112.1338		Silicone hose $\varnothing 8 \times 2 \times 20$
6	2110.1008		Silicon hose $\varnothing 10 \times 2$ mm

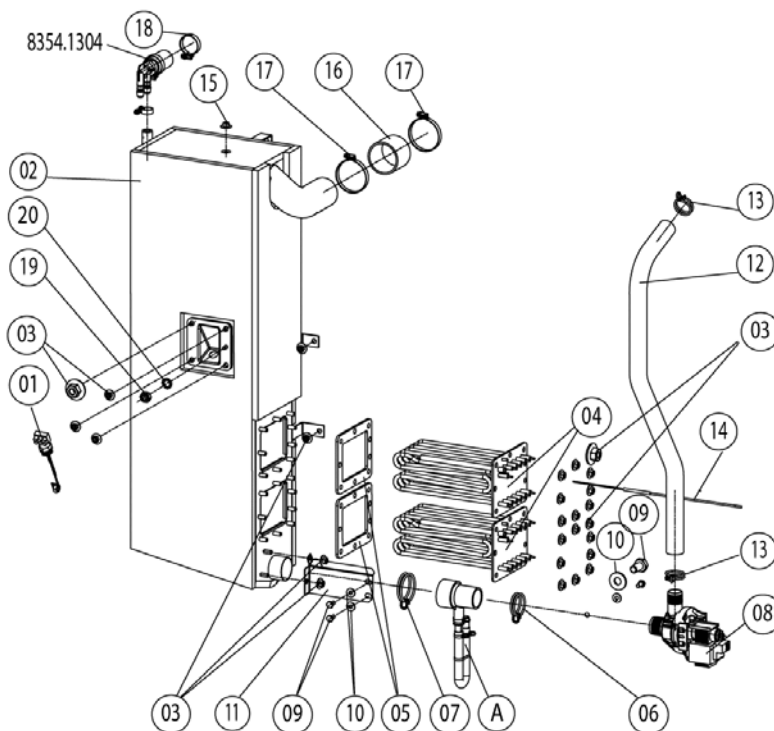

Item no.	Part no	Reference	Description
A	_8354.1320	►4.A	Pump connection
1	3002.0402		Filling level electrode 90 mm
2	44.00.174		Steam generator insolated
3	1106.0803		Hex combination nut M6 galv
4	44.00.195		Heating element
5	44.00.279		Gasket f. heating element
6	2066.0519		Hose clamp 35,6mm
7	2066.0526		Hose clamp ø46mm
8	44.00.207		Emptying pump
9	1006.0762		Hex screw M6x10
10	1306.0222		Washer A6.4x15x1.5
11	44.00.232		Fixing device f. pump steam generator
12	44.00.233		Drain hose steam generator
13	2066.0518		Hose clamp 30mm
14	40.00.291		Thermocouple steam generator
15	1104.0122		Hex combination nut M4 galv
16	2112.1006		Steam hose 50x7mm
17	2066.0504		Hose clamp 40-60mm
18	2066.0506		Hose clamp 20-32mm
19	1105.0120		Hex nut M5
20	1205.0120		Tooth lock washer A5,3

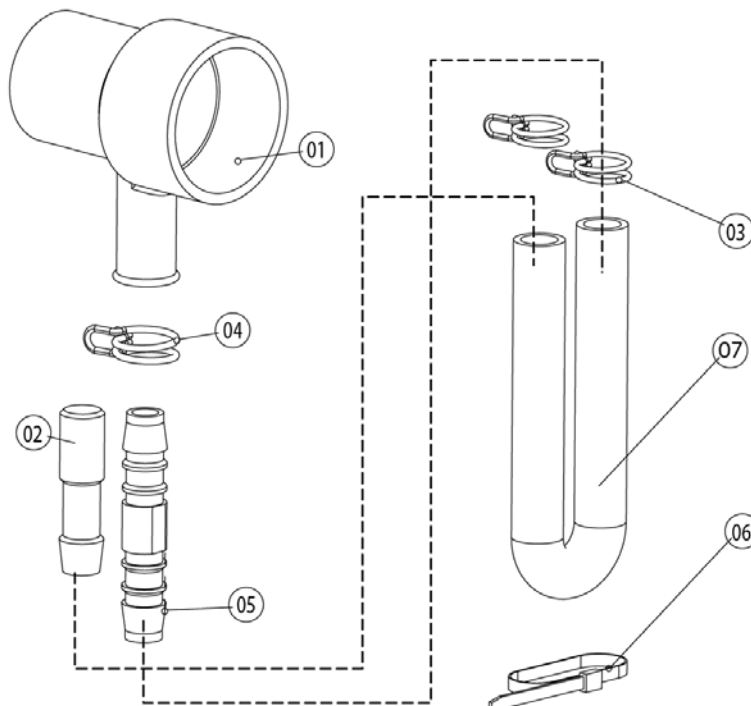

Item no.	Part no	Reference	Description
1	2118.1000		Pump connection spout
2	2120.1259		Stop plug 10mm
3	2066.0527		Hose clamp \varnothing 14mm
4	2066.0530		Hose clamp \varnothing 16.4mm
5	2062.0331		Junction pressure hose GS 10
6	4005.0101		Tie rap 145 mm
7	2110.1008		Silicon hose \varnothing 10x2mm

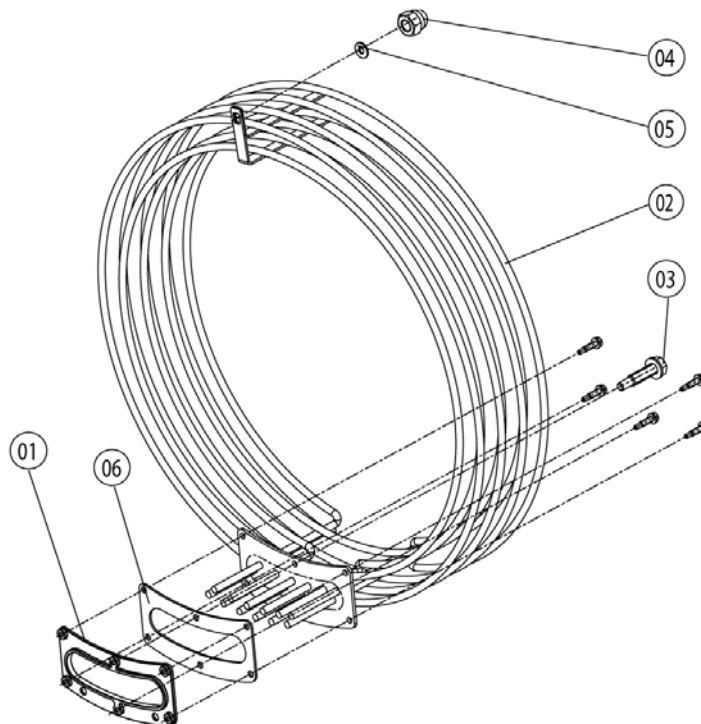

Item no.	Part no	Reference	Description
1	40.00.305		Mating flange f. heating assembly
2	40.00.597		- Heizkoerper 201 230V unten 01/04
3	10.00.109		Hex screw M5x23
4	1106.0360		Cap nut M6, high shape
5	1306.0222		Washer A6.4x15x1.5
6	40.00.332		Gasket f. heating assembly

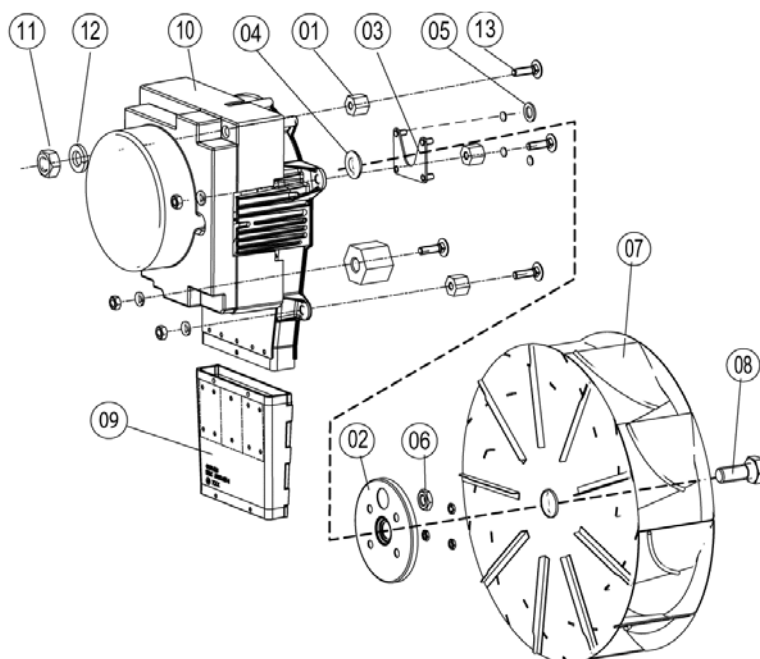

Item no.	Part no	Reference	Description
1	2120.1306		Spacer SW19x17
2	22.00.123		Flange f. motor shaft gasket
3	22.00.120		Mounting support f. gasket flange
4	22.00.083		Motor shaft gasket
5	1315.0101		Copper washer 6x10
6	1106.0220		Hex nut M6 flat
7	22.00.188		Fan wheel d340x110
8	1008.0763		Hex screw M8x20
9	40.00.435		Exhaust channel f. SSR
10	40.00.274		Fan motor
11	1108.0260		Hex nut M8
12	1208.0260		Spring washer B8
13	1008.1005		Square necked mushroom head bolt 8x40

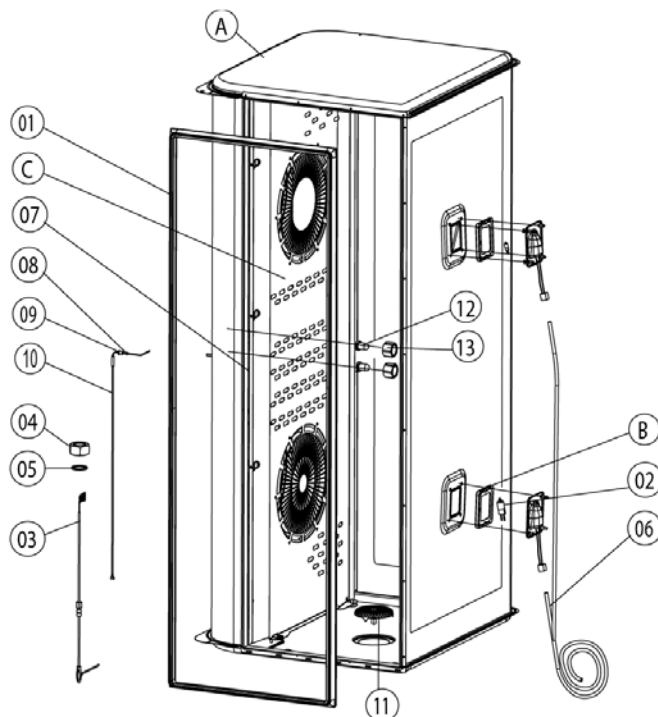

Item no.	Part no	Reference	Description
A	_20.00.144	►7.A	Interior cabinet welded
B	40.00.091	►7.B	Gasket frame w. glass a. gaskets
C	22.00.384	►7.C	Air baffle
1	20.00.398		Door gasket
2	3024.0201		Halogen bulb for interior cabinet
3	40.00.295		Meat probe sensor
4	10.00.422		Hex nut M16
5	1315.0104		Copper washer 16x20x1,5
6	40.00.224		Wiring interior light
7	22.00.220		Air baffle support
8	3014.0162		Sealing cone for thermocouple
9	3014.0163		Gasket sleeve with nipple
10	40.00.594		Thermocouple interior cabinet B1
11	2005.0308		Outlet sieve
12	50.00.395		Nozzle f. moistening
13	50.00.394		Union nut M12x12

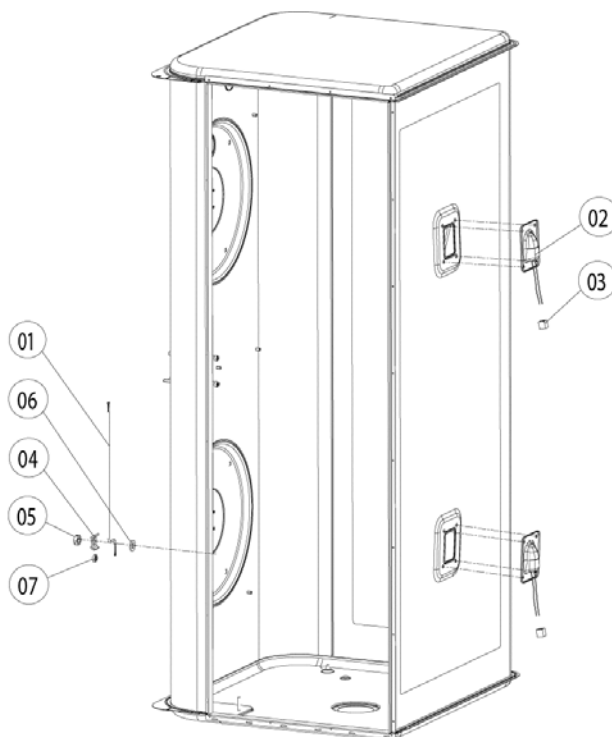

Item no.	Part no	Reference	Description
1	40.00.399		Thermocouple humidity
2	40.00.098		Reflector f. interior light
3	4001.1248		Porcelain connector 2-pin interior light
4	1330.0100		Clamp strap f. sensor
5	1106.0224		Hex nut M6 self locking
6	1306.0120		Washer A6,4
7	10.00.100		Hex nut M4, self-locking

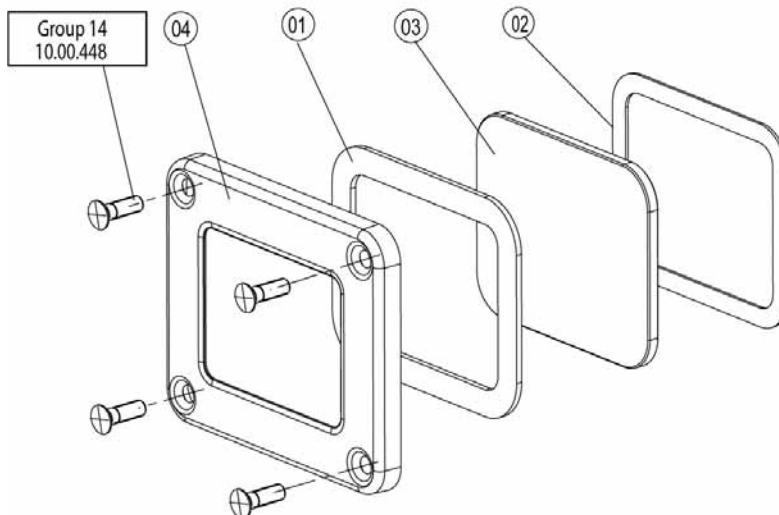

Item no.	Part no	Reference	Description
1	40.00.093		Outer gasket f. interior light
2	40.00.094		Inner gasket f. interior light
3	40.00.095		Glass pane f. interior light
4	40.00.096		Gasket frame f. interior light

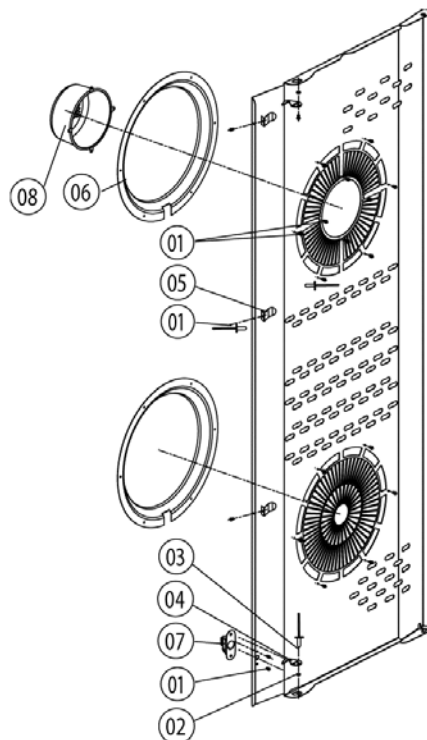

Item no.	Part no	Reference	Description
1	40.01.289		Fixing clip core temp. cable
2	1304.0160		Washer A4,3
3	1604.0167		Rivet 4x10
4	22.00.332		Air sucking ring f. air baffle
5	2760.1370		Latch hook for air baffle
6	1603.0168		Rivet 3,2x8 A4
7	22.00.361		Deep-draw f. air baffle

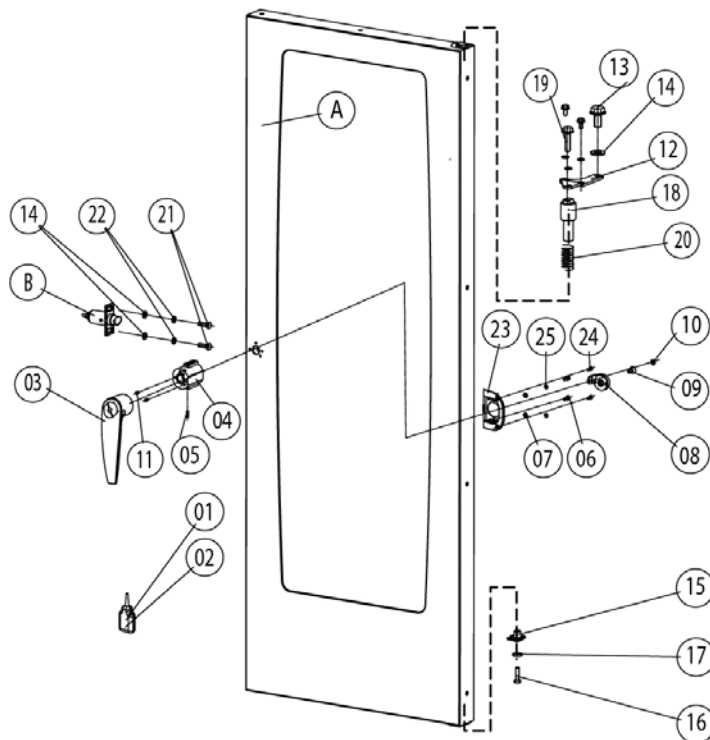

Item no.	Part no	Reference	Description
A	24.00.121	►8.A	Door
B	8514.1307	►8.B	Door catch
1	2001.0042		Loctite 243 10 ml
2	2001.0046		Loctite 272
3	24.00.136		Door handle
4	8474.1410		Door lock
5	1005.1901		Straight pin $\varnothing 5,6 \times 16$
6	1006.0761		Hex screw M6x12
7	1206.0261		Spring washer B6
8	2940.1305		Door bolt
9	1008.1963		Hex socket countersunk head screw M8x16
10	2039.0309		Cover cap for door
11	1004.0665		Allen screw M4x6
12	24.00.133		Door mounting support top
13	1008.0768		Ornamental screw M8x16
14	1308.0160		Washer A8,4
15	24.00.145		Door bolt
16	1008.0766		Hex screw M8x30
17	1308.0162		Washer A8.4
18	24.00.048		Door bolt
19	1008.0769		Ornamental screw M8x30
20	2001.0109		Compression spring
21	1008.0761		Hex screw M8x25
22	1208.0260		Spring washer B8
23	24.00.216		Mounting bracket f. door lock
24	1008.0752		Hex screw M5x10

Attention! Individual parts shown might not be used in this component group!

► 15* Voltage depending parts shown in chapter 15



SCC 201 E

Valid as of **E21SE0404** up to **E21SE....**

Electrical unit

▶ **8 Door**

8

8 Door

Voltage **3 NAC 400V 50-60Hz**

Item no.	Part no	Reference	Description
25	1305.0160		Washer A5,3 x 10 mm

Attention! Individual parts shown might not be used in this component group!

▶ 15* Voltage depending parts shown in chapter 15

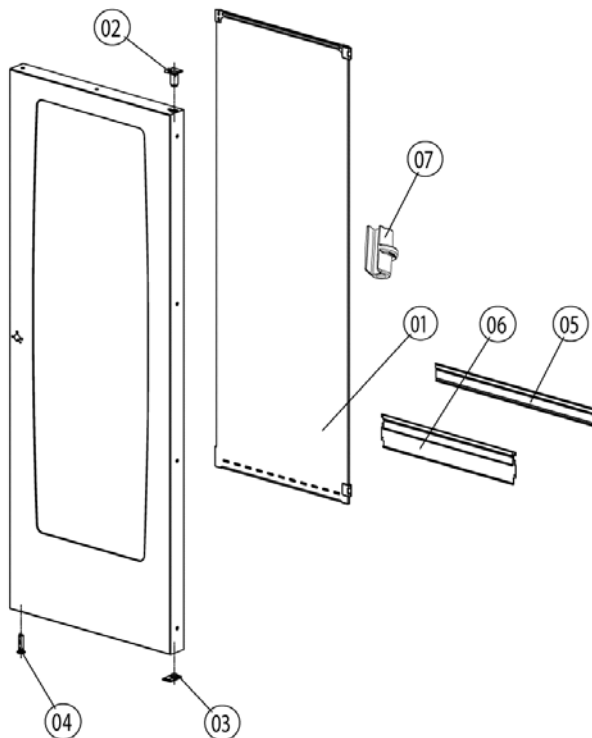

Item no.	Part no	Reference	Description
1	24.00.210		Inner glass pane
2	24.00.147		Sleeve for door bolt top
3	24.00.159		Door setting bolt
4	24.00.503		Fixing device f. magnet
5	24.00.187		Gasket glass pane/trolley
6	24.00.177		Pre heat mechanism f. door
7	24.00.507		Scheibehalter mitte

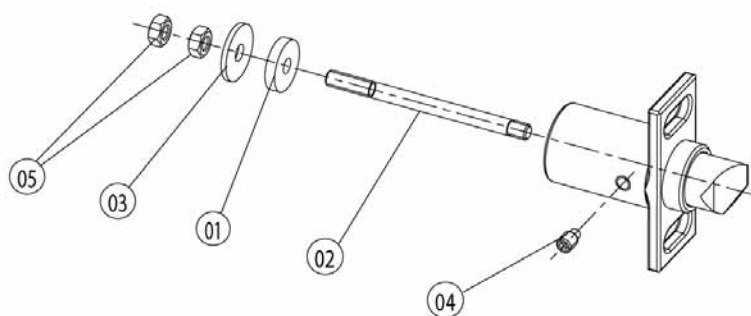

Item no.	Part no	Reference	Description
1	5012.0711		Silicone plate for door
2	1006.1000		Stud bolt M6x75
3	1306.0550		Washer A6,6
4	1004.0904		Hex socket set screw M6x10
5	1106.0160		Hex nut M6

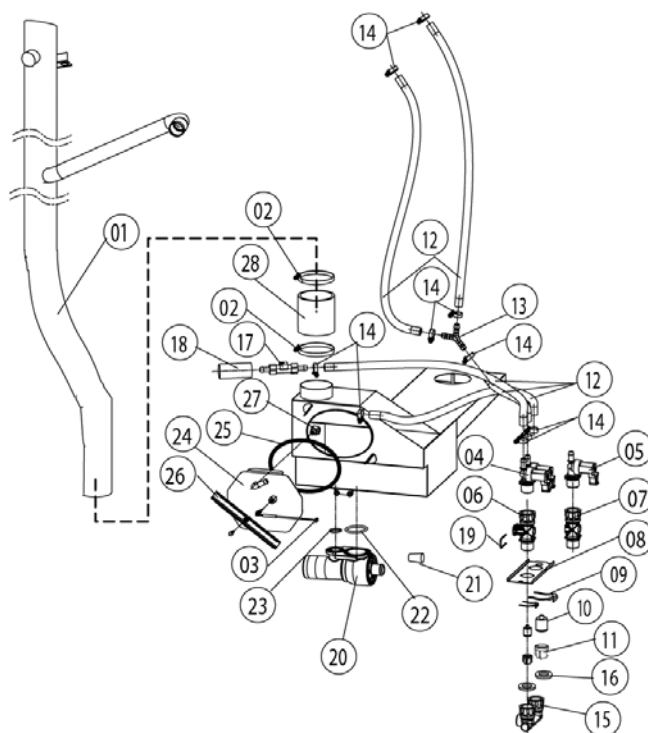

Item no.	Part no	Reference	Description
1	54.00.208		Exhaust pipe
2	2066.0516		Hose clamp 60-80 mm
3	40.00.398		Thermocouple quenching
4	50.00.138		Double solenoid valve
5	50.00.139		Single solenoid valve
6	50.00.072		Water distribution vert roll guide con.
7	50.00.073		Water distribution vert w/o roll guide con.
8	50.00.275		Mounting device f. water distribution
9	50.00.086		Locking plate f. water distribution
10	50.00.078		Non return valve DW16/DN12
11	1900.0202		Water filter
12	2067.0050		Pressure hose d10mm
13	2062.0303		Y-filting YS10
14	2066.0205		Hose clamp 8-16x9 mm SW 7mm
15	8664.1301		T-fitting water connection
16	5110.1024		Gasket for G3/4" threaded joint
17	44.00.211		Water volume sensor
18	2112.1346		Protecting hose ø28x2x70mm
19	50.00.085		Plug-in spring f. hand shower roll guide
20	54.00.357		Ball valve drain SCC cpl.
21	10.00.369		Plug cone shaped
22	10.00.511		O-Ring f. Kugelhahn 46x3.5
23	10.00.512		O-Ring f. Kugelhahn 26x3.5
24	54.00.237		Inspection lid f. quenching chamber
25	5012.0566		Gasket quenching chamber 0-ring
26	54.00.225		Clamping bar

Attention! Individual parts shown might not be used in this component group!

► 15* Voltage depending parts shown in chapter 15



SCC 201 E

Valid as of E21SE0404 up to E21SE....

Electrical unit

▶ 9 Water supply, quenching box

9

9 Water supply, quenching
box

Voltage 3 NAC 400V 50-60Hz

Item no.	Part no	Reference	Description
27	2016.0943		Quenching nozzle
28	2112.1307		Steam hose 70x5mm

Attention! Individual parts shown might not be used in this component group!

▶ 15* Voltage depending parts shown in chapter 15

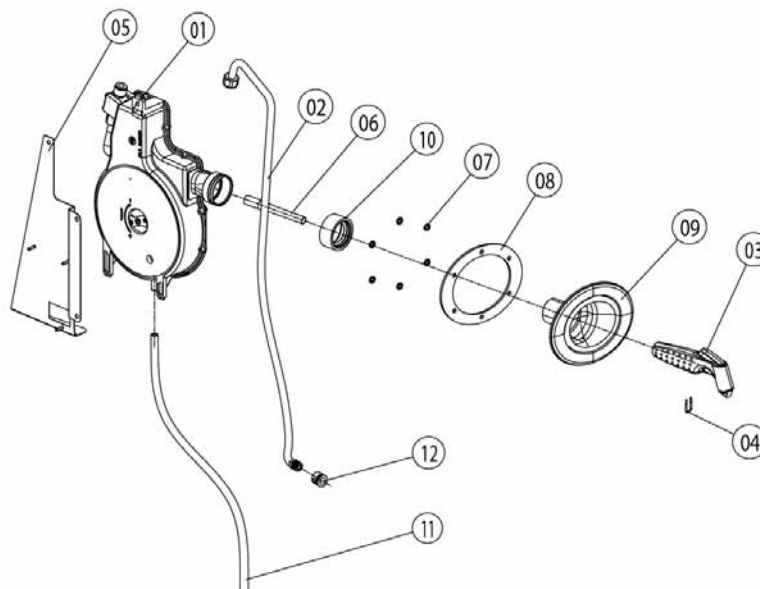

Item no.	Part no	Reference	Description
1	50.00.176		Hand shower roll guide
2	50.00.230		Connect. pipe f. hand shower roll guide
3	50.00.130		Hand shower
4	50.00.156		Clamp f. hand shower roll guide
5	50.00.544		- Halterung ges. f.SR 201/202 01/04
6	50.00.548		Hose $\varnothing 10 \times 2 \times 500$ f. hand shower
7	1107.0100		Star lock d4
8	50.00.290		Gasket f. tulip
9	50.00.135		Tulip for handshower
10	50.00.297		Gasket f. tulip
11	2110.1008		Silicon hose $\varnothing 10 \times 2$ mm
12	2069.0107		Non return valve DN6 steam generator

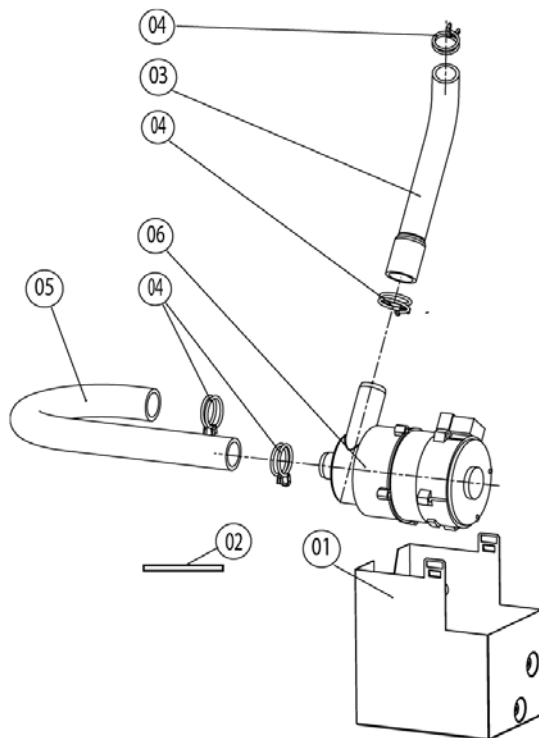

Item no.	Part no	Reference	Description
1	12.00.245		Housing f. Cleaning pump
2	10.00.091		Rubber profile f. edge protection
3	56.00.175		Pressure hose f. cleaning
4	2066.0521		Hose clamp 27mm
5	56.00.176		Suction hose f. cleaning
6	56.00.178		Pump f. cleaning UP30

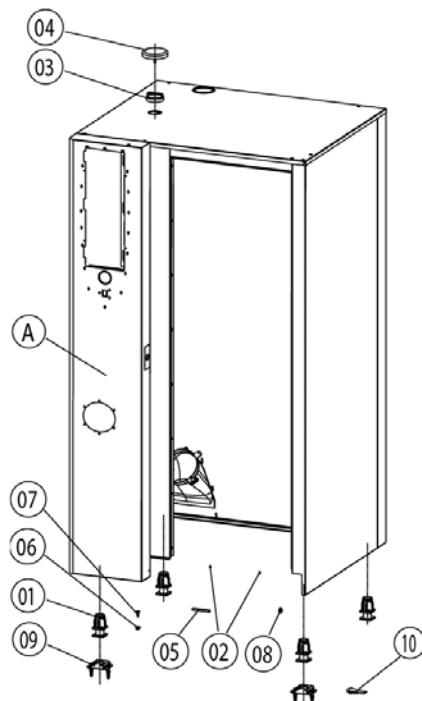

Item no.	Part no	Reference	Description
A	_16.00.170	►13.A	- P-Außenkasten CPC 201/E 01/04
1	2039.0111		Foot adjustable, metal, 40 x 40
2	1603.0161		Rivet 3,2x6
3	8450.1310		Spacer ring
4	8455.1209		Vent cover
5	5013.0100		Edge protection profile
6	1106.0802		Cage nut M6
7	1006.0760		Hex screw M6x16
8	2022.0101		Grommet 18 mm
9	8700.0317		Floor fixing set
10	5006.0213		Glue for floor fixing brackets

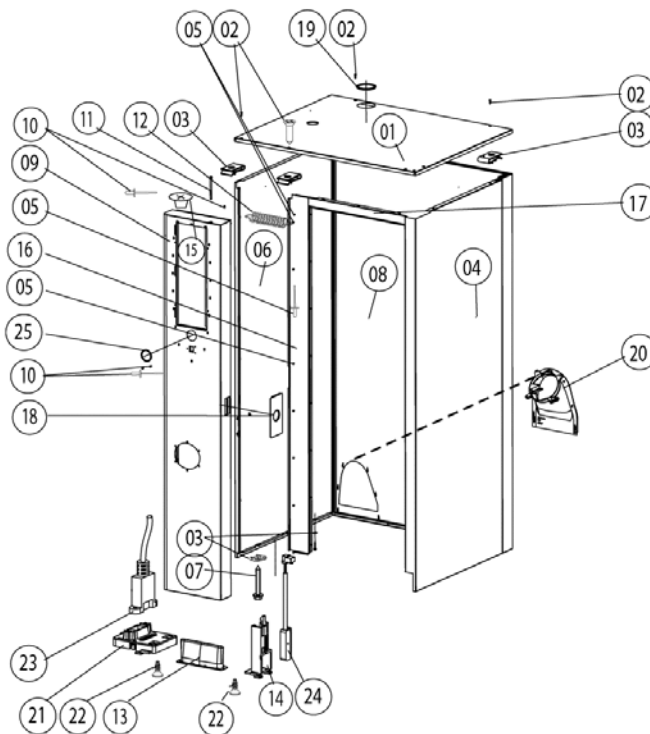

Item no.	Part no	Reference	Description
1	16.00.337		Top cover
2	1003.2265		Countersunk self tapping screw 4,2x16
3	1104.0820		Snap nut 4.2mm
4	16.00.142		Side panel right
5	1603.0166		Rivet 3.2x7,9, CNS closed
6	16.00.143		Side panel left
7	10.00.102		Hex self tapping screw 4,2x32
8	16.00.195		Back panel
9	16.00.296		Front panel
10	1603.0161		Rivet 3,2x6
11	10.00.069		Slotted pan head screw M6x90
12	2002.0107		Tension spring for front panel
13	16.00.673		Air inlet filter
14	16.00.384		Bracket for door contact switch
15	2039.0331		Cap for service door
16	16.00.358		Crossbar front panel
17	16.00.330		Crossbar top
18	16.00.115		Rosette
19	5105.1028		Gasket f. breather tube d=74mm
20	40.00.476		Exhaust channel
21	16.00.329		Cover f. USB interface
22	10.00.103		EJOT PT-screw KA 3.5x10
23	40.00.470		Interface cable USB 1.5m
24	40.00.335		Door switch
25	16.00.338		Edge protection profile

Attention! Individual parts shown might not be used in this component group!

► 15* Voltage depending parts shown in chapter 15

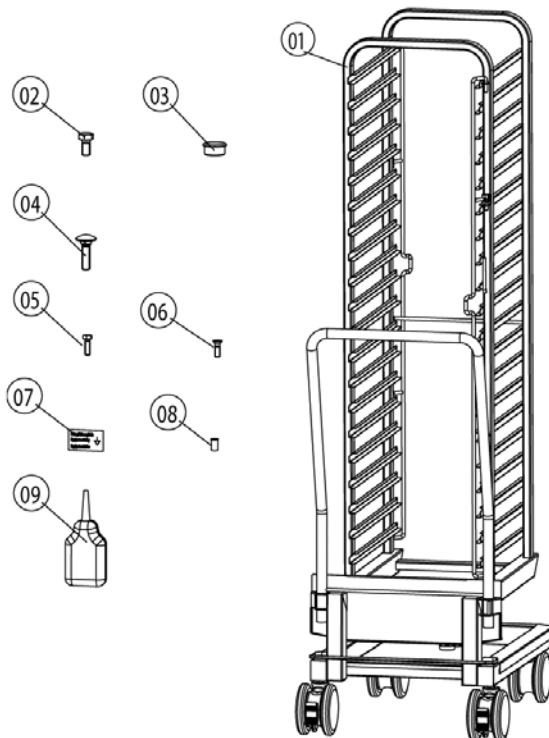

Item no.	Part no	Reference	Description
1	60.21.054		Mobile oven rack
2	1008.0760		Hex screw M8x16
3	10.00.357		Rubber plug black
4	10.00.448		Phillips countersunk-head screw M5x16
5	1008.0750		Hex screw M5x16
6	1004.0666		Hex screw M4x10
7	2049.0817		Sticker, Equipotential bonding
8	1104.0400		Rivet nut M4
9	5006.0202		Loctite IS 495



SCC 201 E

Valid as of up to

Electrical unit

▶ **15 Voltage depending parts**

0

0 Voltage depending parts

Voltage **3 NAC 400V 50-60Hz**

Item no.	Part no	Reference	Description
----------	---------	-----------	-------------

Attention! Individual parts shown might not be used in this component group!

▶ 15* Voltage depending parts shown in chapter 15



xxxx

0 xxxx

0

Elektrogeräte

▶ **0 xxxx**

0

Gültig von
xxxx

bis:
xxxx

Spannung: **xxxx**

Attention! Individual parts shown might not be used in this component group!

▶ 15* Voltage depending parts shown in chapter 15