

DIAL CONTROL

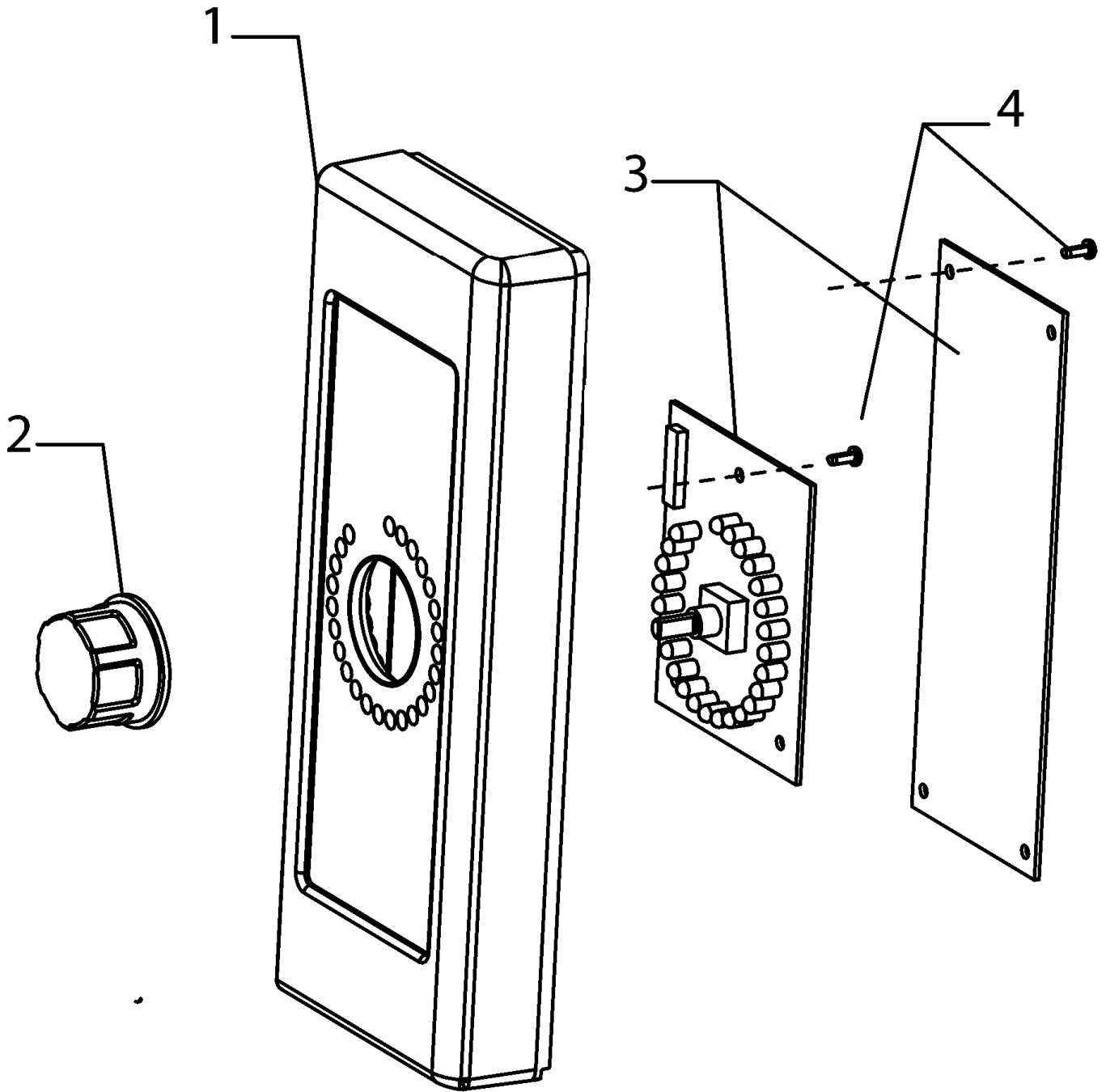

DOOR

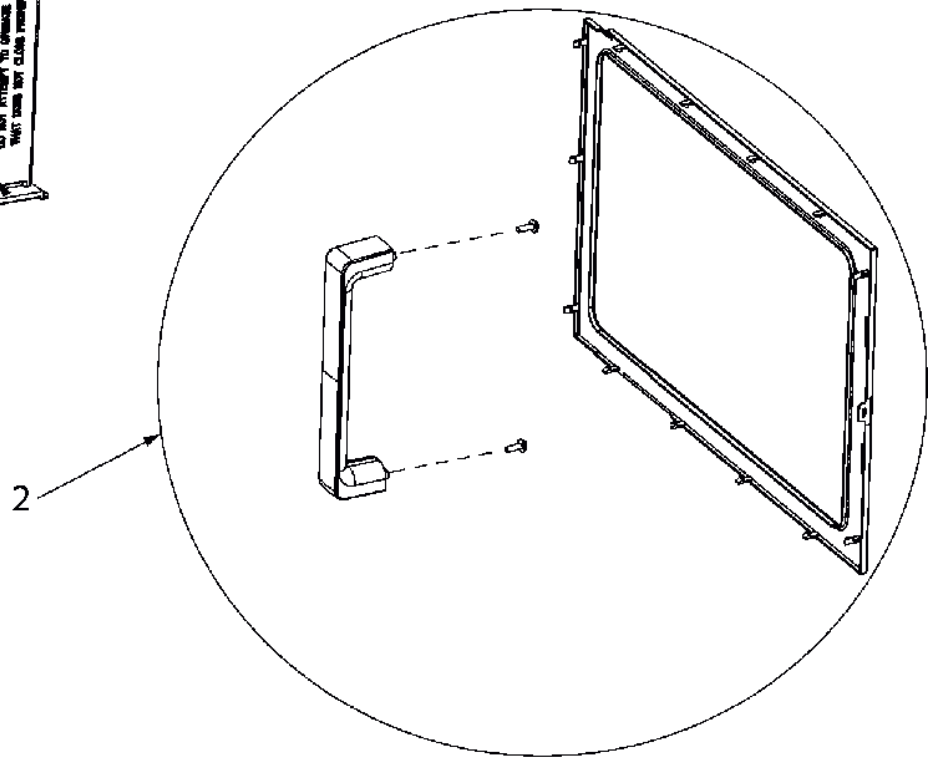
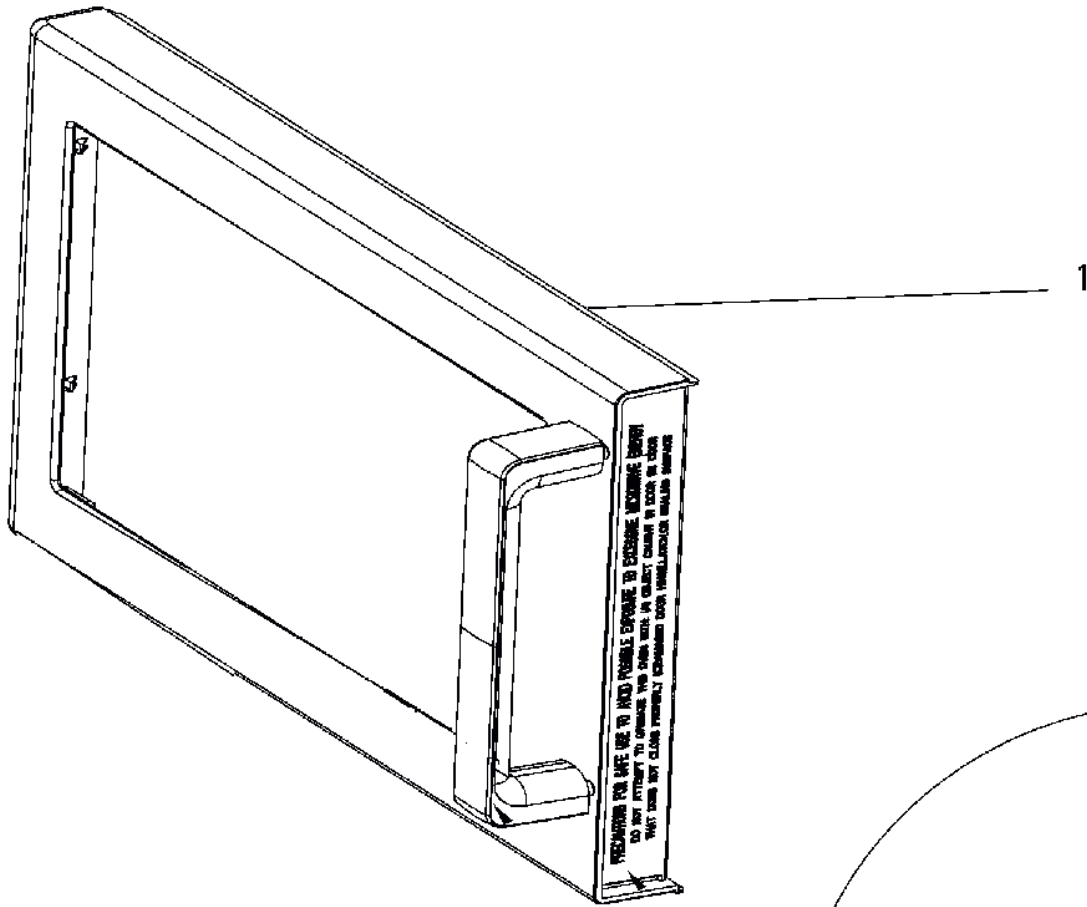

OVEN CAVITY

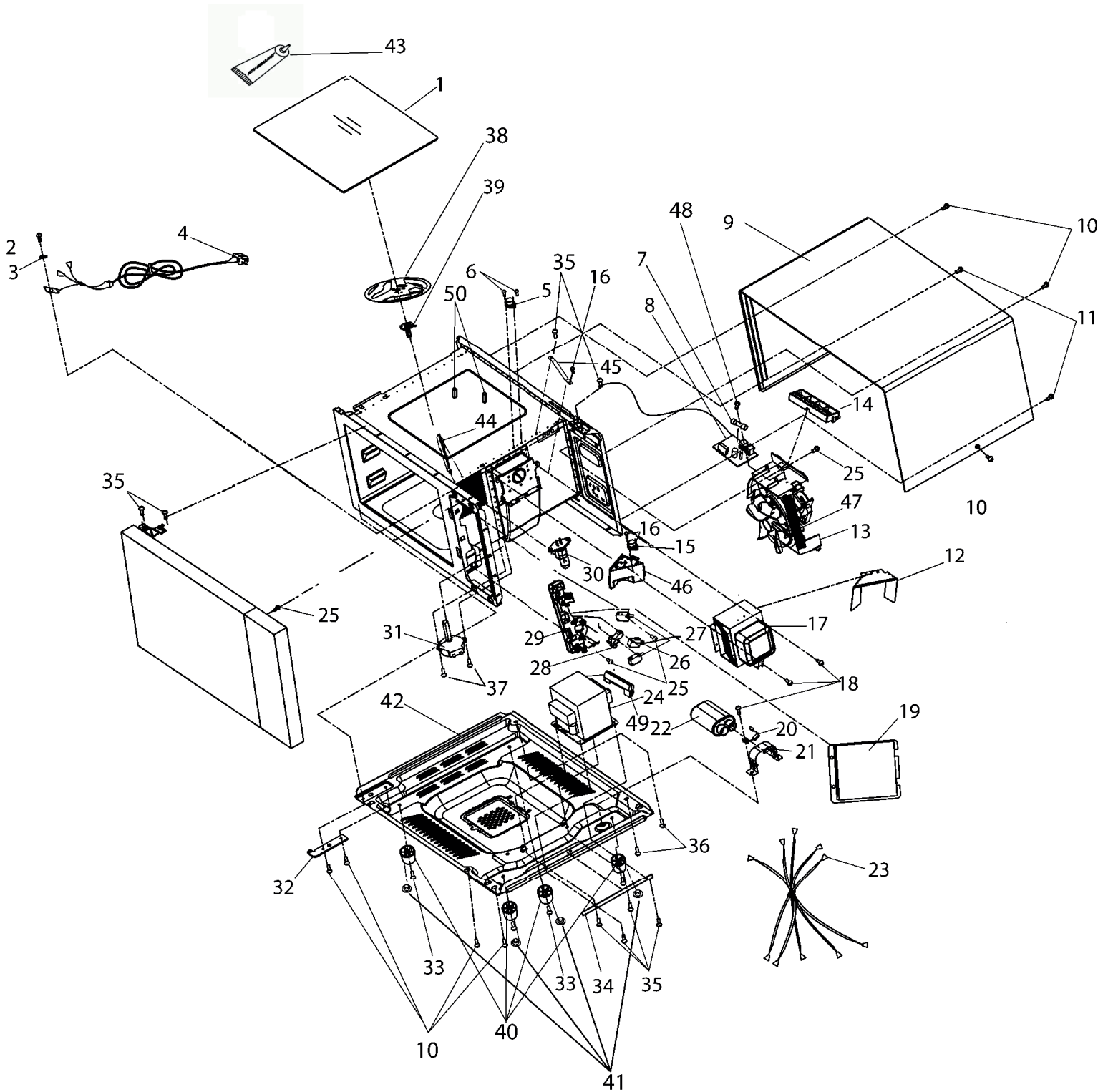

Seite	Pos	Kredtor Artikel Nr.	GB
001	001	58101005	CONTROL PANEL ASSY
001	002	58101007	KNOB
001	003	58101010	BOARD, HV/LV
001	004	58101041	SCREW
002	001	58101013	DOOR ASSY, MENUMASTER
002	002	14128072	KIT, DOOR HANDLE
003	001	58101001	TRAY, CERAMIC
003	002	58101047	SCREW
003	003	58101051	WASHER, LOCK
003	004	58101027	POWER CORD
003	005	58101030	THERMAL CUTOUT, CAVITY
003	006	58101041	SCREW
003	007	20034004	FUSE-10A TDM
003	008	58101022	FUSE BLOCK / FILTER ASSY
003	009	58101059	WRAPPER
003	010	58101044	SCREW
003	011	58101068	SCREW-TX
003	012	58101040	DEFLECTOR
003	013	58101056	BLOWER MOTOR ASSY
003	014	58101033	SPACER
003	015	58101032	THERMAL CUTOUT, MAG
003	016	58101041	SCREW
003	017	53002004	MAGNETRON
003	018	58101047	SCREW
003	019	58101060	GUIDE, AIR- RIGHT
003	020	58101020	DIODE
003	021	58101057	BRACKET, CAPACITOR
003	022	58101019	CAPACITOR, 1.1
003	023	58101037	HARNESS, MAIN
003	024	58101017	TRANSFORMER, HV
003	025	58101045	SCREW
003	026	59002157	SWITCH, MONITOR
003	027	56001036	SWITCH, INTERLOCK- PRIMARY
003	028	58101035	LEVER
003	029	58101034	BRACKET, SWITCH
003	030	58101024	LAMP
003	031	58101053	MOTOR, ANTENNA
003	032	58101066	BRACKET, HINGE
003	033	58101043	SCREW
003	034	59004077	GASKET, PER FT
003	035	58101047	SCREW
003	036	58101044	SCREW
003	037	58101050	SCREW
003	038	58101058	BLADE, STIRRER
003	039	58101054	SHAFT, STIRRER
003	040	58101003	FOOT
003	041	58101004	PLUG, FOOT
003	042	58101002	BASEPAN
003	043	59002167	SEALER
003	044	58101039	BRACKET, SUPPORT
003	045	58101067	BRACKET, SUPPORT - MAG
003	046	58101038	DUCT, AIR
003	047	A3030374	GASKET
003	048	58101049	SCREW
003	049	58101028	FUSE, HV
003	050	58101069	SPACER

WIRING DIAGRAM

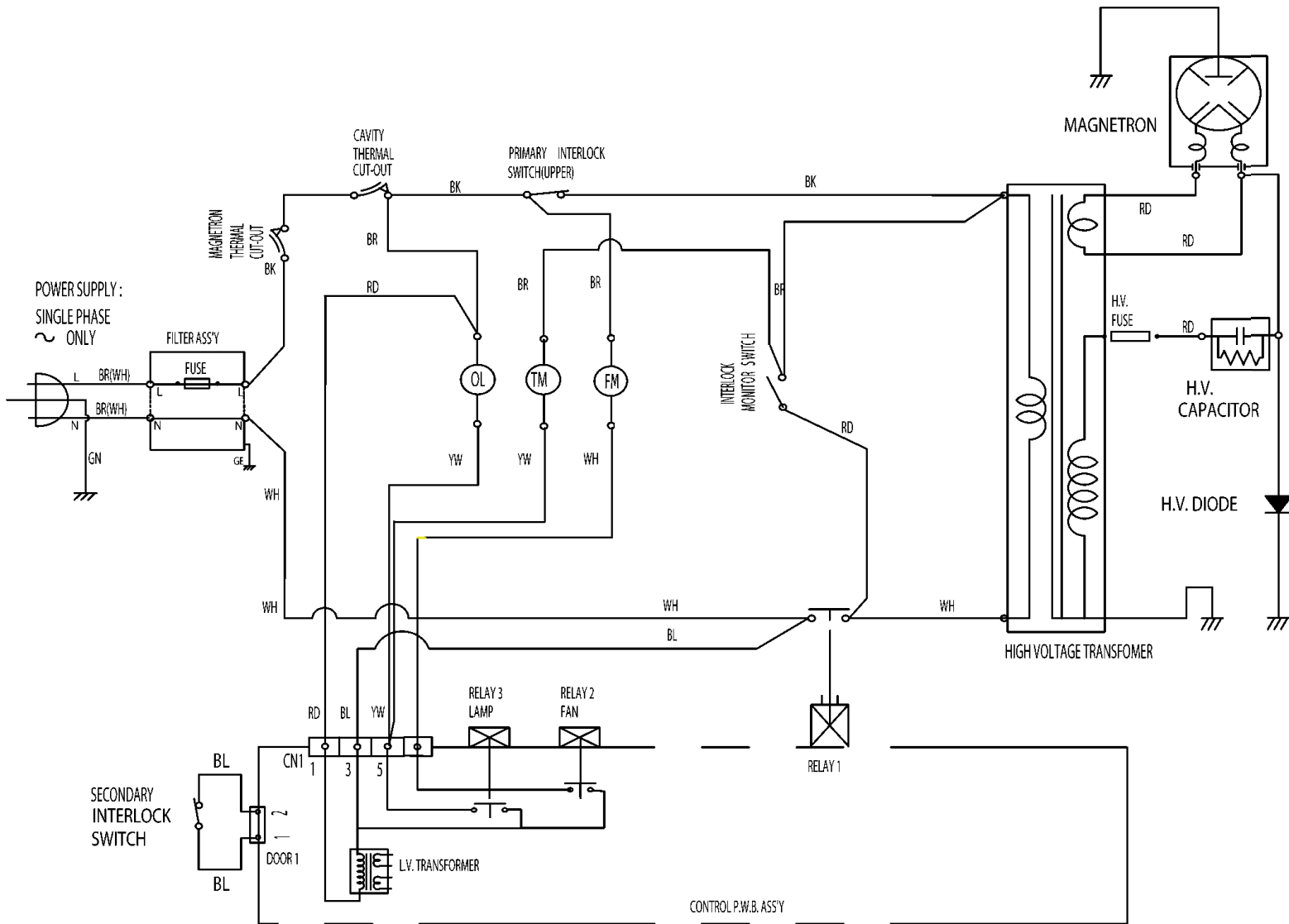

[CONDITION]
DOOR : CLOSED
COOK : OFF

NOTE :
 (OL) : OVEN LAMP
 (FM) : FAN MOTOR
 (TM) : TRAY MOTOR

BK : BLACK
 RD : RED
 WH : WHITE
 YW : YELLOW

BL : BLUE
 BR : BROWN
 GN : GREEN
 GE : YELLOW/GREEN