

1

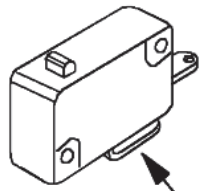

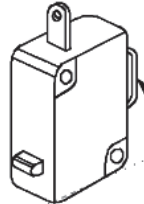

Seite	Pos	Kreditor Artikel Nr.	GB
001	001	59001193	NLA- BASE PLATE
001	002	53001169	LEG
001	003	59001187	TRANSFORMER, HV 120V 60HZ 15A
001	004	R0131029	SCREW,TAP TITE(S)-BINDING HEAD
001	005	R0654125	NLA- SCREW, TAP TITE
001	006	R0131246	SCREW, TAPPING TRUSS HEAD
002	001	59001180	NLA- PANEL, CONTROL
002	002	R9800357	NLA- LEVER, RELEASE
002	003	R9800320	SPRING
002	004	59001181	BUTTON
002	005	59001182	NLA- KNOB
002	006	59001191	TIMER
002	007	R9800691	NLA- SCREW, SPECIAL D
002	008	R0654183	SCREW, TRUSS HD
003	001	R9800273	COVER, CHOKE
003	002	R9800284	NLA- LATCH
003	003	R9800283	SPRING
003	004	R9900077	CAP, TOP HINGE
003	005	59001176	OUTER DOOR ASSY
003	006	59001177	NLA- DOOR FRAME CHOKE ASSY
004	001	R0131325	CAPACITOR, 1.0
004	002	R0131110	FUSE
004	003	R0131269	NLA- BRACKET, CAPACITOR
004	004	R9900073	NLA- SHROUD, FAN MOTOR
004	005	R9900079	NLA- DUCT, AIR
004	006	R9800458	BLADE, FAN
004	007	R9900082	MAGNETRON
004	007	53002004	MAGNETRON
004	008	R9900083	POWER CORD
004	009	R9900051	MOTOR, FAN
004	010	59001188	HARNESS, WIRE
004	011	R9900095	LAMP
004	012	59001189	THERMAL CUTOUT, CAVITY
004	013	R9800486	DIODE
004	014	R9900097	THERMAL CUTOUT, MAG
004	015	R9800440	HOLDER, WIRING
004	016	R9800472	NLA- FUSE BLOCK/NOISE FILTER
004	017	R9800442	CHOKE FILTER ASSY
004	018	59001192	NLA- COVER, POWER CORD
004	019	59001185	NLA- INSULATOR
004	020	R0131029	SCREW,TAP TITE(S)-BINDING HEAD
004	021	R9800691	NLA- SCREW, SPECIAL D
004	022	R0654183	SCREW, TRUSS HD
004	023	R9800411	NLA- SCREW, TAP TH
004	024	R0131280	NLA- SCREW
004	025	R0654030	SCREW, PAN HD S/TAP
005	001	R9900057	BRACKET, SWITCH
005	002	R9900519	SWITCH
005	003	R9900520	SWITCH, MONITOR
005	004	R9800691	NLA- SCREW, SPECIAL D
006	001	59001183	WRAPPER
006	002	59001184	RIVET ASSY
006	003	59001186	MOTOR, ANTENNA 120V 60HZ
006	004	59001190	ANTENNA ASSY
006	005	R9900074	NLA- GUIDE, AIR (LEFT)
006	006	R9900075	GUIDE, AIR (RIGHT)
006	007	59001194	TRAY, CERAMIC
006	008	R0131246	SCREW, TAPPING TRUSS HEAD
006	009	R9900539	NLA- SCREW, TRUSS HD
006	010	R0654180	SCREW, PAN HD
006	011	59001195	NLA- SCREW
		16022123	SVC MAN, COMM MICROWAVE

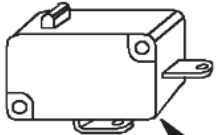
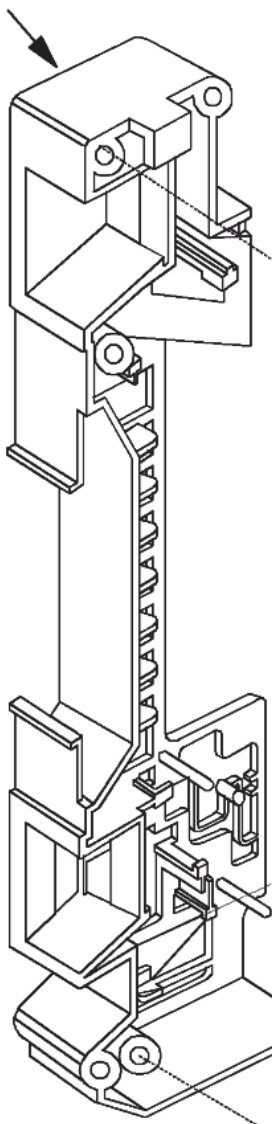
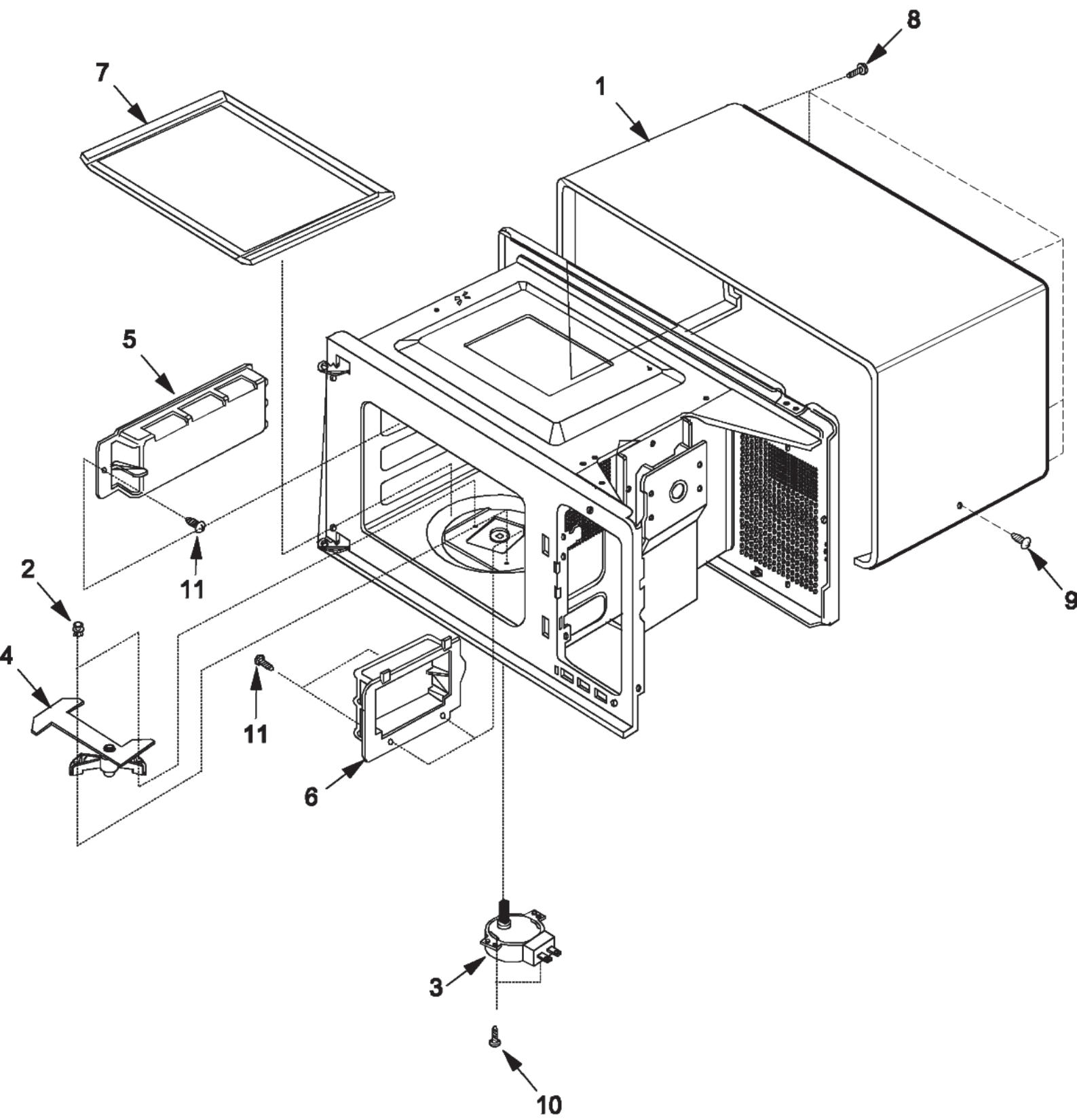