

WAREWASHER

ELECTRONICAL SWITCHES
SIMPLE BODY VERSION
LOWER AND UPPER VERSION

TYPE: 18ER

Accessories
BOOSTER PUMP
DVGW
DETERGENT DISPENSER
DRAIN PUMP

Spare Parts Manual

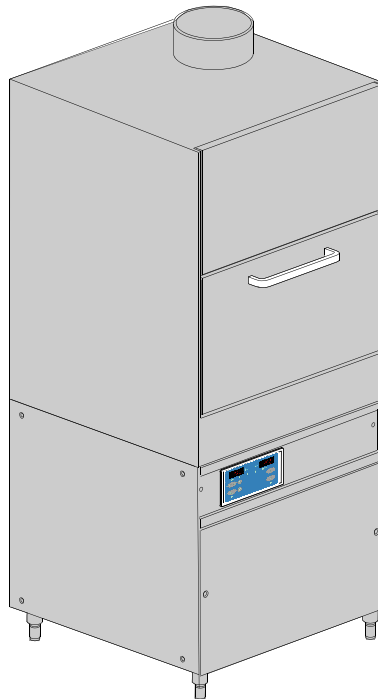

INFORMAZIONI GENERALI

Questo catalogo serve per richiedere con esattezza le parti di ricambio

Nelle ordinazioni indicare:

1) il numero dei codici dei particolari seguito dalla descrizione e la quantità desiderata;

2) Il codice alfa-numerico presente nella seconda colonna della tabella ;

I disegni delle parti di ricambio sono solo indicativi e non rappresentano il pezzo in oggetto.

I dati contenuti in questo catalogo sono indicativi e possono essere soggetti a modifiche senza impegno di preavviso.

ALLGEMEINE INFORMATIONEN

Dieser Ersatzteilkatalog dient zur genauen Angabe der Teile bei Ersatzteilbestellungen.

Bei Ersatzbestellung ist folgendes anzugeben:

1) Die Bestellnummer der Ersatzteile mit der entsprechenden Beschreibung genaue Menge;

2) Der alpha-numerischer Code auf der zweiten Reihe in dein Spalte;

Die Zeichnungen der Ersatzteile sind nur als Hinweise gedacht und stellen nicht das betroffene Teil dar.

Bei den im Katalog angeführten Daten handelt es sich um Anhaltsdaten, die jederzeit, ohne Vorankündigung, geändert werden können.

GENERAL INFORMATION

The present spare parts order exactly the right spare parts

When ordering specify:

1) the part's code number followed by its description and quantity needed;

2) The alpha-numeric code is in the second column in the chart;

Spare parts drawings are general and do not represent the part.

The contents of this catalogue are general and can undergo changes without prior notice.

INFORMACIONES GENERALES

El presente catálogo sirve para pedir con exactitud las partes de repuesto

En los pedidos se debe indicar:

1) el número de código de la parte y a continuación la descripción cantidad deseada;

2) El código alfanumerico presente en la signada columna de la tabla;

Los diseños de las partes de recambio son solo indicativos y no representan la pieza en cuestión.

Los datos contenidos en el presente catálogo son indicativos y pueden modificarse sin aviso previo.

INFORMATIONS GENERALES

Ce catalogue permet de commander correctement les pièces détachées

Les commandes doivent être passées en indiquant:

1) le numero de code des pièces détachées suivi de leur description quantité désirée;

2) le code alphanumérique dans la deuxième colonne du tableau;

Les plans des pièces détachées sont fournis seulement à titre indicatif et ne représentent pas la pièce concernée.

Les données de ce catalogue sont citées seulement à titre indicatif et peuvent être l'objet de modifications sans avis préalable.

ESEMPIO
EXAMPLE
EXEMPLE
BEISPIEL

Rif.	Codici
MODULE:Particolari	
10505	540903
10510	540908
10515	15065/A
10520	540086
10525	540028

Note

Tutte le informazioni riportate si intendono aggiornate alla data di stampa. Il Produttore si riserva il diritto di apportare qualsiasi modifica richiesta dallo sviluppo evolutivo dei suddetti prodotti.

Per la sicurezza, la garanzia, l'affidabilità ed il valore della lavastoviglie usa solo ricambi originali. **Per alcuni codici, sono richieste quantità minime d'ordine.**

Attenzione

Questo libretto è parte integrante della lavastoviglie e, in caso di passaggio di proprietà, deve essere consegnato al nuovo acquirente.

Remarque

Toutes les informations contenues dans ce manuel s'entendent mises à jour à la date d'impression. En raison du développement constant de ses produits, usine se réserve le droit d'apporter à tout instant les modifications qu'elle jugera utiles.

Pour la sécurité, la garantie, la fiabilité et la valeur de votre lave-vaisselles n'utilisez que des pièces de rechange d'origine. **Pour quelque référence on demande un minimum de pièces par commande**

Attention

Ce manuel doit être considéré comme partie intégrante de la lave-vaisselles, en cas de transfert de propriété, doit toujours être remis au nouveau propriétaire.

Note

The information contained herein is valid at the time of going to print. The Company reserves the right to make any changes required by the future development of the above-mentioned products.

For your safety, as well as to preserve the warranty reliability and worth of your dishwashers, use original spare parts only. **For some codes a minimum quantity for order is required.**

Warning

This manual forms an integral part of the dishwashers and - if a transfer of title occurs - must always be handed over to the new owner.

Hinweis

Die Der Hersteller behält sich das Recht vor, jegliche, durch eine Weiterentwicklung der genannten Produkte bedingte Änderungen vornehmen zu können.

Verwenden Sie für Ihre Sicherheit, die Garantie, die Zuverlässigkeit und den Wert Ihrer machine originale Ersatzteile. **Für bestimmte Code nummer werden mindesten bestellungen verlangt.**

Achtung

Diese Betriebsanleitung ist Bestandteil des machine und muss bei seinem Weiterverkauf dem neuen Besitzer ausgehändigt werden.



Code 999XYYYY

Model DESCRIPTION

S/N 04012345 **Type**

CL/Part



400VAC3N 50HZ 8A

3500W 500W



16A

TECHICAL SPECIFICATION

200-500

MADE IN ITALY

Pressione Dinamica alimentazione idrica 200-500

Pression dynamique arrivee d'eau

Dynamic pressure water supply

Dynamischer Druck asserreinlauf

Pressione dinamica vapore saturo

Pression dynamique vapeur satueeè

Dymanischer Druck gesattigter Dampf

Pression Dinamica Vapor Saturado

Temperatura massima acqua in ingresso **60°C**

Temperature max eau a l'entre

Maximale Temperatur Wasseranschlu

Maximum Water temperature in-feeding

Model 

S/N 

CODE 999 XX YYYY

FAMIGLIA PRODOTTO

FAMILY PRODUCT

FAMILLE DU PRODUIT

FAMILIA PRODUCTO

FAMILIE DES PRODUKTES

CODICE MODELLO

CODE MODEL

CODE ARTICLE

CODIGO MODELO

KODE VON MODELL

S/N 04 012345

ANNO

YEAR

ANNÉE

AN^o

JAHR

NUMERO DI SERIE

SERIAL NUMBER

NUMÉRO DI SÉRIE

NUMERO DI SERIE

SERIENNUMMER

1. Spare parts

General body parts.....	7
Lockup system	9
Control panel and switches.....	11
Electric control components.....	13
Solenoid valve group	15
Booster pump.....	17
DVGW	19
Rinse aid dispenser group.....	21
Boiler group	23
3 ways connection	25
Wash pump	27
Dosing detergent group.....	29
Drain pump group.....	31
Pressure switch group with air trap ...	33
Turret group with rotating arms	35
Turret group with rotating arms	37

1.1 Voltage codes

Volt	Voltage code
A	3/N/PE~380-400V 50-60Hz
D	3/PE~200-210V 50-60Hz
F	2/PE~220-240V 50-60Hz
G	3/N/PE~415V 50-60Hz
H	3/PE~220-230V 50-60Hz
K	3/PE~380-400V 50-60Hz
L	3/PE~415V 50-60Hz
M	3/PE~440V 60Hz
P	1/N/PE~220-230V 50-60Hz
R	2/PE~220-240V 50-60Hz
U	1/N/PE~240V 50-60Hz
V	3/PE~240V 50-60Hz
W	1/N/PE~100-110V 50-60Hz

1.2 Product codes

Product code	Full name
Model codes	
e	ELECTRONICAL SWITCHES
mc	SIMPLE BODY VERSION
uw	LOWER AND UPPER VERSION
Type codes	
18ER	18ER
Accessory codes	
bp	BOOSTER PUMP
dvgw	DVGW
dd	DETERGENT DISPENCER
dp	DRAIN PUMP

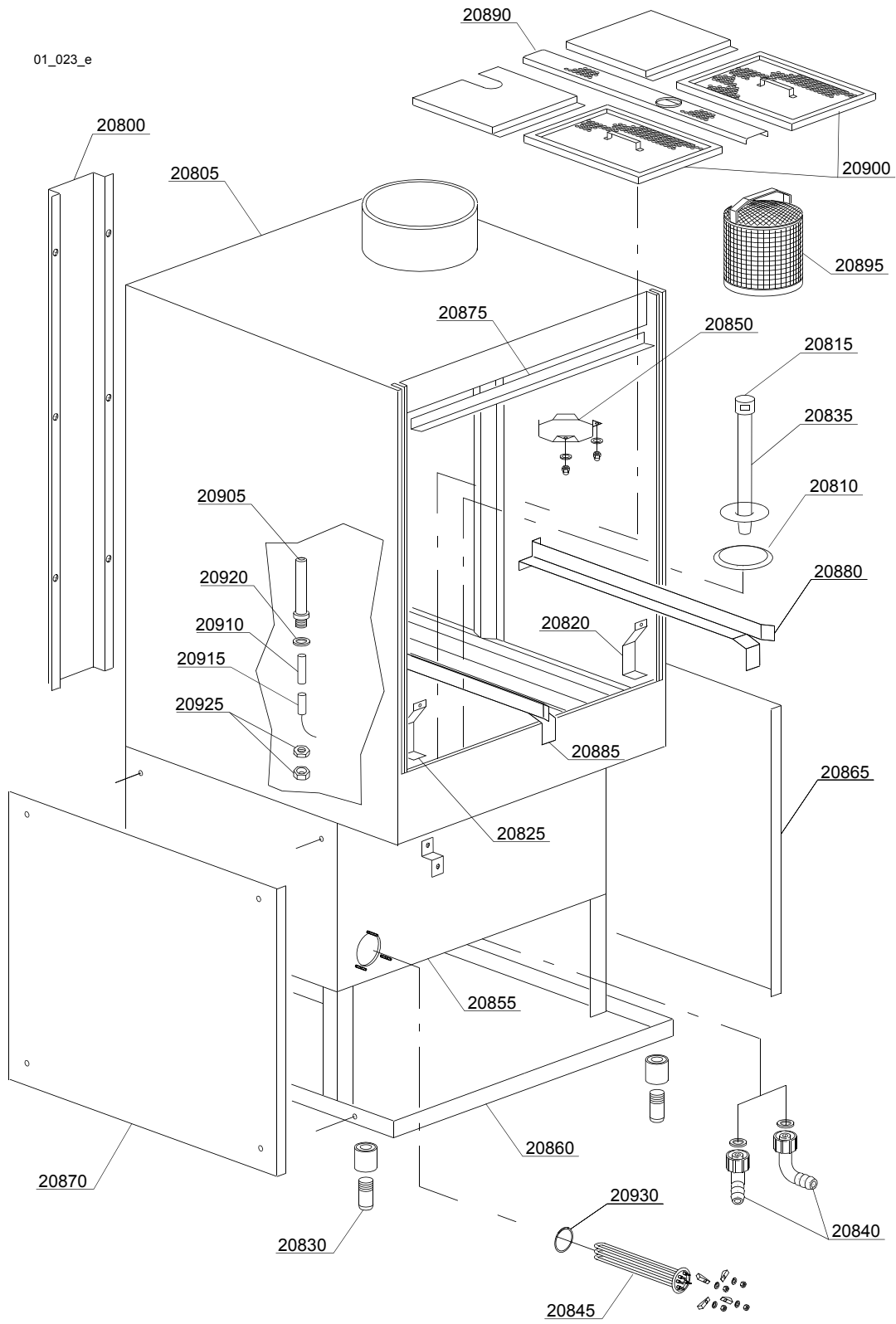

Spare parts

ID	P-code	SN from	SN to	Mod.	Acces.	Volt	Description
Module:General body parts							
20800	88907		-	mc			Back panel
20805	80901		-	mc			Complete structure
20810	11600002		-	mc			Flange O-ring
20815	11600019		-	mc			Terminal overflow pipe
20820	80936		-	mc			Right splash guard
20825	80937		-	mc			Left splash guard
20830	80116		-	mc			Foot 2" M65
20835	80226		-	mc			Overflow pipe
20840	15613		-	mc			Elbow 1¼"
20845	30001010		-	mc		A,H,K,L,P,R,U,V	Heating element 6/6,53KW 230/240V 3
20845	30001011		-			A,H,K,L,P,R,U,V	Heating element 9/9,8KW 230/240V 3
20845	30001011/C		-			M	heating element 9KW 254/440V
20850	80931		-	mc			Chimney splash guard
20855	80900		-	mc			Tank
20860	80904		-	mc			Frame base
20865	80907		-	mc			Right side panel
20870	80908		-	mc			Left side panel
20875	80935		-	mc			Upper chimney
20880	80910		-	mc			Right internal slide
20885	80911		-	mc			Left internal slide
20890	80930		-	mc			Sleeper holder-filter
20895	80720		-	mc			Suction filter
20900	80721		-	mc			Strainer plate
20905	88120		-	mc			Sensor holder
20910	88120/A		-	mc			Reed spacer
20915	2000309		-	mc			Sensor
20920	10200171		-	mc			Gasket 17x25x2 (minimum 10 pieces)
20925	22214		-	mc			Nut

e=ELECTRONICAL SWITCHES, mc=SIMPLE BODY VERSION, uw=LOWER AND UPPER VERSION

18ER=18ER

bp=BOOSTER PUMP, dvgw=DVGW, dd=DETERGENT DISPENCER, dp=DRAIN PUMP

A=3/N/PE~380-400V 50-60Hz, D=3/PE~200-210V 50-60Hz, F=2/PE~220-240V 50-60Hz, G=3/N/PE~415V 50-60Hz, H=3/PE~220-230V 50-60Hz, K=3/PE~380-400V 50-60Hz, L=3/PE~415V 50-60Hz, M=3/PE~440V 60Hz, P=1/N/PE~220-230V 50-60Hz, R=2/PE~220-240V 50-60Hz, U=1/N/PE~240V 50-60Hz, V=3/PE~240V 50-60Hz, W=1/N/PE~100-110V 50-60Hz

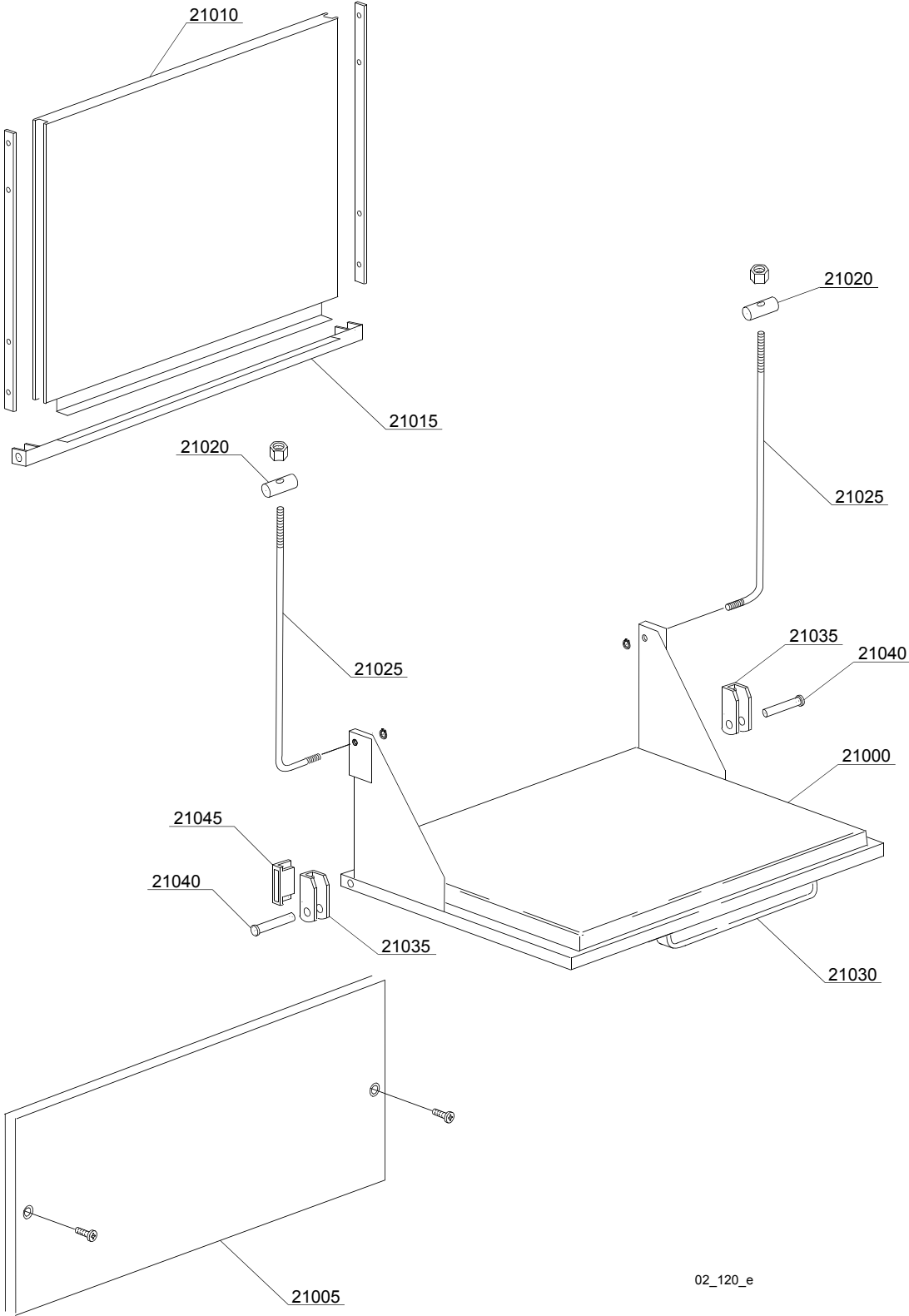

02_120_e

Spare parts

ID	P-code	SN from	SN to	Mod.	Acces.	Volt	Description
Module: Lockup system							
21000	80903		-				Lower door
21005	80906		-				Front panel
21010	80902		-				Upper door
21015	80938		-				Levers support
21020	22219		-				Pin
21025	22220		-				Door rod
21030	80750		-				Handle
21035	22206/B		-				Door hinge
21040	22220/A		-				Pin for door
21045	80232		-				Door magnet

e=ELECTRONICAL SWITCHES, mc=SIMPLE BODY VERSION, uw=LOWER AND UPPER VERSION

18ER=18ER

bp=BOOSTER PUMP, dvgw=DVGW, dd=DETERGENT DISPENCER, dp=DRAIN PUMP

A=3/N/PE~380-400V 50-60Hz, D=3/PE~200-210V 50-60Hz, F=2/PE~220-240V 50-60Hz, G=3/N/PE~415V 50-60Hz, H=3/PE~220-230V 50-60Hz, K=3/PE~380-400V 50-60Hz, L=3/PE~415V 50-60Hz, M=3/PE~440V 60Hz, P=1/N/PE~220-230V 50-60Hz, R=2/PE~220-240V 50-60Hz, U=1/N/PE~240V 50-60Hz, V=3/PE~240V 50-60Hz, W=1/N/PE~100-110V 50-60Hz

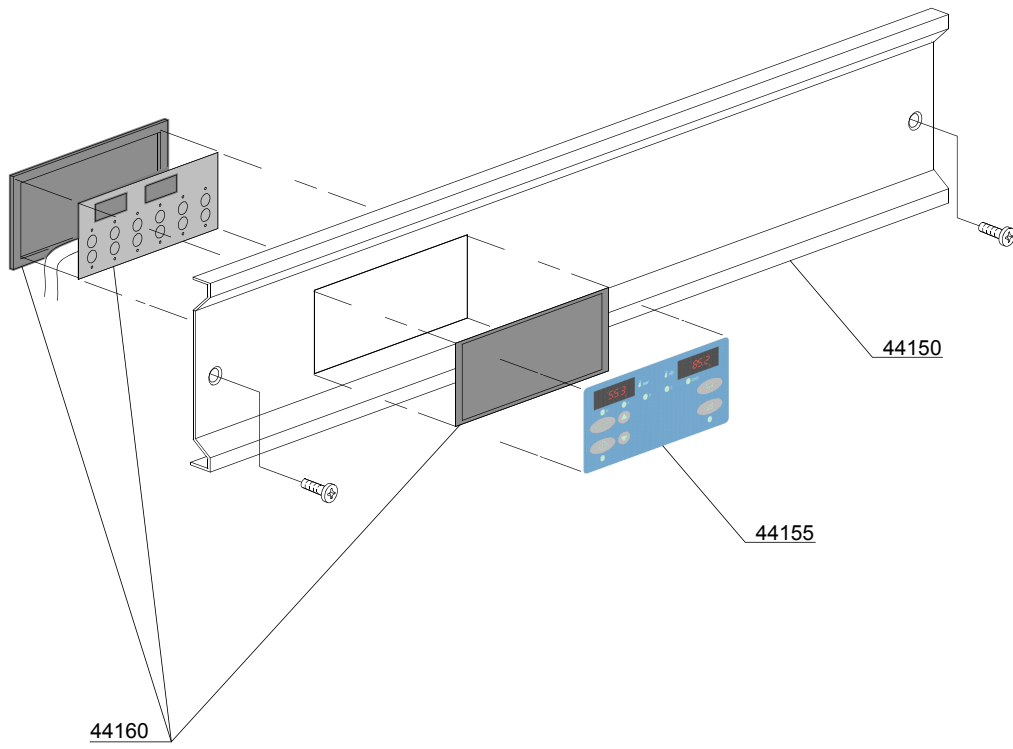

03_049_e

Spare parts

ID	P-code	SN from	SN to	Mod.	Acces.	Volt	Description
Module:Control panel and switches							
44150	80909		-	e,mc			Stainless steel control panel
44155	50571		-	e,mc			Silkscreen processed grill membrane push button-driven dp+ws
44155	50575		-	e,mc			Neutral Silkscreen processed grill membrane push button-driven dp+ws
44160	50570/A		-	e,mc			Complete membrane push button-driver L=1500

e=ELECTRONICAL SWITCHES, mc=SIMPLE BODY VERSION, uw=LOWER AND UPPER VERSION
18ER=18ER

bp=BOOSTER PUMP, dvgw=DVGW, dd=DETERGENT DISPENCER, dp=DRAIN PUMP

A=3/N/PE~380-400V 50-60Hz, D=3/PE~200-210V 50-60Hz, F=2/PE~220-240V 50-60Hz, G=3/N/PE~415V 50-60Hz, H=3/PE~220-230V 50-60Hz, K=3/PE~380-400V 50-60Hz, L=3/PE~415V 50-60Hz, M=3/PE~440V 60Hz, P=1/N/PE~220-230V 50-60Hz, R=2/PE~220-240V 50-60Hz, U=1/N/PE~240V 50-60Hz, V=3/PE~240V 50-60Hz, W=1/N/PE~100-110V 50-60Hz

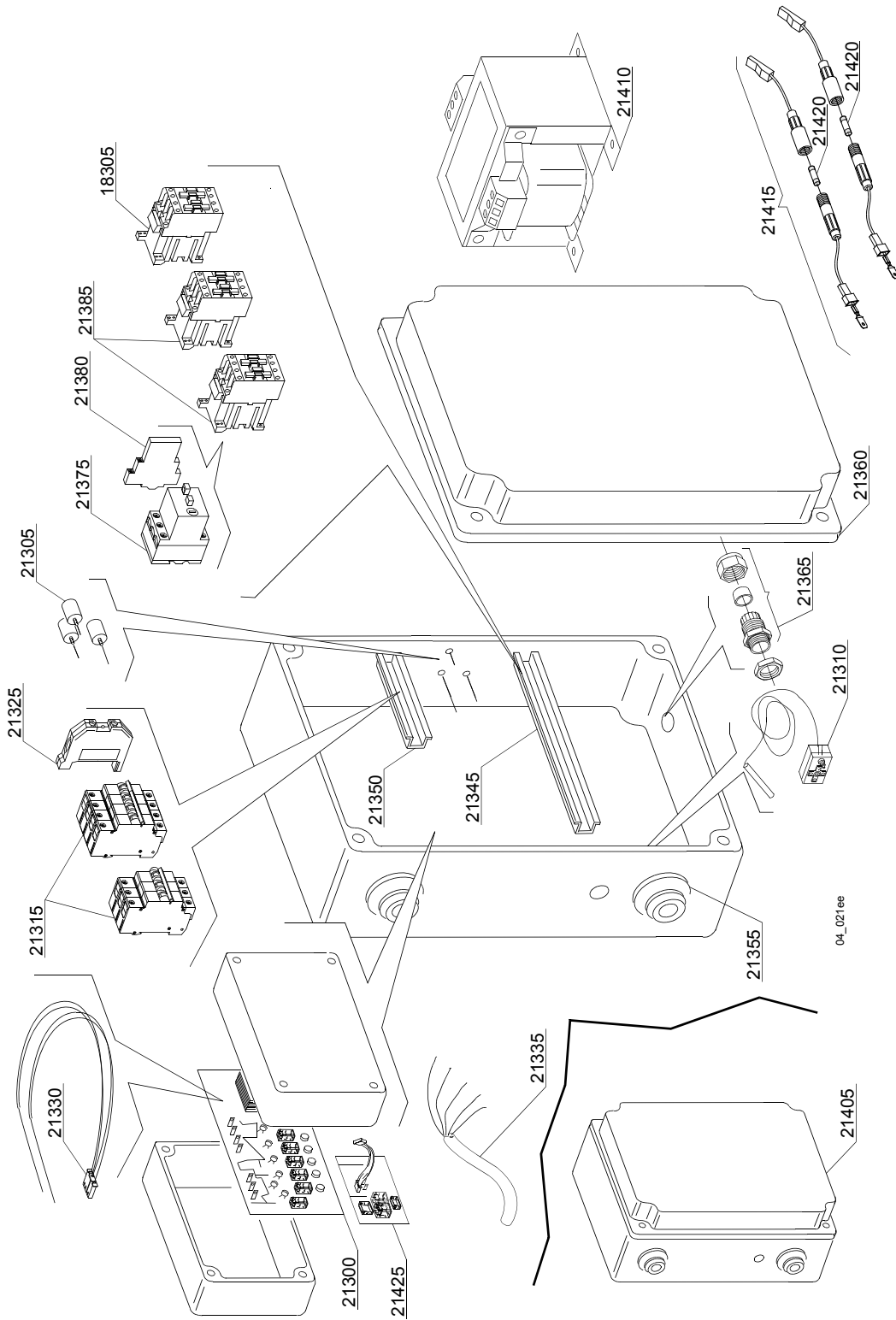

Spare parts

ID	P-code	SN from	SN to	Mod.	Acces.	Volt	Description
Module:Electric control components							
21300	50569		-			A,H,K,P	Timer
21305	15149		-			A,H,K,P	Filter F3
21305	15187		-			M	Low noise filter F3 440Vac3
21310	2000430		-				Thermostat
21315	2000409		-				Automatic fuse C40
21315	2000411		-				Automatic fuse C32
21325	10300401		-				Clamp
21330	50562		-				Sensor
21335	80200		-			A,G	Power supply cable 5x4x3400
21335	75359		-			D,F,H,K,L, M,R,V	4x6 flame-retardant cable
21345	80408		-				L=345mm slide
21350	80409		-				L=140mm slide
21355	80417		-				lead through rubber
21360	80407		-				Plastic box
21365	80414		-				Cable-press
21370	15086		-				Contacteur 230 V
21375	2000390		-				Motorprotector 1 - 1.6A
21380	3006080		-				Auxiliary contact LMS25
21385	10300050		-			A,F,H,K,P, R	Contacteur 25A/12A 4NA 230V
21385	10300052		-			A,F,H,K,P, R	36A/20A contactor - 230V 50/60HZ
21385	10300054		-			A,F,H,K,P, R	Contacteur 25A/16A 4NA 230V
21410	15384		-				500VA 0-230-400-415-440/230V tranformer
21410	15381		-				160VA 0-230-400-415-440/230V tranformer
21415	15147		-				5x20 fuse holder
21420	15161		-				5x20 1,6A fuse
21425	50559		-				Electronic Timer optional+On-Board EXP-PS

e=ELECTRONICAL SWITCHES, mc=SIMPLE BODY VERSION, uw=LOWER AND UPPER VERSION

18ER=18ER

bp=BOOSTER PUMP, dvgw=DVGW, dd=DETERGENT DISPENCER, dp=DRAIN PUMP

A=3/N/PE~380-400V 50-60Hz, D=3/PE~200-210V 50-60Hz, F=2/PE~220-240V 50-60Hz, G=3/N/PE~415V 50-60Hz, H=3/PE~220-230V 50-60Hz, K=3/PE~380-400V 50-60Hz, L=3/PE~415V 50-60Hz, M=3/PE~440V 60Hz, P=1/N/PE~220-230V 50-60Hz, R=2/PE~220-240V 50-60Hz, U=1/N/PE~240V 50-60Hz, V=3/PE~240V 50-60Hz, W=1/N/PE~100-110V 50-60Hz

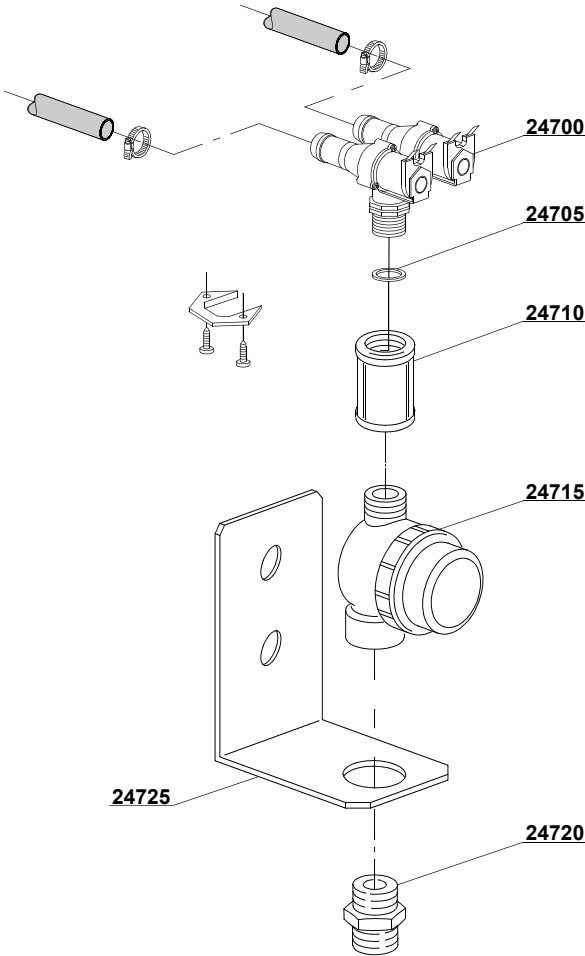

05_006_e

Spare parts

ID	P-code	SN from	SN to	Mod.	Acces.	Volt	Description
Module:Solenoid valve group							
24700	30001001		-				Solenoid valve
24705	N.C.		-				Pression reducing valve
24710	80275		-				Pipe coupling
24715	2000121		-				Filter
24720	12025		-				Coupling
24725	22236		-				Support

e=ELECTRONICAL SWITCHES, mc=SIMPLE BODY VERSION, uw=LOWER AND UPPER VERSION

18ER=18ER

bp=BOOSTER PUMP, dvgw=DVGW, dd=DETERGENT DISPENCER, dp=DRAIN PUMP

A=3/N/PE~380-400V 50-60Hz, D=3/PE~200-210V 50-60Hz, F=2/PE~220-240V 50-60Hz, G=3/N/PE~415V 50-60Hz, H=3/PE~220-230V 50-60Hz, K=3/PE~380-400V 50-60Hz, L=3/PE~415V 50-60Hz, M=3/PE~440V 60Hz, P=1/N/PE~220-230V 50-60Hz, R=2/PE~220-240V 50-60Hz, U=1/N/PE~240V 50-60Hz, V=3/PE~240V 50-60Hz, W=1/N/PE~100-110V 50-60Hz

07_002_e

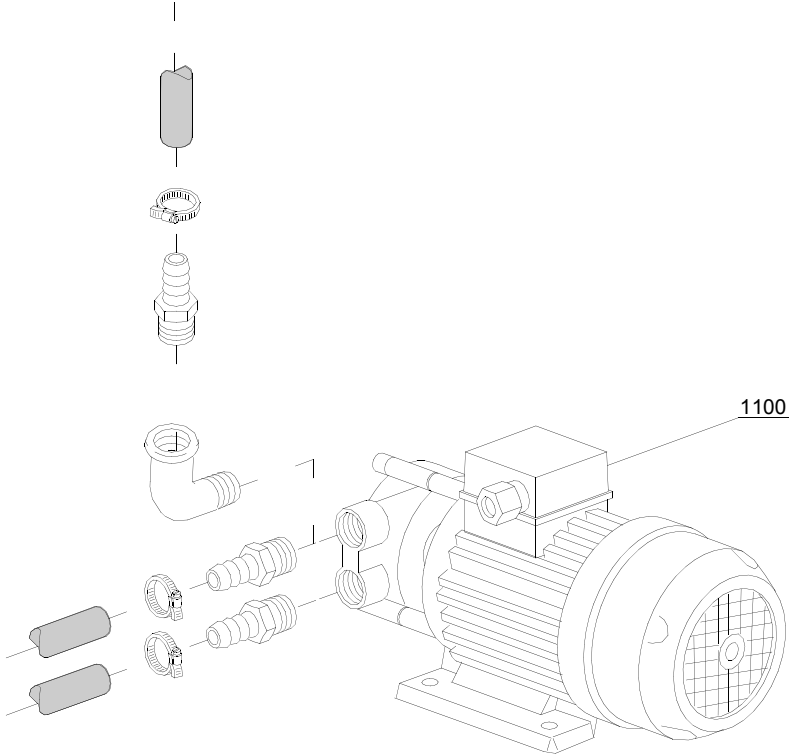

Spare parts

ID	P-code	SN from	SN to	Mod.	Acces.	Volt	Description
Module:Booster pump							
1100	15100		-		bp	A,F,G,H, K,L,P,R, U,V	Booster pump 0,5HP/0,375kW 50Hz 220-240V
1100	15100/A		-		bp	A,F,G,H, K,L,P,R, U,V	Booster pump - 0,5HP/ 0,37kW 60Hz

e=ELECTRONICAL SWITCHES, mc=SIMPLE BODY VERSION, uw=LOWER AND UPPER VERSION

18ER=18ER

bp=BOOSTER PUMP, dvgw=DVGW, dd=DETERGENT DISPENCER, dp=DRAIN PUMP

A=3/N/PE~380-400V 50-60Hz, D=3/PE~200-210V 50-60Hz, F=2/PE~220-240V 50-60Hz, G=3/N/PE~415V 50-60Hz,
H=3/PE~220-230V 50-60Hz, K=3/PE~380-400V 50-60Hz, L=3/PE~415V 50-60Hz, M=3/PE~440V 60Hz, P=1/N/PE~220-
230V 50-60Hz, R=2/PE~220-240V 50-60Hz, U=1/N/PE~240V 50-60Hz, V=3/PE~240V 50-60Hz, W=1/N/PE~100-110V
50-60Hz

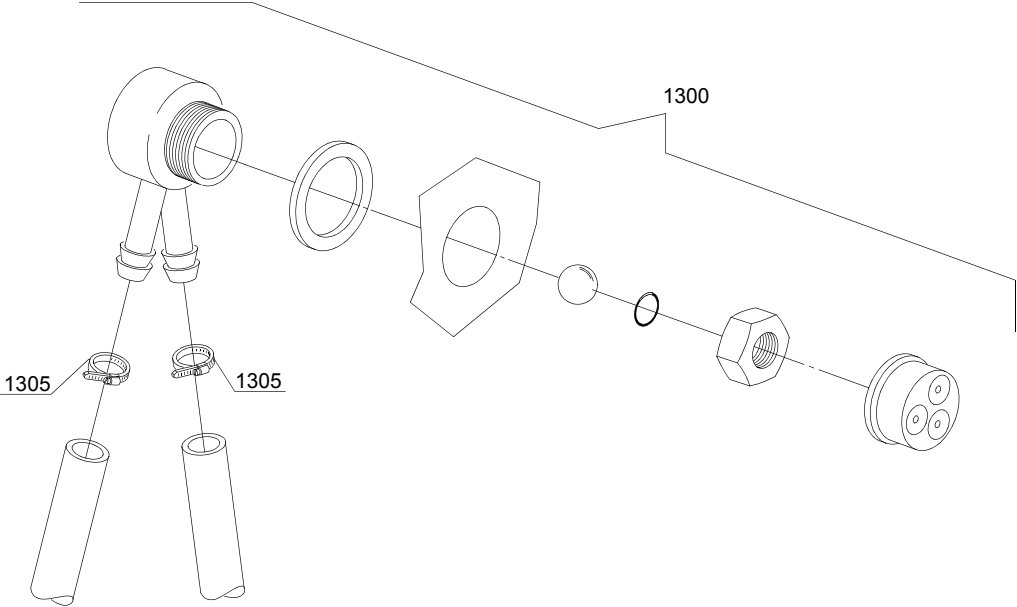

Spare parts

ID	P-code	SN from	SN to	Mod.	Acces.	Volt	Description
Module:DVGW							
1300	999900006		-		dvgw		DVGW assembly
1305	11807		-		dvgw		12/22 clamp (minimum 3 pieces)

e=ELECTRONICAL SWITCHES, mc=SIMPLE BODY VERSION, uw=LOWER AND UPPER VERSION

18ER=18ER

bp=BOOSTER PUMP, dvgw=DVGW, dd=DETERGENT DISPENCER, dp=DRAIN PUMP

A=3/N/PE~380-400V 50-60Hz, D=3/PE~200-210V 50-60Hz, F=2/PE~220-240V 50-60Hz, G=3/N/PE~415V 50-60Hz, H=3/PE~220-230V 50-60Hz, K=3/PE~380-400V 50-60Hz, L=3/PE~415V 50-60Hz, M=3/PE~440V 60Hz, P=1/N/PE~220-230V 50-60Hz, R=2/PE~220-240V 50-60Hz, U=1/N/PE~240V 50-60Hz, V=3/PE~240V 50-60Hz, W=1/N/PE~100-110V 50-60Hz

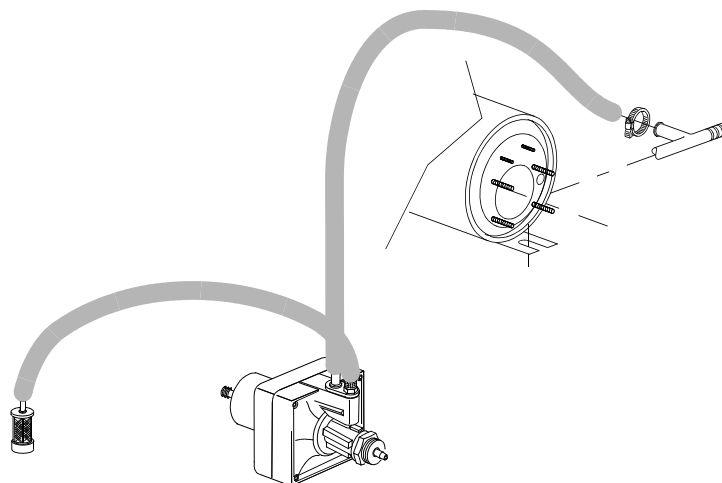
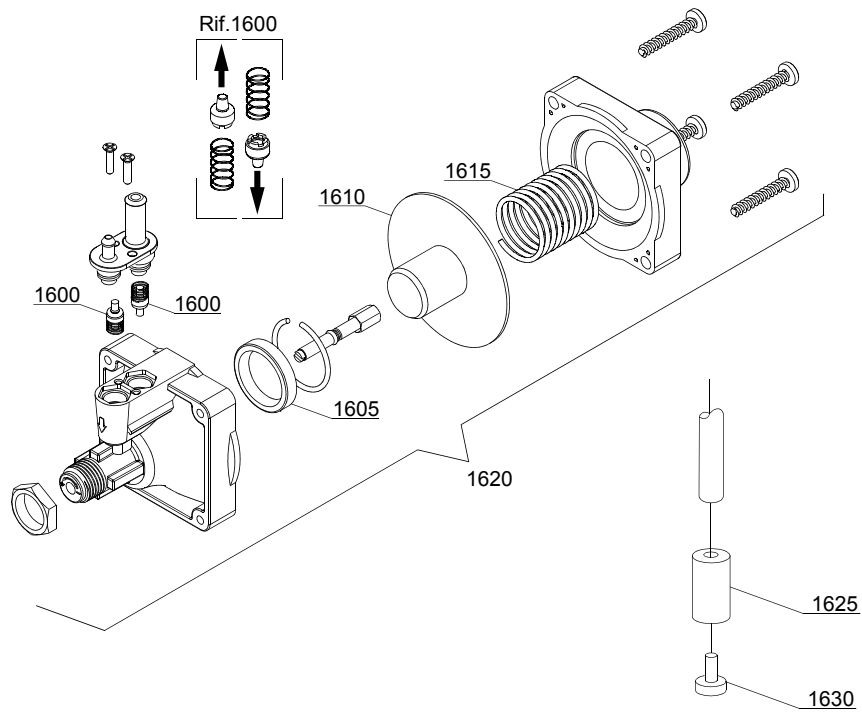

10_003_e

Spare parts

ID	P-code	SN from	SN to	Mod.	Acces.	Volt	Description
Module: Rinse aid dispenser group							
1600	10805		-				Tecnopro non return valve
1605	10806		-				Ø22 O-ring
1610	10807		-				Membrane
1615	10808		-				Spring
1620	10599999		-				Rinse aid pump
1625	12525		-				Counter-weight
1630	15058		-				Suction filter (minimum 3 pieces)

e=ELECTRONICAL SWITCHES, mc=SIMPLE BODY VERSION, uw=LOWER AND UPPER VERSION

18ER=18ER

bp=BOOSTER PUMP, dvgw=DVGW, dd=DETERGENT DISPENSER, dp=DRAIN PUMP

A=3/N/PE~380-400V 50-60Hz, D=3/PE~200-210V 50-60Hz, F=2/PE~220-240V 50-60Hz, G=3/N/PE~415V 50-60Hz, H=3/PE~220-230V 50-60Hz, K=3/PE~380-400V 50-60Hz, L=3/PE~415V 50-60Hz, M=3/PE~440V 60Hz, P=1/N/PE~220-230V 50-60Hz, R=2/PE~220-240V 50-60Hz, U=1/N/PE~240V 50-60Hz, V=3/PE~240V 50-60Hz, W=1/N/PE~100-110V 50-60Hz

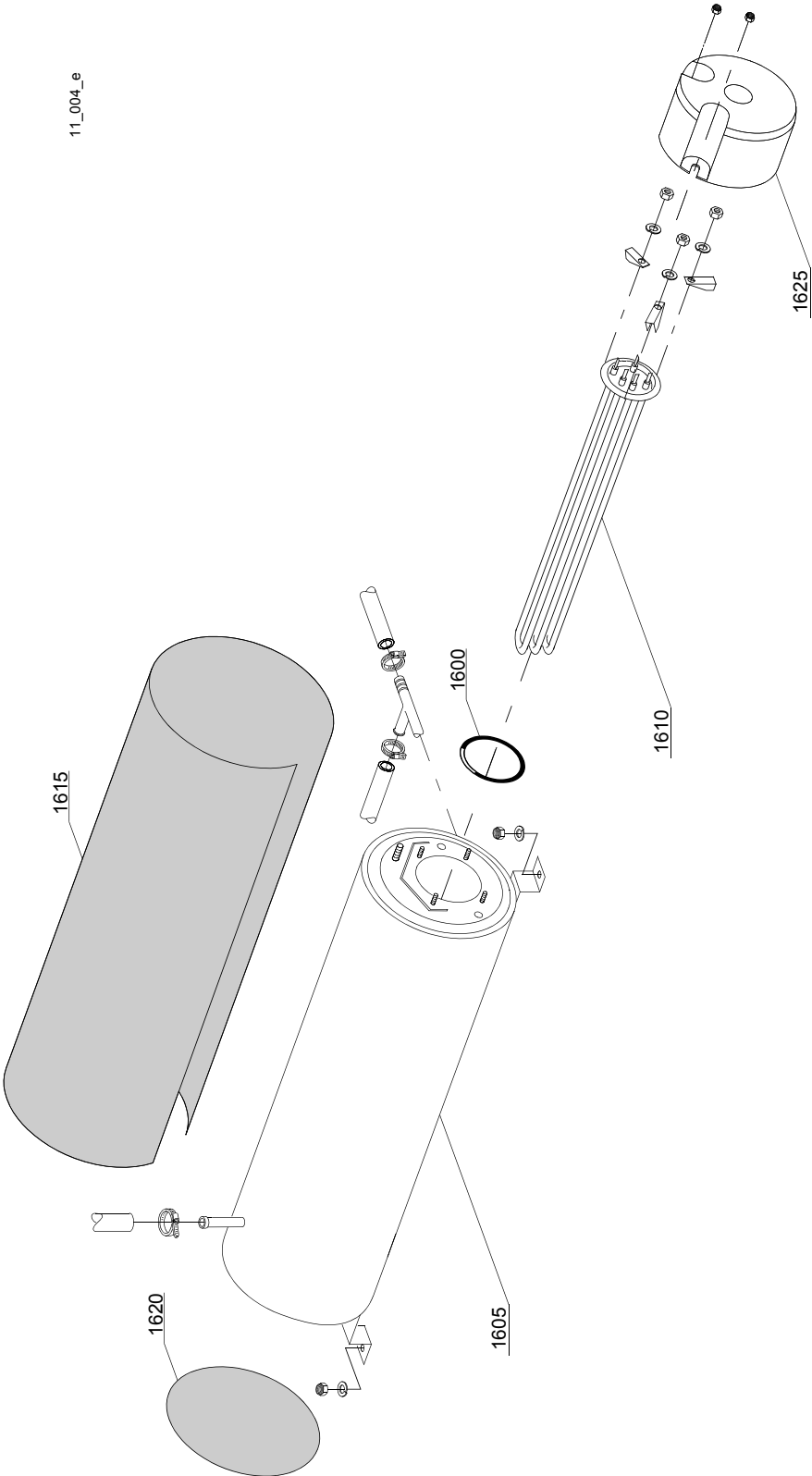

Spare parts

ID	P-code	SN from	SN to	Mod.	Acces.	Volt	Description
Module:Boiler group							
1600	13015		-				Gasket OR 6225 (minimum 5 pieces)
1605	80905		-				Boiler
1610	30001010		-			A,F,G,H,K,L, P,R,U,V	Heating element 6/6,53KW 230/240V 3
1610	30001011		-			A,F,G,H,K,L, P,R,U,V	Heating element 9/9,8KW 230/240V 3
1610	30001011/A		-			A,F,G,H,K,L, P,R,U,V	heating element12/13,07KW 230/240V 3
1610	30001011/C		-			M	heating element 9KW 254/440V
1615	30002030		-				Insulation boiler
1620	75205		-				Ø160 end piece (minimum 2 pieces)
1625	75311		-				Casing

e=ELECTRONICAL SWITCHES, mc=SIMPLE BODY VERSION, uw=LOWER AND UPPER VERSION

18ER=18ER

bp=BOOSTER PUMP, dvgw=DVGW, dd=DETERGENT DISPENCER, dp=DRAIN PUMP

A=3/N/PE~380-400V 50-60Hz, D=3/PE~200-210V 50-60Hz, F=2/PE~220-240V 50-60Hz, G=3/N/PE~415V 50-60Hz,
H=3/PE~220-230V 50-60Hz, K=3/PE~380-400V 50-60Hz, L=3/PE~415V 50-60Hz, M=3/PE~440V 60Hz, P=1/N/PE~220-
230V 50-60Hz, R=2/PE~220-240V 50-60Hz, U=1/N/PE~240V 50-60Hz, V=3/PE~240V 50-60Hz, W=1/N/PE~100-110V
50-60Hz

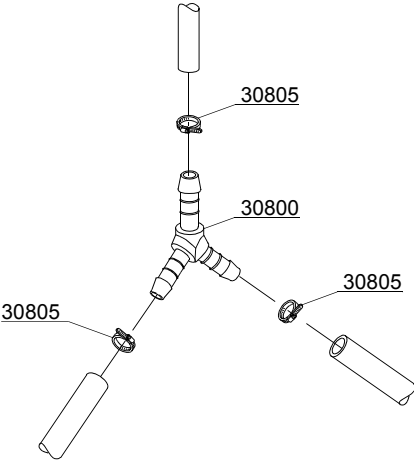

12_003ae

Spare parts

ID	P-code	SN from	SN to	Mod.	Acces.	Volt	Description
Module:3 ways connection							
30800	540091		-				Ø12 mm plastic 3 ways connection
30805	11807		-				Clamp 12-22 (minimum 3 pieces)

e=ELECTRONICAL SWITCHES, mc=SIMPLE BODY VERSION, uw=LOWER AND UPPER VERSION

18ER=18ER

bp=BOOSTER PUMP, dvgw=DVGW, dd=DETERGENT DISPENCER, dp=DRAIN PUMP

A=3/N/PE~380-400V 50-60Hz, D=3/PE~200-210V 50-60Hz, F=2/PE~220-240V 50-60Hz, G=3/N/PE~415V 50-60Hz, H=3/PE~220-230V 50-60Hz, K=3/PE~380-400V 50-60Hz, L=3/PE~415V 50-60Hz, M=3/PE~440V 60Hz, P=1/N/PE~220-230V 50-60Hz, R=2/PE~220-240V 50-60Hz, U=1/N/PE~240V 50-60Hz, V=3/PE~240V 50-60Hz, W=1/N/PE~100-110V 50-60Hz

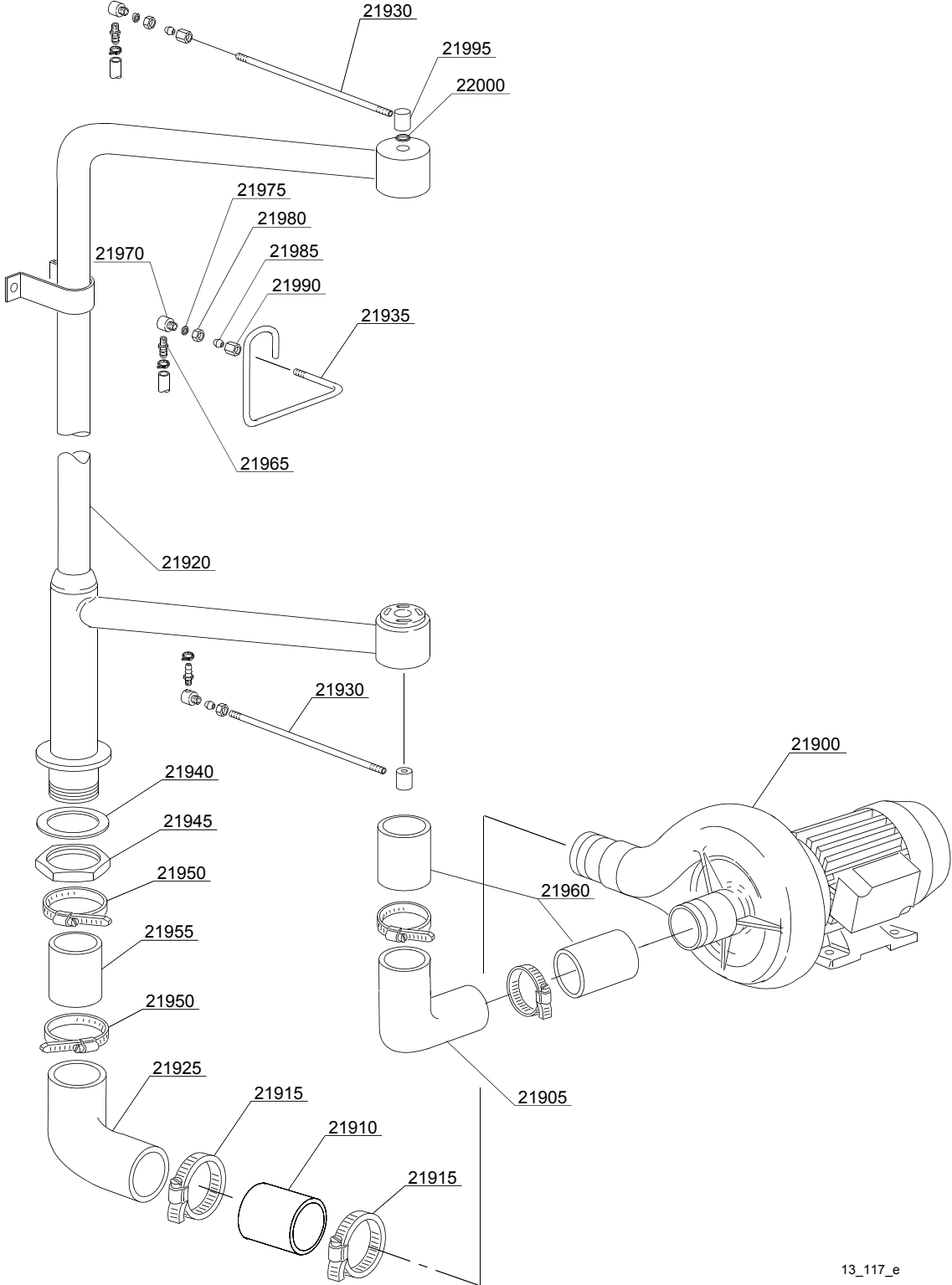

13_117_e

Spare parts

ID	P-code	SN from	SN to	Mod.	Acces.	Volt	Description
Module: Wash pump							
21900	80913		-	uw		A,H	Pump 4Hp/3kW
21900	80914		-	uw		G,L,U,V	wash pump 4Hp/3kW 240/415V 50Hz
21900	80916		-	uw		A,F,H,K,P	wash pump - 4Hp/3kW 60Hz
21905	80251		-	uw			Suction elbow
21910	80501		-	uw			Coupling pipe 94
21915	11837		-	uw			Clamp 80-100
21920	80211		-	uw			Wash ramp
21925	80252		-	uw			Elbow
21930	80210		-	uw			Rinse collector
21935	10200361		-	uw			Filling pipe
21940	80208		-	uw			95x75x3 O-ring (minimum 2 pieces)
21945	80213/A		-	uw			Ramp fixing nut
21950	2902491		-	uw			60-80 clamp (minimum 2 pieces)
21955	80500		-	uw			Coupling pipe 63,5x90
21960	80502		-	uw			Coupling pipe 75x130mm
21965	12005		-	uw			Rubber holder ¼
21970	80231		-	uw			Pipe fitting
21975	10200171		-	uw			Gasket 17x25x2 (minimum 10 pieces)
21980	10200101		-	uw			Nut
21985	10200182		-	uw			Cone (minimum 3 pieces)
21990	10600016		-	uw			Nut
21995	10600202		-	uw			Coupling
22000	13009		-	uw			OR 2050 NBR O-ring (minimum 40 pieces)

e=ELECTRONICAL SWITCHES, mc=SIMPLE BODY VERSION, uw=LOWER AND UPPER VERSION

18ER=18ER

bp=BOOSTER PUMP, dvgw=DVGW, dd=DETERGENT DISPENCER, dp=DRAIN PUMP

A=3/N/PE~380-400V 50-60Hz, D=3/PE~200-210V 50-60Hz, F=2/PE~220-240V 50-60Hz, G=3/N/PE~415V 50-60Hz, H=3/PE~220-230V 50-60Hz, K=3/PE~380-400V 50-60Hz, L=3/PE~415V 50-60Hz, M=3/PE~440V 60Hz, P=1/N/PE~220-230V 50-60Hz, R=2/PE~220-240V 50-60Hz, U=1/N/PE~240V 50-60Hz, V=3/PE~240V 50-60Hz, W=1/N/PE~100-110V 50-60Hz

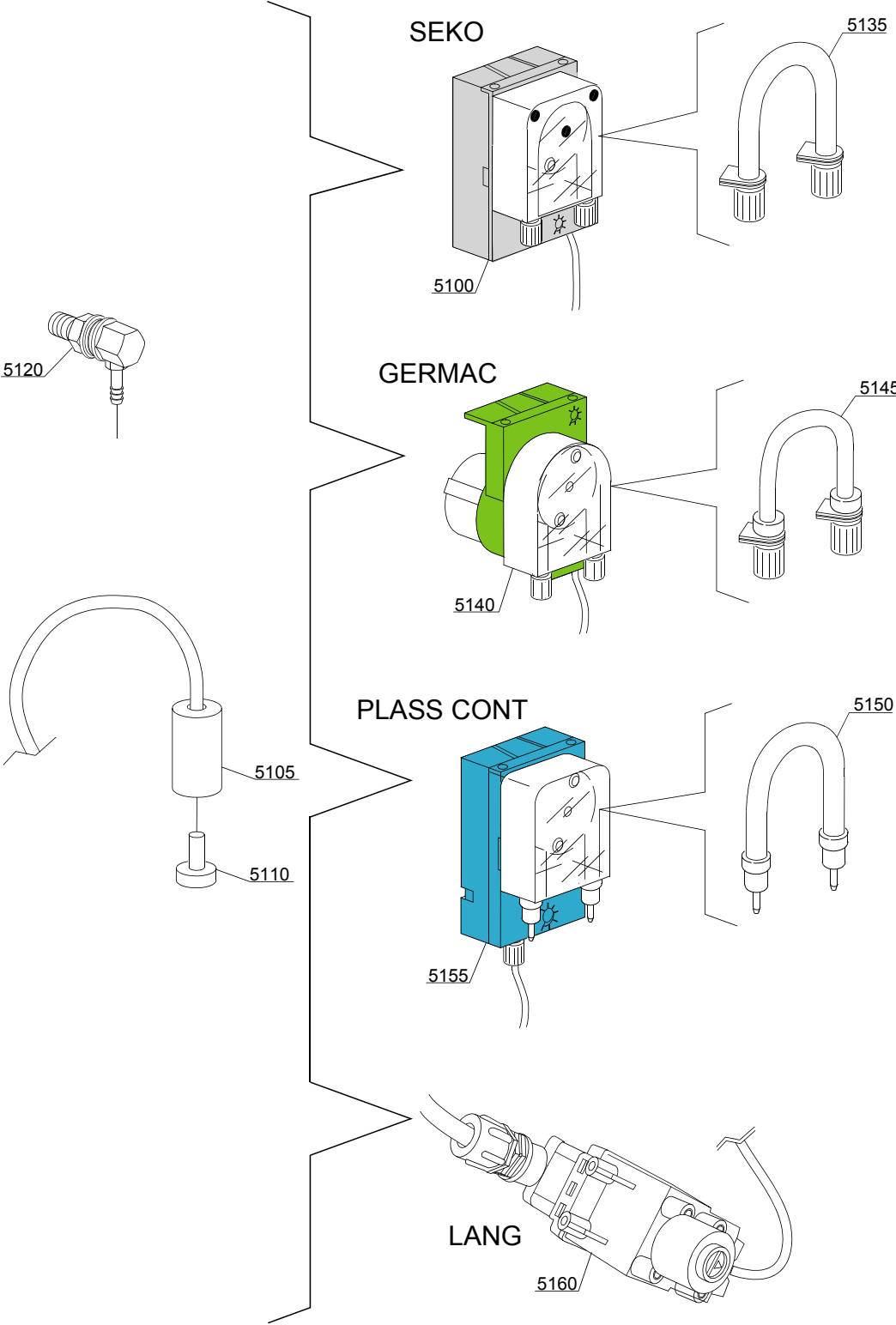

14_004_e

Spare parts

ID	P-code	SN from	SN to	Mod.	Acces.	Volt	Description
Module:Dosing detergent group							
5100	15985		-		dd		Seko detergent pump
5105	12525		-		dd		Counter-weight
5110	15058		-		dd		Suction filter (minimum 3 pieces)
5120	15123		-		dd		Steel injector
5125	15159		-		dd		OR O-ring (minimum 2 pieces)
5130	10200205		-		dd		Nut m12x1 (minimum 2 pieces)
5135	15185		-		dd		Ø 10 Seko thermoplastic pipe
5140	15985		-		dd		Germac detergent pump
5145	15108/E		-		dd		Ø 8 Germac thermoplastic pipe
5150	15985/A		-		dd		Ø 10 PLAS CONT thermoplastic pipe
5155	15985		-		dd		PLAS CONT detergent pump
5160	15108/L		-		dd		LANG detergent pump

e=ELECTRONICAL SWITCHES, mc=SIMPLE BODY VERSION, uw=LOWER AND UPPER VERSION

18ER=18ER

bp=BOOSTER PUMP, dvgw=DVGW, dd=DETERGENT DISPENCER, dp=DRAIN PUMP

A=3/N/PE~380-400V 50-60Hz, D=3/PE~200-210V 50-60Hz, F=2/PE~220-240V 50-60Hz, G=3/N/PE~415V 50-60Hz, H=3/PE~220-230V 50-60Hz, K=3/PE~380-400V 50-60Hz, L=3/PE~415V 50-60Hz, M=3/PE~440V 60Hz, P=1/N/PE~220-230V 50-60Hz, R=2/PE~220-240V 50-60Hz, U=1/N/PE~240V 50-60Hz, V=3/PE~240V 50-60Hz, W=1/N/PE~100-110V 50-60Hz

15_003_e

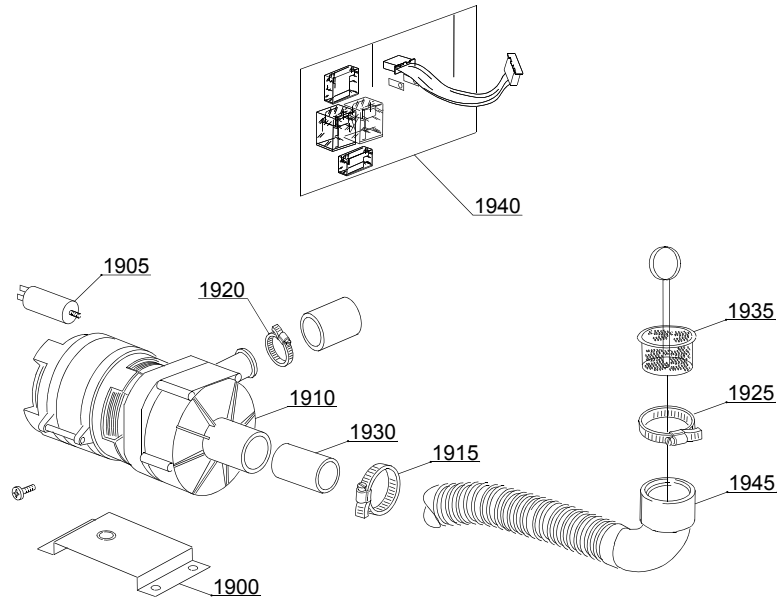

Spare parts

ID	P-code	SN from	SN to	Mod.	Acces.	Volt	Description
Module: Drain pump group							
1900	440122		-		dp		Pump support
1905	10702		-		dp		5 Uf Condenser
1910	10501/A		-		dp	A,F,G,H,K,L,P,R,U,V	Drain pump 0,10Hp/190W 230V 50Hz
1915	11806		-		dp		25/40 clamp (minimum 2 pieces)
1920	11836		-		dp		20/32 clamp (minimum 2 pieces)
1925	11809		-		dp		30/45 clamp (minimum 2 pieces)
1930	18044		-		dp		Ø28 top wash pipe
1935	10200039		-		dp		Flow drain filter
1940	50567		-		dp		Relay card
1945	11600050		-		dp		Suction pipe

e=ELECTRONICAL SWITCHES, mc=SIMPLE BODY VERSION, uw=LOWER AND UPPER VERSION

18ER=18ER

bp=BOOSTER PUMP, dvgw=DVGW, dd=DETERGENT DISPENCER, dp=DRAIN PUMP

A=3/N/PE~380-400V 50-60Hz, D=3/PE~200-210V 50-60Hz, F=2/PE~220-240V 50-60Hz, G=3/N/PE~415V 50-60Hz, H=3/PE~220-230V 50-60Hz, K=3/PE~380-400V 50-60Hz, L=3/PE~415V 50-60Hz, M=3/PE~440V 60Hz, P=1/N/PE~220-230V 50-60Hz, R=2/PE~220-240V 50-60Hz, U=1/N/PE~240V 50-60Hz, V=3/PE~240V 50-60Hz, W=1/N/PE~100-110V 50-60Hz

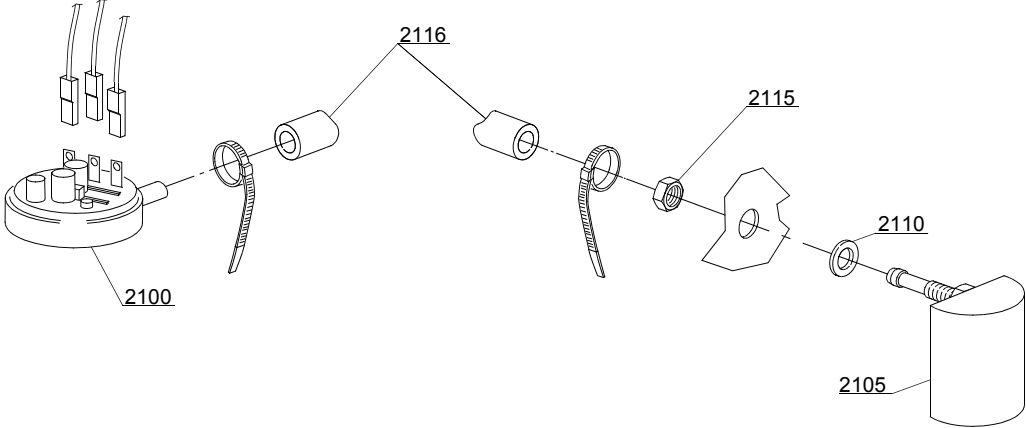

16_001_e

Spare parts

ID	P-code	SN from	SN to	Mod.	Acces.	Volt	Description
Module:Pressure switch group with air trap							
2100	80225		-	mc			Pressure switch
2105	135911		-				Air trap
2110	13301		-				Gasket 14x8x1,5 (minimum 10 pieces)
2115	11702		-				Nut M8 (minimum 10 pieces)
2116	14508		-				Pressure tube EPDM 4,5x9

e=ELECTRONICAL SWITCHES, mc=SIMPLE BODY VERSION, uw=LOWER AND UPPER VERSION

18ER=18ER

bp=BOOSTER PUMP, dvgw=DVGW, dd=DETERGENT DISPENCER, dp=DRAIN PUMP

A=3/N/PE~380-400V 50-60Hz, D=3/PE~200-210V 50-60Hz, F=2/PE~220-240V 50-60Hz, G=3/N/PE~415V 50-60Hz, H=3/PE~220-230V 50-60Hz, K=3/PE~380-400V 50-60Hz, L=3/PE~415V 50-60Hz, M=3/PE~440V 60Hz, P=1/N/PE~220-230V 50-60Hz, R=2/PE~220-240V 50-60Hz, U=1/N/PE~240V 50-60Hz, V=3/PE~240V 50-60Hz, W=1/N/PE~100-110V 50-60Hz

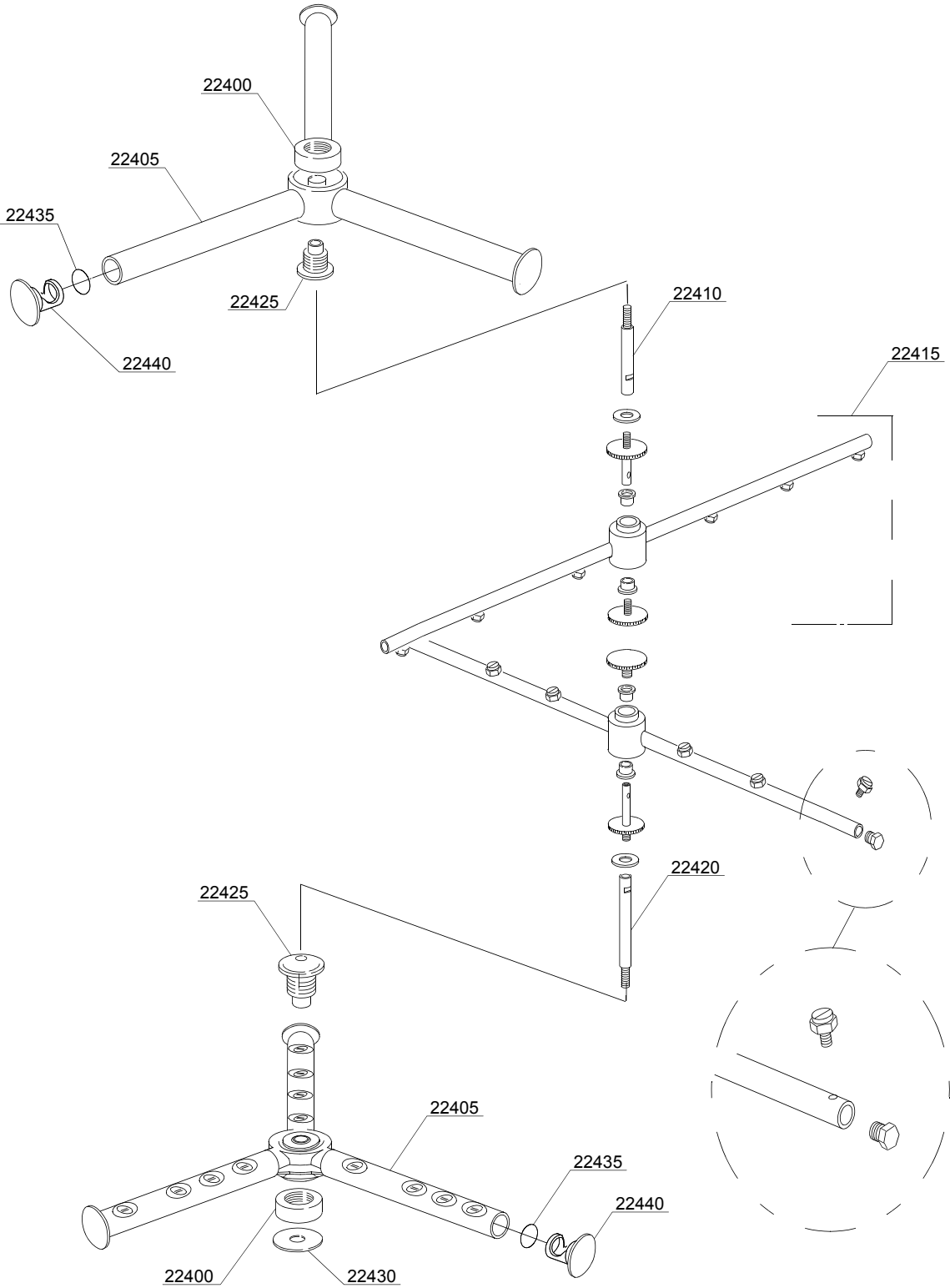

17_115_e

Spare parts

ID	P-code	SN from	SN to	Mod.	Acces.	Volt	Description
Module:Turret group with rotating arms							
22400	80222		-	uw			Nut for hub
22405	80218		-	uw			Wash group
22410	80321		-	uw			Top shaft
22415	90003		-	uw			Rinse group
22420	80320		-	uw			Lower shaft
22425	80221		-	uw			Holder
22430	11600033		-	uw			Flow reduction ring
22435	13023		-	uw			O-ring
22440	3003029		-	uw			Plug

e=ELECTRONICAL SWITCHES, mc=SIMPLE BODY VERSION, uw=LOWER AND UPPER VERSION

18ER=18ER

bp=BOOSTER PUMP, dvgw=DVGW, dd=DETERGENT DISPENCER, dp=DRAIN PUMP

A=3/N/PE~380-400V 50-60Hz, D=3/PE~200-210V 50-60Hz, F=2/PE~220-240V 50-60Hz, G=3/N/PE~415V 50-60Hz, H=3/PE~220-230V 50-60Hz, K=3/PE~380-400V 50-60Hz, L=3/PE~415V 50-60Hz, M=3/PE~440V 60Hz, P=1/N/PE~220-230V 50-60Hz, R=2/PE~220-240V 50-60Hz, U=1/N/PE~240V 50-60Hz, V=3/PE~240V 50-60Hz, W=1/N/PE~100-110V 50-60Hz

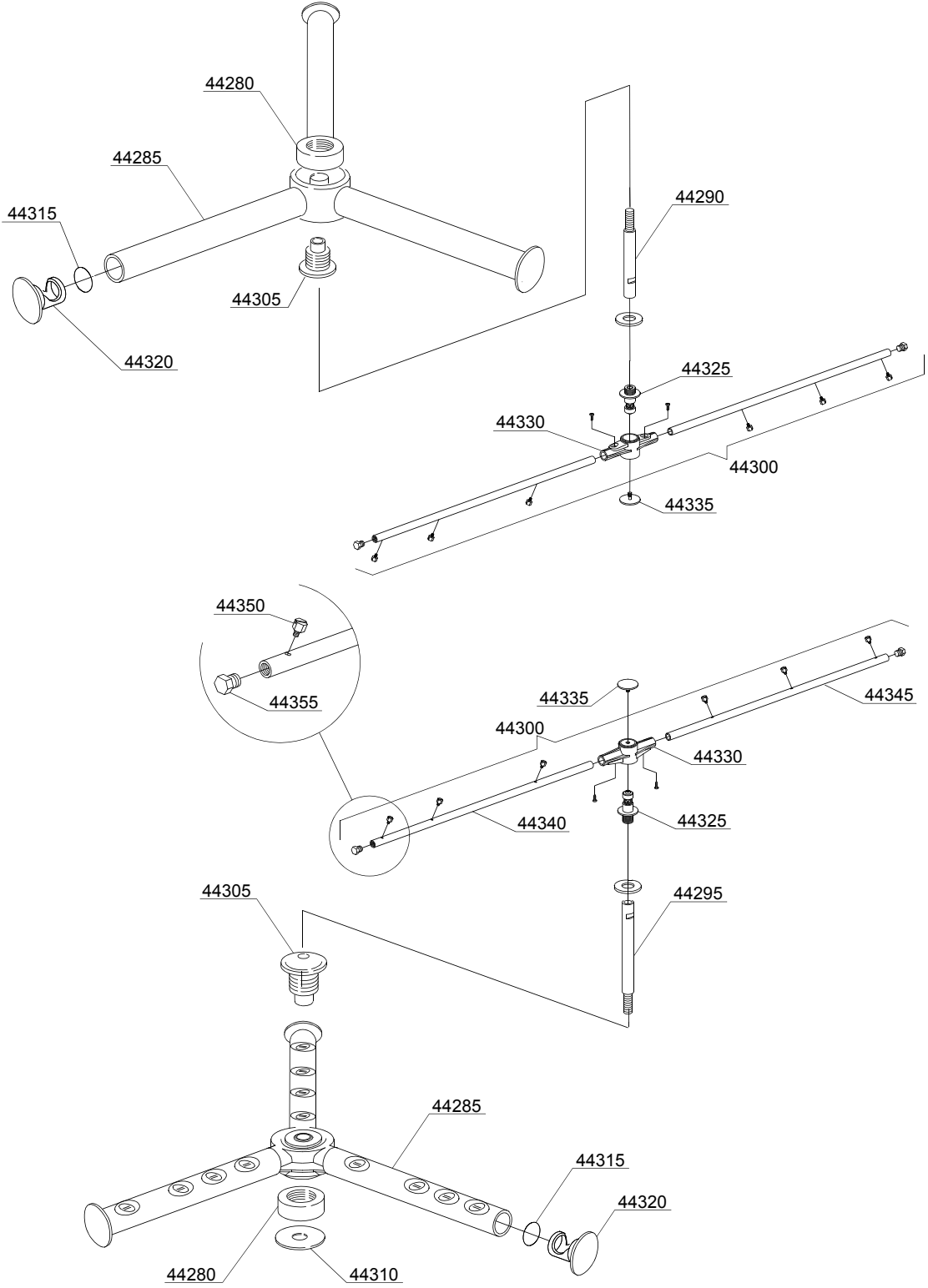

17_130_e

Spare parts

ID	P-code	SN from	SN to	Mod.	Acces.	Volt	Description
Module:Turret group with rotating arms							
44280	80222		-	uw			Nut for hub
44285	80218		-	uw			Wash group
44290	80321		-	uw			Top shaft
44295	80320		-	uw			Lower shaft
44300	90003		-	uw			Rinse group
44305	80221		-	uw			Holder
44310	11600033		-	uw			Flow reduction ring
44315	13023		-	uw			OR O-ring 131 (4093) NBR (minimum 10 pieces)
44320	3003029		-	uw			Plug
44325	10651		-	uw			Rinse axle
44330	10650		-	uw			Rinse arm
44335	10652		-	uw			Rinse arm screw
44340	10660		-	uw			Left rinse arm - stainless steel nozzle
44345	10659		-	uw			Right rinse arm - stainless steel nozzle
44350	560018		-	uw			Stanless steel rinse nozle
44355	560017		-	uw			Rinse arm plug

e=ELECTRONICAL SWITCHES, mc=SIMPLE BODY VERSION, uw=LOWER AND UPPER VERSION

18ER=18ER

bp=BOOSTER PUMP, dvgw=DVGW, dd=DETERGENT DISPENCER, dp=DRAIN PUMP

A=3/N/PE~380-400V 50-60Hz, D=3/PE~200-210V 50-60Hz, F=2/PE~220-240V 50-60Hz, G=3/N/PE~415V 50-60Hz, H=3/PE~220-230V 50-60Hz, K=3/PE~380-400V 50-60Hz, L=3/PE~415V 50-60Hz, M=3/PE~440V 60Hz, P=1/N/PE~220-230V 50-60Hz, R=2/PE~220-240V 50-60Hz, U=1/N/PE~240V 50-60Hz, V=3/PE~240V 50-60Hz, W=1/N/PE~100-110V 50-60Hz