

LAVABICCHIERI MASTER 21

TAVOLA
MA

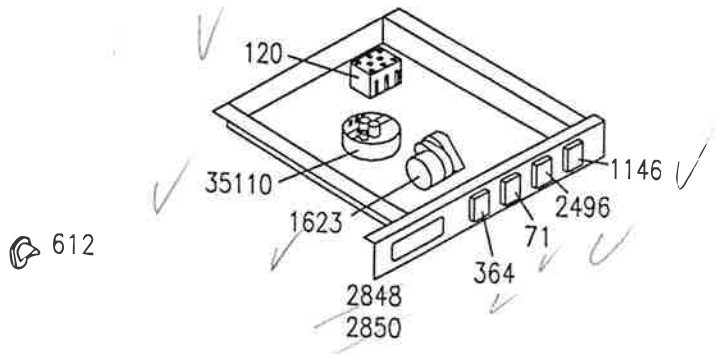

612

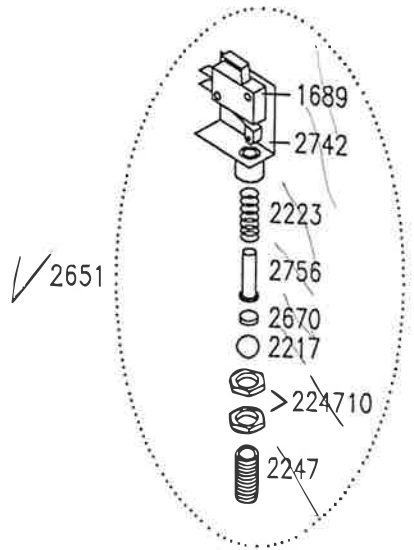

2651

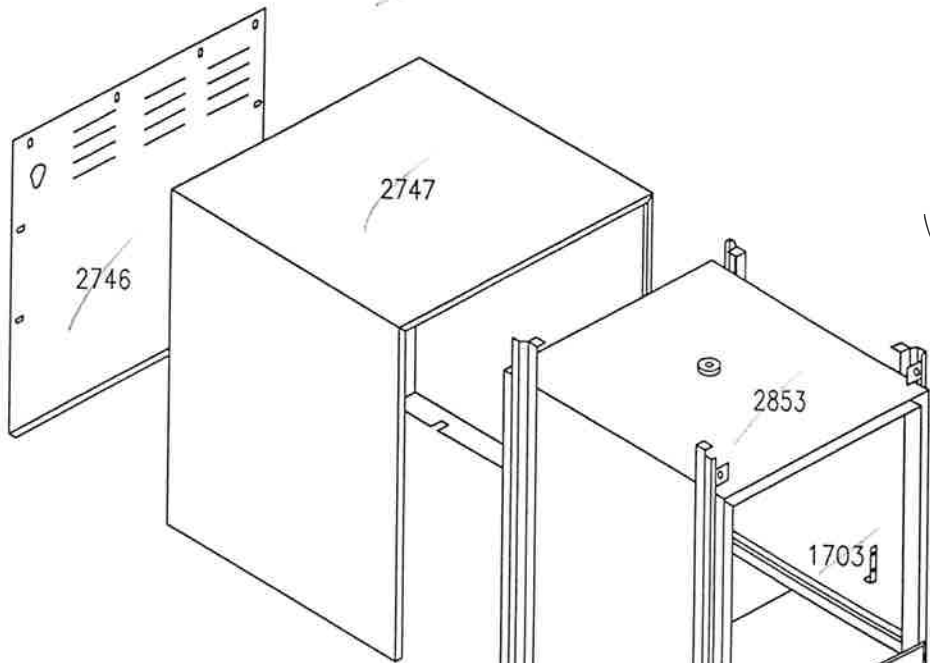

2194

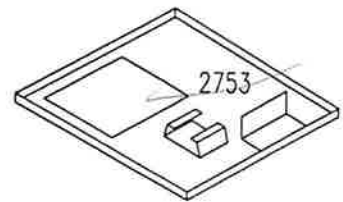
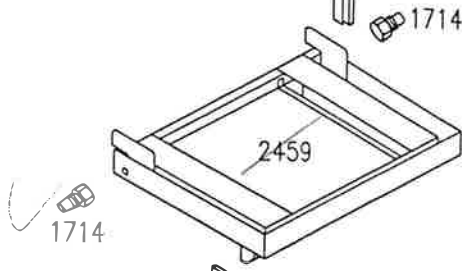
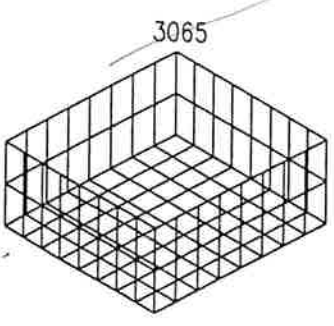
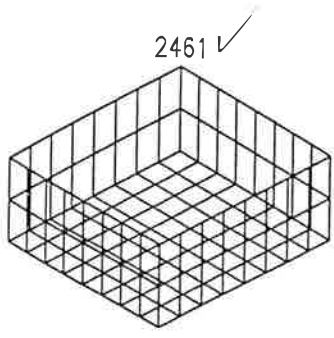
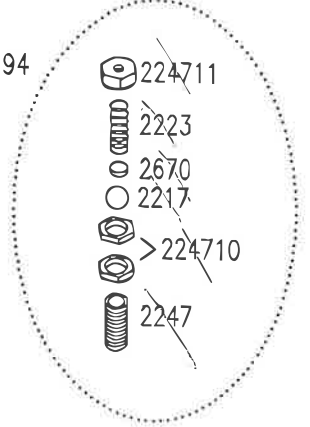

126010
126011



134

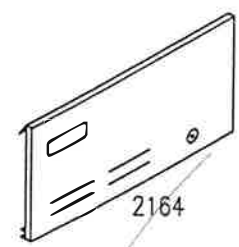
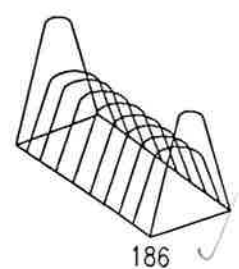

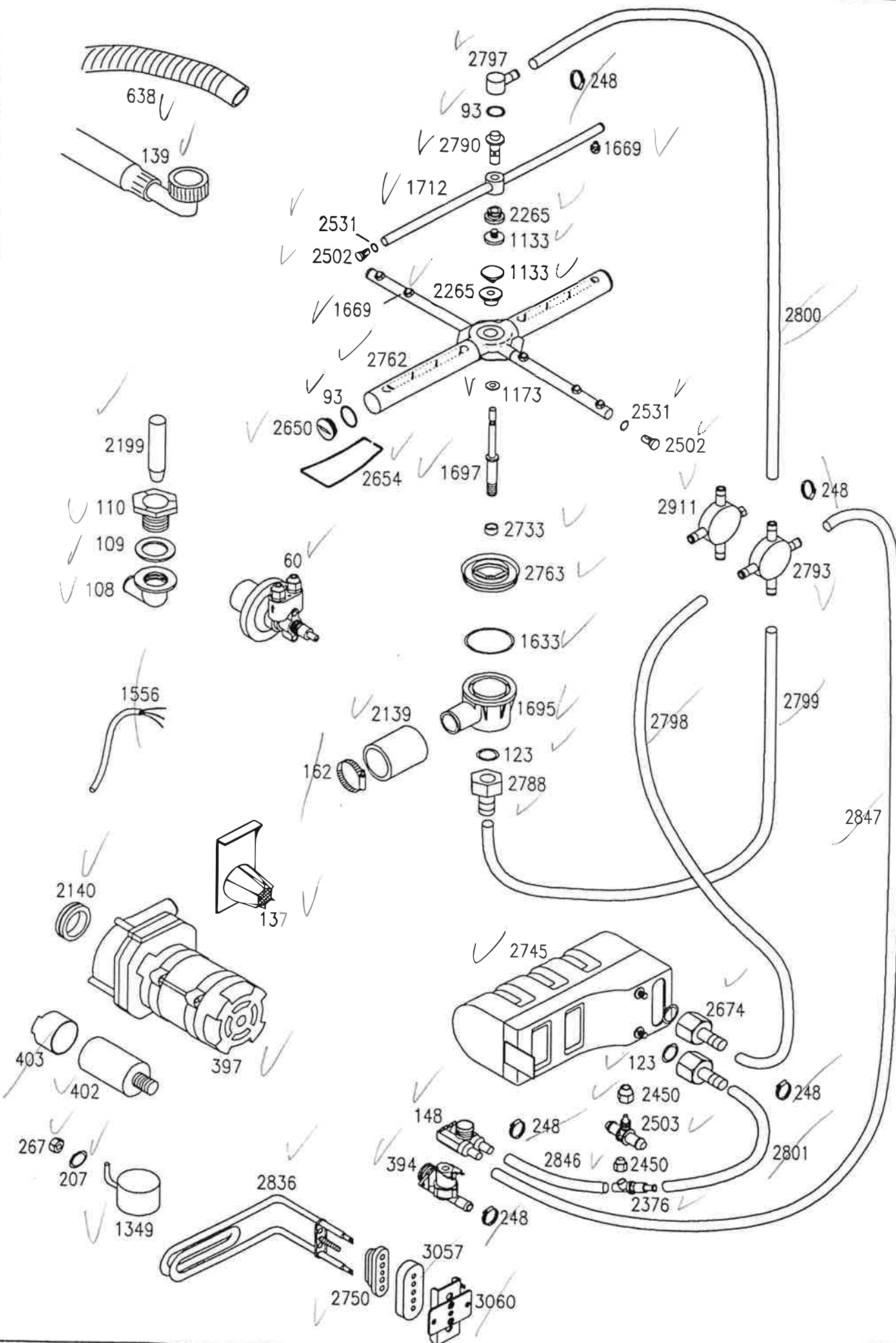

LAVABICCHIERI MASTER 21

TAVOLA
MS

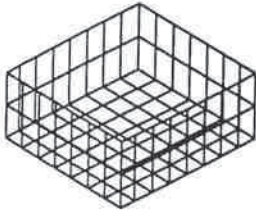
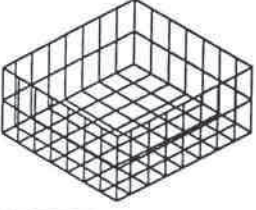
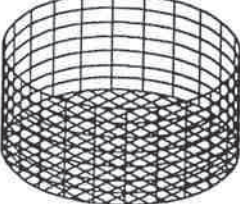
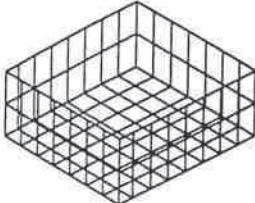
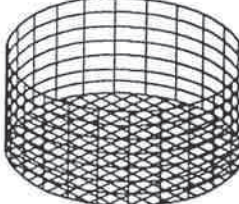
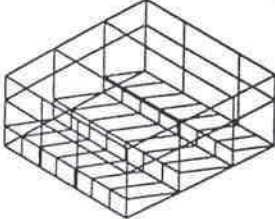
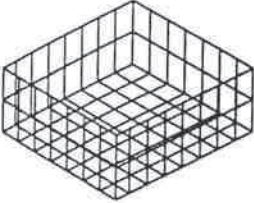

CESTI PER LAVABICCHIERI E LAVAPIATTI

TAVOLA
DO







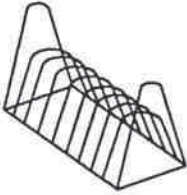
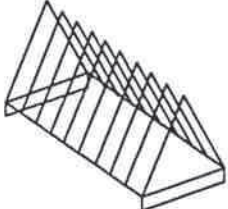
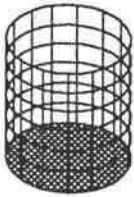
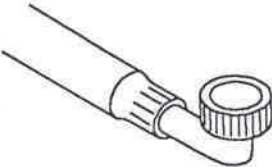
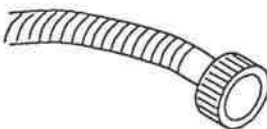
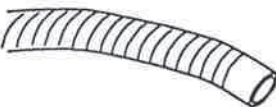
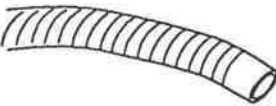

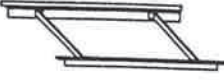
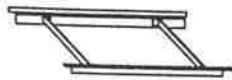
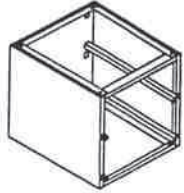
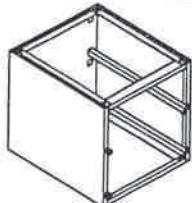
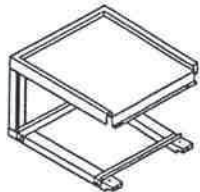

CODICE	DESCRIZIONE	CESTO	MODELLO APPARECCHIO
2461	CESTO QUADRO SENZA ANGOLARI 350x350x115 mm		COMPACT 20 MASTER 21
3065	CESTO QUADRO SENZA ANGOLARI 350x350x170 mm		COMPACT 20 MASTER 21
2554	CESTO TONDO Ø 330x180 mm		COMPACT 20 - MASTER 21 CON INSERTO INOX PER CESTO TONDO
630	CESTO QUADRO CON ANGOLARI 350x350x170 mm		MINIBAR CF - GEMINI CF PROGRAM 25 CF - IDROJET CF
195	CESTO TONDO Ø 360x180 mm		MINIBAR CR - GEMINI CR ITALJET CR - IDROJET CR SNACK CR - PROGRAM 25 CR PROJECT 28 CF CON INSERTO INOX PER CESTO TONDO
63010	CESTO QUADRO CON ANGOLARI FONDO INCLINATO A 3 DIVISORI 375x375x175 mm		MINIBAR CF - GEMINI CF PROGRAM 25 CF - IDROJET CF
63011	CESTO QUADRO CON ANGOLARI 375x375x170 mm		MINIBAR CF - GEMINI CF PROGRAM 25 CF - IDROJET CF
2814	CESTO TONDO Ø 360x240 mm		ITALJET CR - IDROJET CR SNACK CR - PROGRAM 25 CR

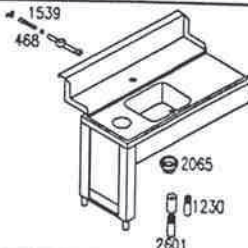
ACCESSORI IN DOTAZIONE

TAVOLA
DI

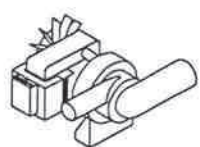
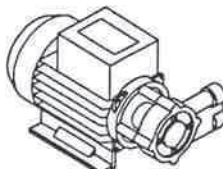
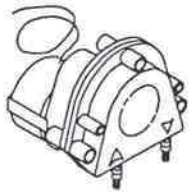
CODICE	DESCRIZIONE	CESTO	MODELLO APPARECCHIO
186	INSERTO PORTAPIATTINI A 12 POSTI		COMPACT 20 - MASTER 21 MINIBAR - GEMINI PROGRAM 25 - PROJECT 28 ITALJET - IDROJET SNACK
187	INSERTO PORTAPIATTINI A 15 POSTI		SELF 2 - SELF 4.32 GL 5.34 - GL 7.38
189	INSERTO PORTAPOSATE		IN TUTTI I MODELLI
139	CANNA DI CARICO CON CURVA 1500 mm		COMPACT 20 - MASTER 21 MINIBAR - GEMINI PROGRAM 25 - PROJECT 28 SELF 2 - SELF 4.32 GL 1040 - GL 1240
253	CANNA DI CARICO SENZA CURVA 1500 mm		SELF 4.32 GL 5.34 - GL 7.38
638	CANNA DI SCARICO Ø18x2000 mm		COMPACT 20 - MASTER 21 MINIBAR - GEMINI PROGRAM 25 - ITALJET IDROJET - SNACK
2188	CANNA DI SCARICO Ø28x2000 mm		PROJECT 28 SELF 2 - SELF 4.32 GL 500 - GL 700 GL 5.34 - GL 7.38 GL 1040 - GL 1240

OPTIONAL

INSERTO INOX PORTACESTI		CODICE	INSERTO INOX PORTACESTI		CODICE
	COMPACT 20 MASTER 21 MINIBAR-GEMINI	595190 595190 595290		PROGRAM 25 PROJECT 28 SELF 4.32	595290 595390 595490
BASAMENTO PORTACESTI		CODICE	BASAMENTO PORTACESTI		CODICE
	COMPACT 20 MASTER 21 MINIBAR GEMINI	591990 592090 592690 592690		PROGRAM 25 PROJECT 28 SELF 4.32 GL 5.34	592990 592790 592490 592390
PIANO DI SGOMBERO PER GL 1040-1240		CODICE	LAVELLO PER GL 5.34 DX-SX (CON RUBINETTO E PORTA)		CODICE
	L = 700 mm P = 566 mm H = 450 mm	590990		L = 1200 mm P = 700 mm H = 850 mm	DX 590790 SX 590890
TAVOLO PRELAVAGGIO DX-SX DA 1500 mm PER GL 1040-1240		CODICE	TAVOLO PRELAVAGGIO DX-SX DA 1200 mm PER GL 1040-1240		CODICE
	DX SX	590390 590490		DX SX	590590 590690
	GOMMA ANTIURTO PIEDE BANCALE PVC PIEDE BANCALE INOX PARTICOLARE FISSAG. DOCCIONE DADO DOCCIONE PRELAVAGGIO	2065 1230 2601 1539 468		PIEDE BANCALE PVC PIEDE BANCALE INOX PARTICOLARE FISSAG. DOCCIONE DADO DOCCIONE PRELAVAGGIO	1230 2601 1539 468
DOCCIONE COMPLETO		CODICE	PATTUMIERA CON RUOTE		CODICE
		594290			594190
POMPA DI SCARICO		CODICE	POMPA SUPPLEMENTARE		CODICE
		379			380
DOSATORE DETERSIVO		CODICE	DEPURATORE		CODICE
		1206		8 Lt. 12 Lt. 16 Lt. 20 Lt.	596190 596290 596390 596490
INSERTO PORTACALICI		CODICE	INSERTO PORTABICCHIERI INCLINATO		CODICE
		2144			2252







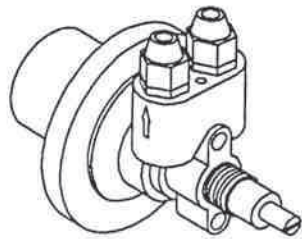





DOSATORE BRILLANTANTE

TAVOLA
DB

DOSATRON



60

- | | | | | | |
|------|---|---|---|---|------|
| 2450 | — |  |  | — | 2450 |
| 2453 | — |  |  | — | 2453 |
| 1136 | — |  |  | — | 1136 |
| 2245 | — |  | | | |
| 2217 | — |  |  | — | 634 |
| 2504 | — |  | | | |
| 2446 | — |  |  | — | 2560 |

- | | |
|------|-----------------------|
| 1136 | OR 3056 |
| 2217 | SFERA 3/8 INOX |
| 2245 | MOLLA CONICA INOX |
| 2446 | OR 2025 |
| 2450 | SERRATUBO |
| 2453 | TAPPO VALVOLA |
| 2504 | DISTANZIATORE |
| 634 | VALVOLA A LABBRO |
| 2560 | SEDE VALVOLA A LABBRO |

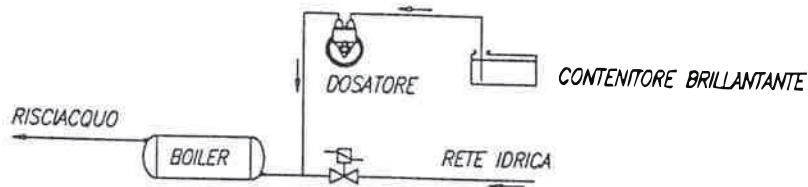
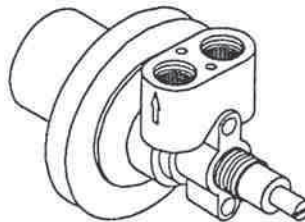

SCHEMA DI COLLEGAMENTO

DOSATORE BRILLANTANTE "DOSATRON"

CARATTERISTICHE TECNICHE

FUNZIONAMENTO: utilizza la pressione di risciacquo della macchina.

COLLEGAMENTO IDRICO: utilizzare la cannucchia installata nella macchina per collegare il dosatore lato "freccia uscita" all'impianto di risciacquo della lavastoviglie nel tratto compreso fra l'elettrovalvola e il boiler. Con la cannucchia in dotazione collegare il dosatore lato "freccia entrata" al contenitore di brillantante.

FISSAGGIO MECCANICO: utilizzare il dado in dotazione. N.B. il dosatore puo' avere qualsiasi orientamento di montaggio.

INNESCO: procedere nel seguente modo: svitare la vite di regolazione fino all'arresto, quindi spingerla all'interno piu' volte affinche' il brillantante aspirato riempi entrambe le cannuce.

REGOLAZIONE: ad ogni risciacquo inietta una quantita' di brillantante regolabile da 0 a 4 cm³, equivalente ad una lunghezza aspirata della cannucchia da 0 a 30 cm. La portata nulla si ha avvitando completamente la vite di regolazione (senso orario), mentre la portata massima si ottiene con la vite svitata di circa 13 giri (senso antiorario). Per ogni giro della vite la dose varia di 2cm aspirati in cannucchia (0.3 cm³/giro).