

## Shell assembly Mod. MUSTER 350

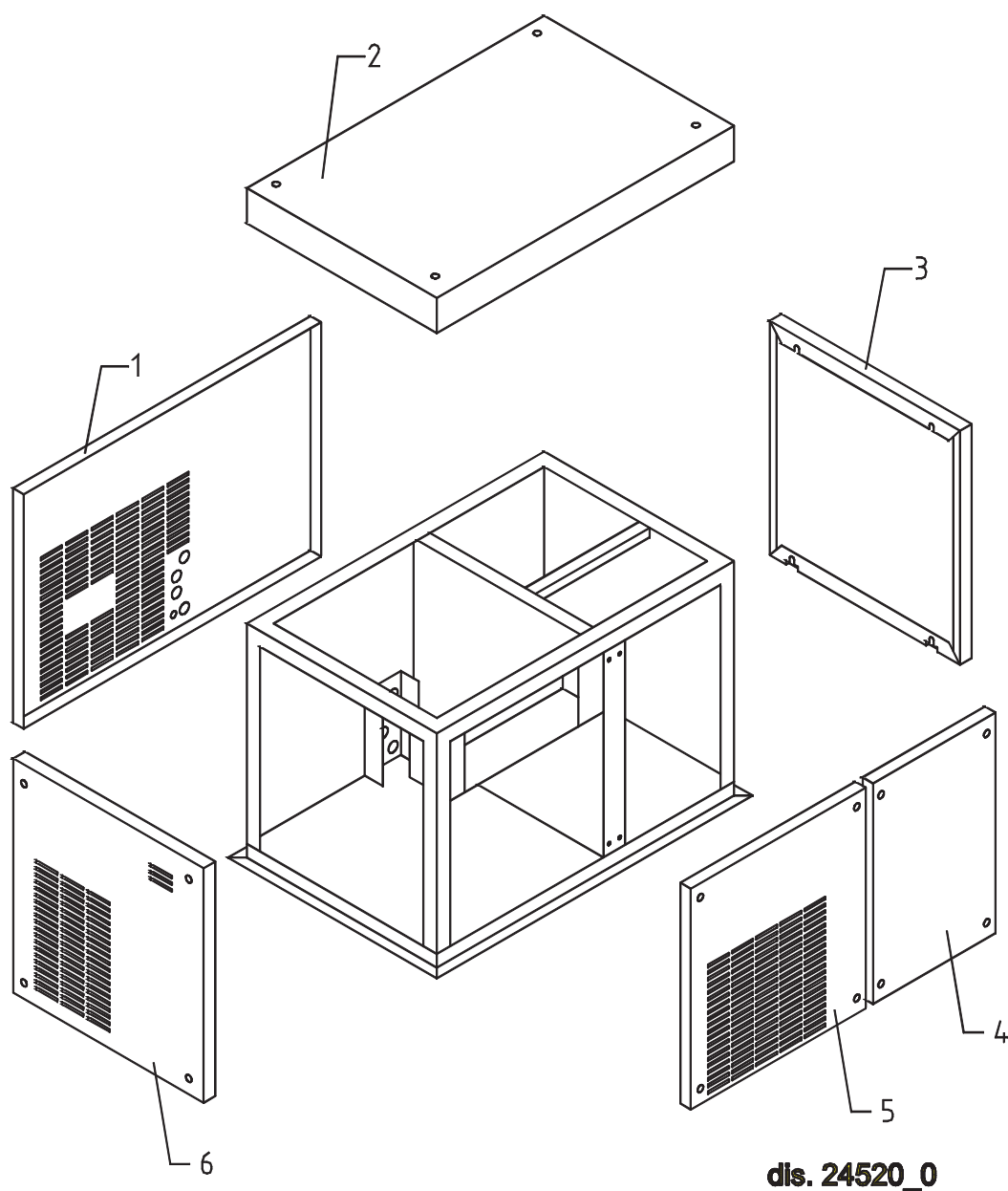

**Shell assembly Mod. MUSTER 350 (TAB. 74)**

Ref.	Description	Refrigerant	A/W	Tension	Code
1	Rear panel				22427
2	Top assy				C22422
3	Right side				22425
4	Front panel assy (evaporator side)				C22424B
5	Front panel condenser side				C22423
6	Left side				22426

# Cooling system assembly Mod. MUSTER 350-800

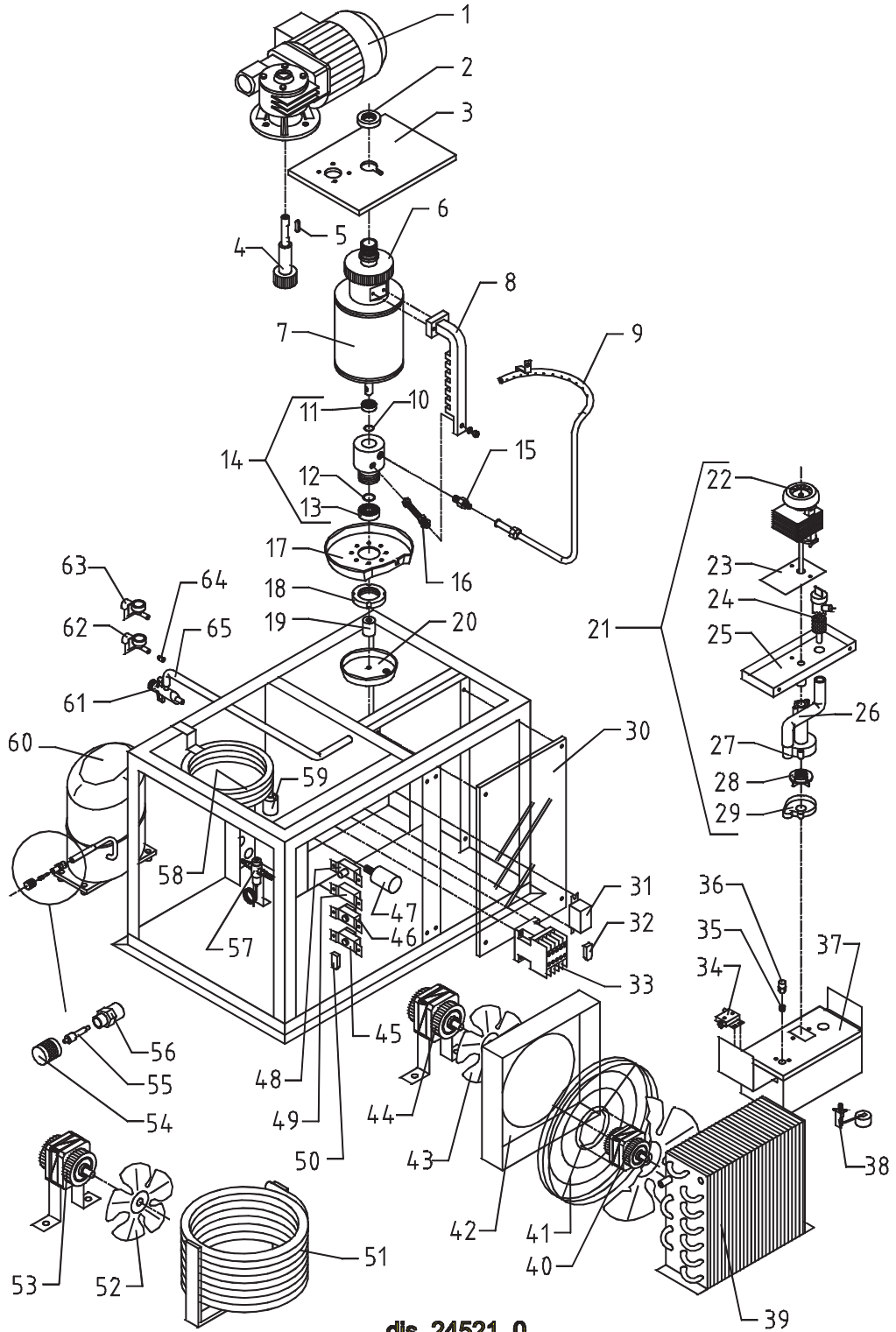

dls. 24521\_0

**Cooling system assembly Mod. MUSTER 350 (TAB. 78)**

<b>Ref.</b>	<b>Description</b>	<b>Refrigerant</b>	<b>A/W</b>	<b>Tension</b>	<b>Code</b>
1	Gearmotor assy				C23363
2	Ring nut for cylinder locking				20324
3	Support evaporator plate				20356
4	Pinion with shaft for gearmotor				20344
5	Key 6x6x40				20350
6	Crown gear				20354
7	Evaporator				C11059
8	Knife				E20330
9	Spray ring				C20319
11	Upper inox bearing				20531
12	Silicone OR 4081 ring				20338
13	Inox bearing				20045
14	Complete rotary ring				C10180
15	Joint				20335
16	M8 tie rod (to block knife)				20329
17	Rotary basin				10184
18	Ring nut for rotary ring				10182
19	Spacer				20321
20	Fixed basin				C10185
21	Pump and filter assy			1-4-5	C26557
21	Pump and filter assy			2-6	C26712
22	Pump motor			1-4-5	23073
22	Pump motor			2-6	23187
23	Heat dissipator				22430
24	Filtering element				20254
25	Pump motor holder				10161
26	Pump-filter fitting pipe				13084
27	Pump body				10065
28	Pump impeller				10138
29	Diffuser				10067
30	Screen evaporator chamber				10187
31	Relay				23190
32	Anti radio interference filter			1-5	23458
33	Contactora				23147
34	Microswitch for overflow ice				23373
35	Bush				20405
36	Nut				20404
37	Pump water basin				C22419
38	Floating valve				10188
39	Air condenser		*		20426
42	Conveyor		*		10238
43	Suction fan 275-34°		*		20153
44	Fan motor		*		23121
45	Bin thermostat				23005
46	Safety thermostat				23447
48	Pressure switch (maximum pressure)				23342
49	Condenser pressure switch		*		23175
50	Anti radio interference filter		*	1-5	23459
51	Water condenser		W		14285
52	Suction fan		W		20095
53	Fan motor		W		23029
54	Vacuum-charge valve plug				14006
55	Vacuum-charge valve device				14005

56	Vacuum- charge valve body				14007
57	Pressure valve				20149
58	Water condenser		*		14014
59	Solid core drier				14084
60	Compressor			1	23514
60	Compressor			2	23515
60	Compressor			5	23516
60	Compressor			4-6	23564
61	Discharges manifold				C10052
62	1 way inlet water nipple		*		10239
63	1 way inlet water nipple				10239
64	Flow control lt.1,2 for inlet water connector		*		10011
65	Overflow pipe				13082

**4.Note:** 4. Code 20344 from number 47869.

11. Code 20531 from number 95180.

39. Code 20148 (\*) until number 43383. Code 20426 (\*) from number 43384.

42. Code 10238 (\*) from number 43384.

60. Code 23448 (Refr R22-R404A, Tens.1) until number 34204. Code 23514 (Tens.1) from number 34205.

Code 23460 (Refr R22-R404A, Tens.2) until number 33908. Code 23515 (Tens.2) from number 33909. Code

23450 (Refr R22-R404A, Tens.5) until number 34204. Code 23516 (Tens.5) from number 34205.

Pinion gear (Code 20344) is an only part and it can be changed with previous version formed by pinion, shaft and safety pin, but only if the gearmotor has the safety klikson.

7.The Evaporator Assembly (Code C11059) includes also the items at the position no. 2,8,11,12,13,14,16,19.

\*.It is valid only for models A-W.