

PIN CANWASHER

ELECTRONICAL SWITCHES
LOWER AND UPPER WASHER

TYPE: 85S

Accessories
DVGW VALVE SYSTEM
BOOSTER PUMP

Spare parts Manual



INFORMAZIONI GENERALI

Questo catalogo serve per richiedere con esattezza le parti di ricambio

Nelle ordinazioni indicare:

1) il numero dei codici dei particolari seguito dalla descrizione e la quantità desiderata;

2) Il codice alfa-numerico presente nella seconda colonna della tabella ;

I disegni delle parti di ricambio sono solo indicativi e non rappresentano il pezzo in oggetto.

I dati contenuti in questo catalogo sono indicativi e possono essere soggetti a modifiche senza impegno di preavviso.

ALLGEMEINE INFORMATIONEN

Dieser Ersatzteilkatalog dient zur genauen Angabe der Teile bei Ersatzteilbestellungen.

Bei Ersatzbestellung ist folgendes anzugeben:

1) Die Bestellnummer der Ersatzteile mit der entsprechenden Beschreibung genaue Menge;

2) Der alpha-numerischer Code auf der zweiten Reihe in dein Spalte;

Die Zeichnungen der Ersatzteile sind nur als Hinweise gedacht und stellen nicht das betroffene Teil dar.

Bei den im Katalog angeführten Daten handelt es sich um Anhaltsdaten, die jederzeit, ohne Vorankündigung, geändert werden können.

GENERAL INFORMATION

The present spare parts order exactly the right spare parts

When ordering specify:

1) the part's code number followed by its description and quantity needed;

2) The alpha-numeric code is in the second column in the chart;

Spare parts drawings are general and do not represent the part.

The contents of this catalogue are general and can undergo changes without prior notice.

INFORMACIONES GENERALES

El presente catálogo sirve para pedir con exactitud las partes de repuesto

En los pedidos se debe indicar:

1) el número de código de la parte y a continuación la descripción cantidad deseada;

2) El código alfanumerico presente en la signada columna de la tabla;

Los diseños de las partes de recambio son solo indicativos y no representan la pieza en cuestión.

Los datos contenidos en el presente catálogo son indicativos y pueden modificarse sin aviso previo.

INFORMATIONS GENERALES

Ce catalogue permet de commander correctement les pièces détachées

Les commandes doivent être passées en indiquant:

1) le numero de code des pièces détachées suivi de leur description quantité désirée;

2) le code alphanumérique dans la deuxième colonne du tableau;

Les plans des pièces détachées sont fournis seulement à titre indicatif et ne représentent pas la pièce concernée.

Les données de ce catalogue sont citées seulement à titre indicatif et peuvent être l'objet de modifications sans avis préalable.

ESEMPIO
EXAMPLE
EXEMPLE
BEISPIEL

Rif.	Codici
MODULE:Particolari	
10505	540903
10510	540908
10515	15065/A
10520	540086
10525	540028



Note

Tutte le informazioni riportate si intendono aggiornate alla data di stampa. Il Produttore si riserva il diritto di apportare qualsiasi modifica richiesta dallo sviluppo evolutivo dei suddetti prodotti.

Per la sicurezza, la garanzia, l'affidabilità ed il valore della lavastoviglie usa solo ricambi originali. **Per alcuni codici, sono richieste quantità minime d'ordine.**



Attenzione

Questo libretto è parte integrante della lavastoviglie e, in caso di passaggio di proprietà, deve essere consegnato al nuovo acquirente.



Remarque

Toutes les informations contenues dans ce manuel s'entendent mises à jour à la date d'impression. En raison du développement constant de ses produits, usine se réserve le droit d'apporter à tout instant les modifications qu'elle jugera utiles.

Pour la sécurité, la garantie, la fiabilité et la valeur de votre lave-vaisselles n'utilisez que des pièces de rechange d'origine. **Pour quelque référence on demande un minimum de pièces par commande**



Attention

Ce manuel doit être considéré comme partie intégrante de la lave-vaisselles, en cas de transfert de propriété, doit toujours être remis au nouveau propriétaire.



Note

The information contained herein is valid at the time of going to print. The Company reserves the right to make any changes required by the future development of the above-mentioned products.

For your safety, as well as to preserve the warranty reliability and worth of your dishwashers, use original spare parts only. **For some codes a minimum quantity for order is required.**



Warning

This manual forms an integral part of the dishwashers and - if a transfer of title occurs - must always be handed over to the new owner.



Hinweis

Die Der Hersteller behält sich das Recht vor, jegliche, durch eine Weiterentwicklung der genannten Produkte bedingte Änderungen vornehmen zu können.

Verwenden Sie für Ihre Sicherheit, die Garantie, die Zuverlässigkeit und den Wert Ihrer machine originale Ersatzteile. **Für bestimmte Code nummer werden mindesten bestellungen verlangt.**



Achtung

Diese Betriebsanleitung ist Bestandteil des machine und muss bei seinem Weiterverkauf dem neuen Besitzer ausgehändigt werden.



Code DW 999XXXXXX **CL/Part**

Model DESCRIPTION

S/N DW A 1015770 **Type**

400V 3N 50HZ 8A
3500W 500W

  16A

200-500 kPa

Pressione Dinamica alimentazione idrica
Pression dynamique arrivee d'eau
Dynamic pressure water supply
Dynamischer Druck asserreinlauf

Pressione dinamica vapore saturo
Pression dynamique vapeur satuee
Dymanischer Druck gesattigter Dampf
Pression Dinamica Vapor Saturado

TECHICAL SPECIFICATION



MADE IN ITALY

Temperatura massima acqua in ingresso 60°C
Temperature max eau a l'entre
Maximale Temperatur Wasseranschlu
Maximum Water temperature in-feeding



Model 

S/N 



1. Spare parts

- Electric parts..... 9**
- General parts 11**
- Economizer components 13**
- Curtains group components 15**
- Electric control components..... 17**
- Solenoid valve group 19**
- DVGW valve 21**
- Entry shelf components 23**
- Exit shelf components 25**
- Pre-rinsing system components..... 29**
- Rinsing system components..... 31**
- Internal components 33**
- Chain components 35**
- Closing panels 37**
- Booster pump..... 39**
- Accessory..... 41**

1.1 Voltage codes

Volt	Voltage code
A	3/N/PE~380-400V 50-60Hz
D	3/PE~200-210V 50-60Hz
F	2/PE~220-240V 50-60Hz
G	3/N/PE~415V 50-60Hz
H	3/PE~220-230V 50-60Hz
K	3/PE~380-400V 50-60Hz
L	3/PE~415V 50-60Hz
M	3/PE~440V 60Hz
P	1/N/PE~220-230V 50-60Hz
R	2/PE~220-240V 50-60Hz
U	1/N/PE~240V 50-60Hz
V	3/PE~240V 50-60Hz
W	1/N/PE~100-110V 50-60Hz

1.2 Product codes

Product code	Full name
Model codes	
e	ELECTRONICAL SWITCHES
uw	LOWER AND UPPER WASHER
Type codes	
85S	85S
Accessory codes	
dvgw	DVGW VALVE SYSTEM
bp	BOOSTER PUMP

02_003xe

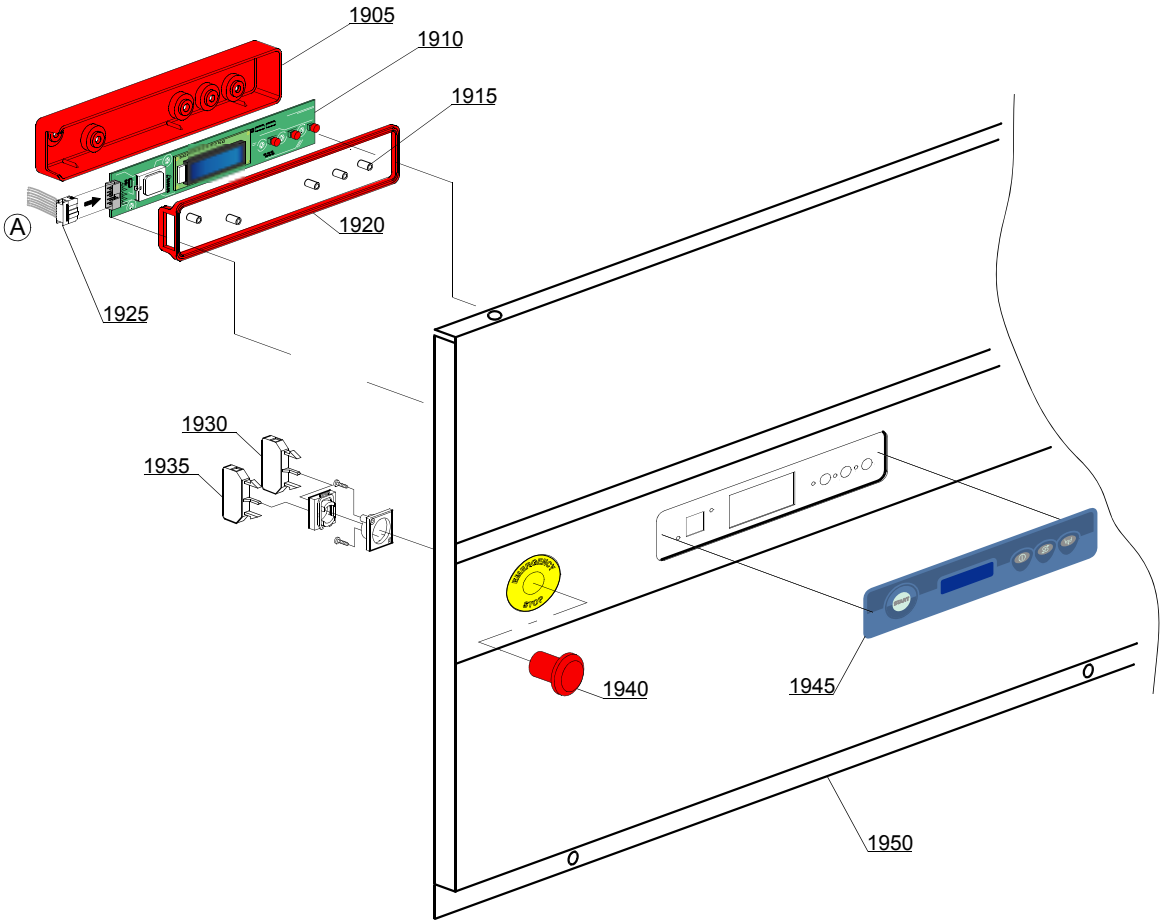

Spare parts

ID	P-code	SN from	SN to	Mod.	Acces.	Volt	Description
Module:Electric parts [UX-110,BB 1100]							
1905	560051/A		-	e,uw		A	Protective cover for board
1910	560051		-	e,uw		A	Complet membrane push button-driver
1915	50561		-	e,uw		A	Board spacer
1920	560051/B		-	e,uw		A	Gaskets for protective cover
1925	50651		-	e,uw		A	Plug
1930	3002054		-	e,uw		A	Green contact piece (NO)
1935	3002056		-	e,uw		A	Red contact piece (NC)
1940	3002050		-	e,uw		A	Emergency button
1945	560048		-	e,uw		A	Silkscreen processed grill membrane push button-driver
1950	3020514		-	e,uw		A	Front cover

e=ELECTRONICAL SWITCHES, uw=LOWER AND UPPER WASHER

85S=85S

dvgw=DVGW VALVE SYSTEM, bp=BOOSTER PUMP

A=3/N/PE~380-400V 50-60Hz, D=3/PE~200-210V 50-60Hz, F=2/PE~220-240V 50-60Hz, G=3/N/PE~415V 50-60Hz, H=3/PE~220-230V 50-60Hz, K=3/PE~380-400V 50-60Hz, L=3/PE~415V 50-60Hz, M=3/PE~440V 60Hz, P=1/N/PE~220-230V 50-60Hz, R=2/PE~220-240V 50-60Hz, U=1/N/PE~240V 50-60Hz, V=3/PE~240V 50-60Hz, W=1/N/PE~100-110V 50-60Hz

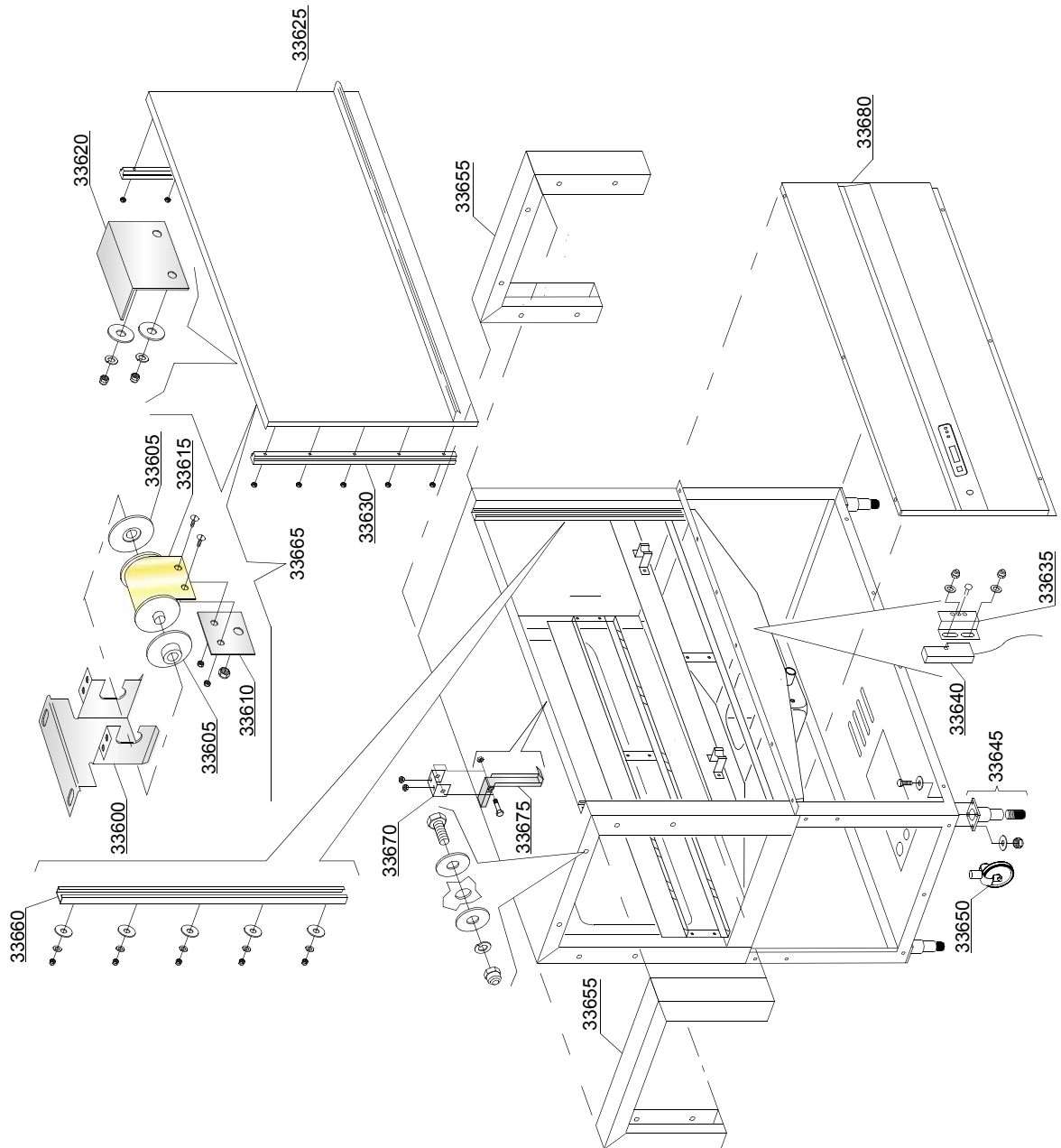

03_026x6

Spare parts

ID	P-code	SN from	SN to	Mod.	Acces.	Volt	Description
Module:General parts [UX-110,BB 1100]							
33600	3009664		-	uw			Spring support
33605	3004012		-	uw			Spring holder
33610	3009555		-	uw			Spring clamping plate
33615	3004010		-	uw			Door spring BBSR 21
33620	3009269		-	uw			Door stop
33625	3009403		-	uw			Door assembly
33630	3004026		-	uw			Door guide
33635	3009112		-	uw			Microswitch support
33640	3003112		-	uw			Door microswitch
33645	80116		-	uw			Foot
33650	999900509		-	uw			Wheels kit
33655	3020004		-	uw			Splash zone
33660	3009033		-	uw			Slideways
33665	3009907		-	uw			Spring assembly BBSR 21
33670	3000324		-	uw			Hook support
33675	3000323		-	uw			Hook door
33680	3020514		-	uw			Front cover

e=ELECTRONICAL SWITCHES, uw=LOWER AND UPPER WASHER

85S=85S

dvgw=DVGW VALVE SYSTEM, bp=BOOSTER PUMP

A=3/N/PE~380-400V 50-60Hz, D=3/PE~200-210V 50-60Hz, F=2/PE~220-240V 50-60Hz, G=3/N/PE~415V 50-60Hz, H=3/PE~220-230V 50-60Hz, K=3/PE~380-400V 50-60Hz, L=3/PE~415V 50-60Hz, M=3/PE~440V 60Hz, P=1/N/PE~220-230V 50-60Hz, R=2/PE~220-240V 50-60Hz, U=1/N/PE~240V 50-60Hz, V=3/PE~240V 50-60Hz, W=1/N/PE~100-110V 50-60Hz

03_104xe

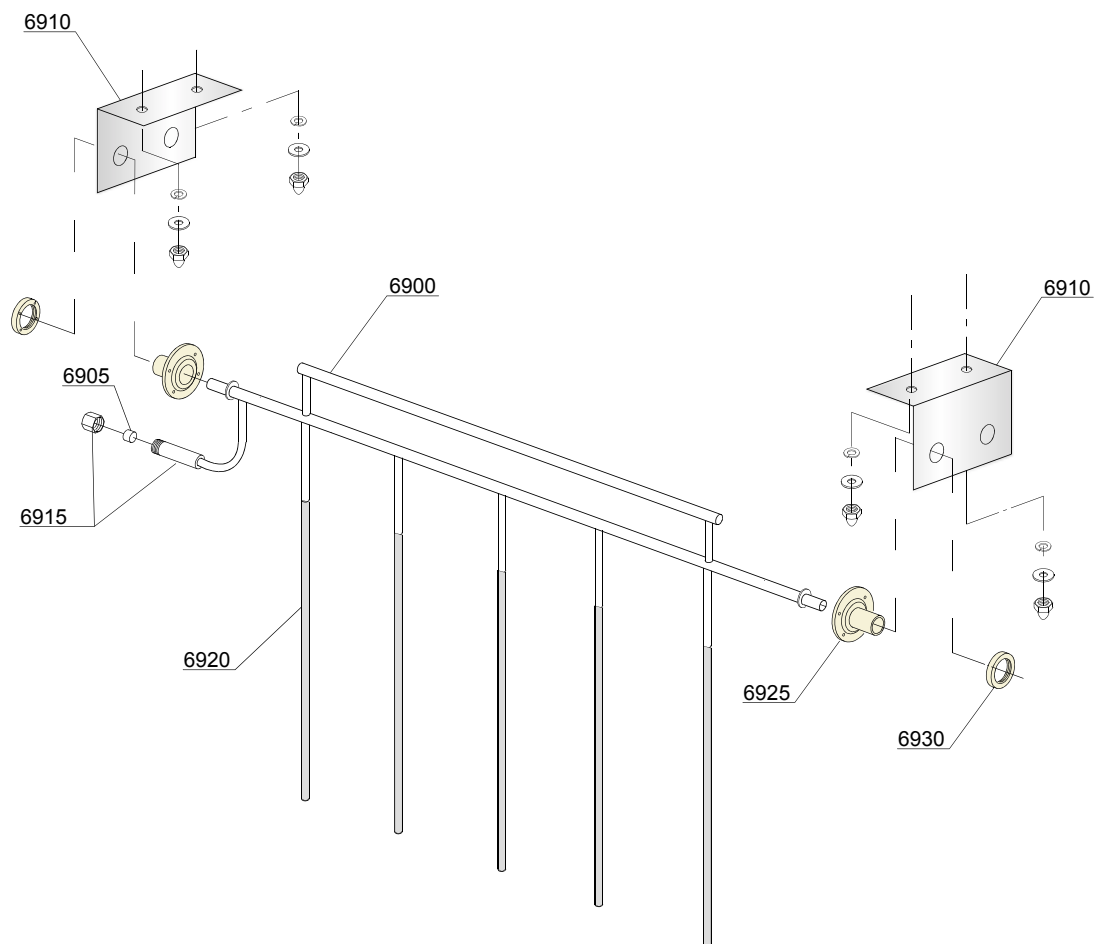

VALIDO PER VERSIONI DX E SX
VALID FOR EITHER RIGHT OR LEFT VERSION
VALABLE POUR VERSION DROITE ET GAUCHE

Spare parts

ID	P-code	SN from	SN to	Mod.	Acces.	Volt	Description
Module: Economizer components [UX-110, BB 1100]							
6900	3020525		-	e,uw			Bar economizer support
6905	3003113		-	e,uw			Magnet
6910	3020527		-	e,uw			Economizer support
6915	3060065		-	e,uw			Magnet holder
6920	3060159		-	e,uw			Economizer bar
6925	75320		-	e,uw			Holder
6930	75317		-	e,uw			Nut

e=ELECTRONICAL SWITCHES, uw=LOWER AND UPPER WASHER

85S=85S

dvgw=DVGW VALVE SYSTEM, bp=BOOSTER PUMP

A=3/N/PE~380-400V 50-60Hz, D=3/PE~200-210V 50-60Hz, F=2/PE~220-240V 50-60Hz, G=3/N/PE~415V 50-60Hz, H=3/PE~220-230V 50-60Hz, K=3/PE~380-400V 50-60Hz, L=3/PE~415V 50-60Hz, M=3/PE~440V 60Hz, P=1/N/PE~220-230V 50-60Hz, R=2/PE~220-240V 50-60Hz, U=1/N/PE~240V 50-60Hz, V=3/PE~240V 50-60Hz, W=1/N/PE~100-110V 50-60Hz

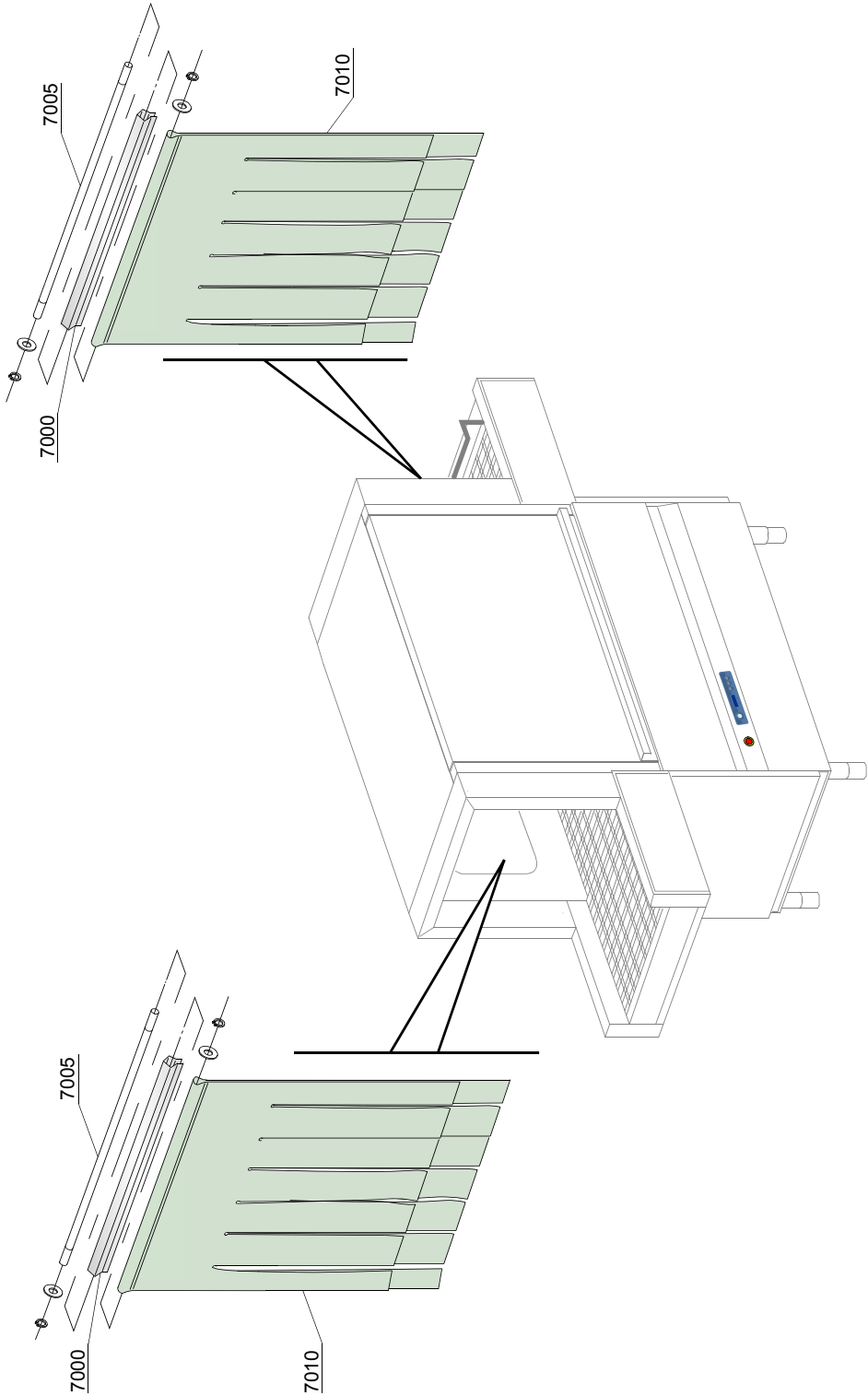

03_201xe

Spare parts

ID	P-code	SN from	SN to	Mod.	Acces.	Volt	Description
Module: Curtains group components [UX-110, BB 1100]							
7000	3009109		-	e,uw			Curtain moulding
7005	3004053		-	e,uw			Curtain rod long
7010	3004052		-	e,uw			Curtain long

e=ELECTRONICAL SWITCHES, uw=LOWER AND UPPER WASHER

85S=85S

dvgw=DVGW VALVE SYSTEM, bp=BOOSTER PUMP

A=3/N/PE~380-400V 50-60Hz, D=3/PE~200-210V 50-60Hz, F=2/PE~220-240V 50-60Hz, G=3/N/PE~415V 50-60Hz, H=3/PE~220-230V 50-60Hz, K=3/PE~380-400V 50-60Hz, L=3/PE~415V 50-60Hz, M=3/PE~440V 60Hz, P=1/N/PE~220-230V 50-60Hz, R=2/PE~220-240V 50-60Hz, U=1/N/PE~240V 50-60Hz, V=3/PE~240V 50-60Hz, W=1/N/PE~100-110V 50-60Hz

04_021xe

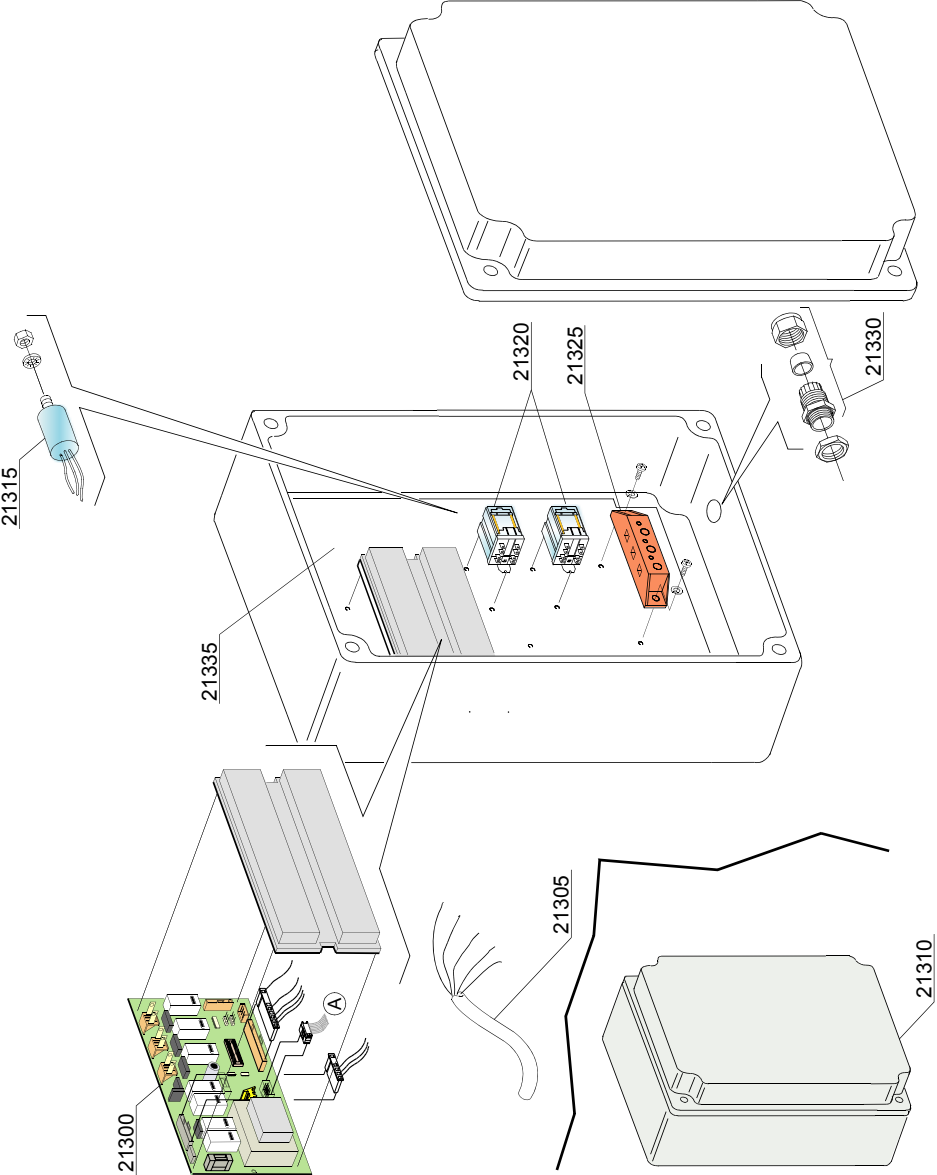

Spare parts

ID	P-code	SN from	SN to	Mod.	Acces.	Volt	Description
Module:Electric control components [UX-110,BB 1100]							
21300	3020536		-	e,uw			Main board
21305	10713		-	e,uw			3x2,5x2500 cable
21310	3020535		-	e,uw			Electric components box
21315	15149		-	e,uw			Low noise filter F3 (0,3mF)
21320	15620		-	e,uw			16A bipolar relay in deviation
21325	500550		-	e,uw			3 poles terminal board
21330	10300412		-	e,uw			Fairlead PG13
21335	3020518		-	e,uw			Electric components panel

e=ELECTRONICAL SWITCHES, uw=LOWER AND UPPER WASHER

85S=85S

dvgw=DVGW VALVE SYSTEM, bp=BOOSTER PUMP

A=3/N/PE~380-400V 50-60Hz, D=3/PE~200-210V 50-60Hz, F=2/PE~220-240V 50-60Hz, G=3/N/PE~415V 50-60Hz, H=3/PE~220-230V 50-60Hz, K=3/PE~380-400V 50-60Hz, L=3/PE~415V 50-60Hz, M=3/PE~440V 60Hz, P=1/N/PE~220-230V 50-60Hz, R=2/PE~220-240V 50-60Hz, U=1/N/PE~240V 50-60Hz, V=3/PE~240V 50-60Hz, W=1/N/PE~100-110V 50-60Hz

05_003xe

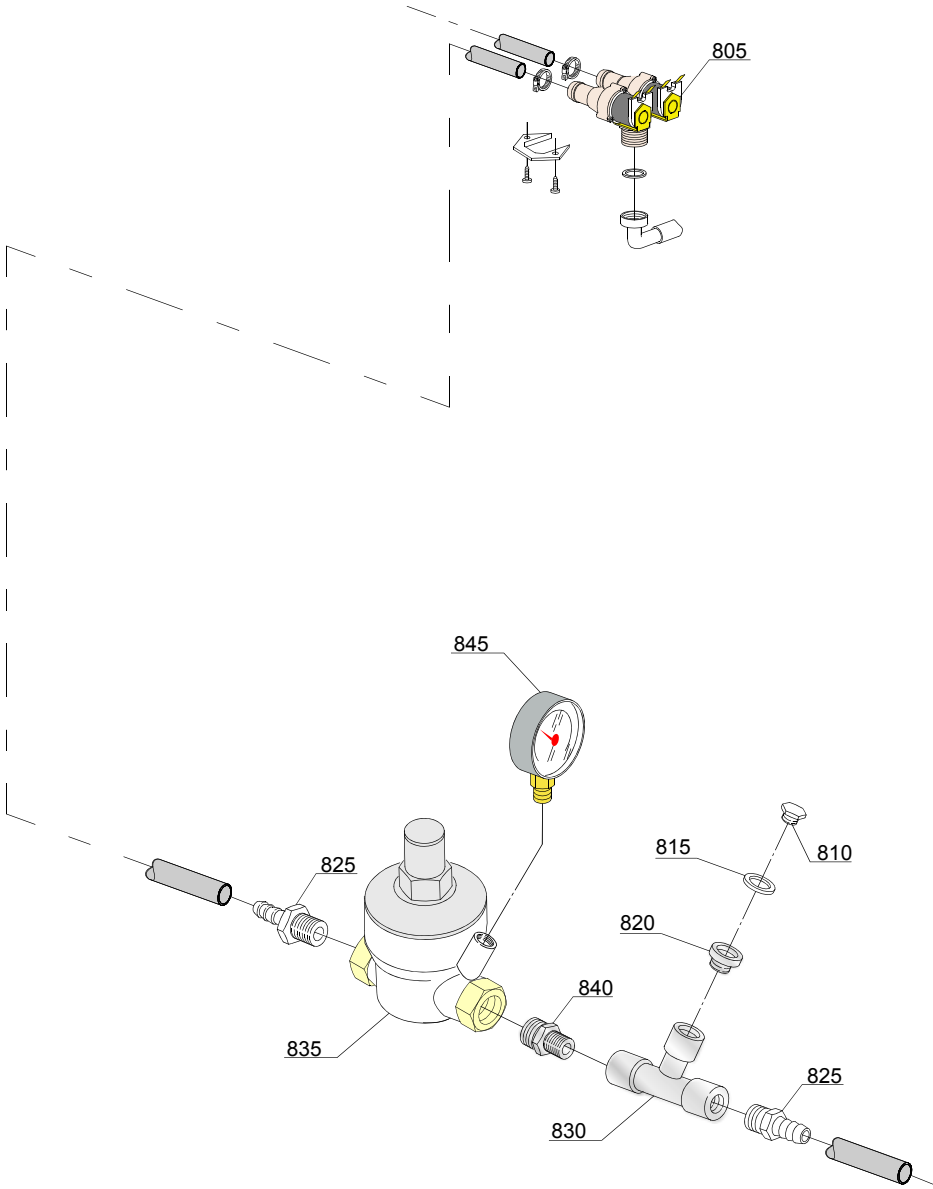

Spare parts

ID	P-code	SN from	SN to	Mod.	Acces.	Volt	Description
Module:Solenoid valve group [UX-110,BB 1100]							
805	2000094		-	e,uw			Double solenoid valve - Ø14 3/4"
810	12002		-	e,uw			Plug
815	13309		-	e,uw			Gasket 14x10x1,5
820	12032		-	e,uw			Rduction nipples
825	12005		-	e,uw			Hose holder
830	12008		-	e,uw			Connection "T"
835	391025		-	e,uw			Pressure reduction valve
840	12033		-	e,uw			1/4M - 1/2 Reduction nipples
845	2000244		-	e,uw			Pressure reduction gauge

e=ELECTRONICAL SWITCHES, uw=LOWER AND UPPER WASHER

85S=85S

dvgw=DVGW VALVE SYSTEM, bp=BOOSTER PUMP

A=3/N/PE~380-400V 50-60Hz, D=3/PE~200-210V 50-60Hz, F=2/PE~220-240V 50-60Hz, G=3/N/PE~415V 50-60Hz, H=3/PE~220-230V 50-60Hz, K=3/PE~380-400V 50-60Hz, L=3/PE~415V 50-60Hz, M=3/PE~440V 60Hz, P=1/N/PE~220-230V 50-60Hz, R=2/PE~220-240V 50-60Hz, U=1/N/PE~240V 50-60Hz, V=3/PE~240V 50-60Hz, W=1/N/PE~100-110V 50-60Hz

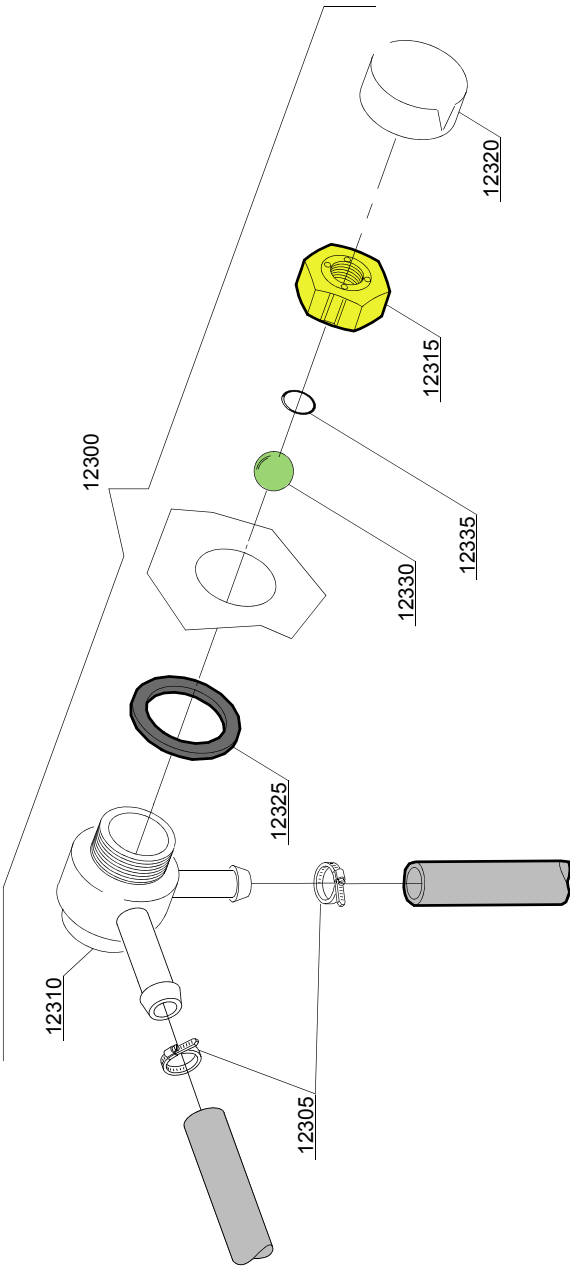

22_002ae

Spare parts

ID	P-code	SN from	SN to	Mod.	Acces.	Volt	Description
Module:DVGW valve [UX-110,BB 1100]							
12300	9891710		-	e,uw			DVGW valvola assembly
12305	11807		-	e,uw			Clamp aisi430 12/22
12310	15280		-	e,uw			Valve body center
12315	15281		-	e,uw			Flat valve
12320	15282		-	e,uw			Flat valve cover
12325	15283		-	e,uw			Valve gasket
12330	15284		-	e,uw			Sphere
12335	15285		-	e,uw			O-ring 115 KTW

e=ELECTRONICAL SWITCHES, uw=LOWER AND UPPER WASHER

85S=85S

dvgw=DVGW VALVE SYSTEM, bp=BOOSTER PUMP

A=3/N/PE~380-400V 50-60Hz, D=3/PE~200-210V 50-60Hz, F=2/PE~220-240V 50-60Hz, G=3/N/PE~415V 50-60Hz, H=3/PE~220-230V 50-60Hz, K=3/PE~380-400V 50-60Hz, L=3/PE~415V 50-60Hz, M=3/PE~440V 60Hz, P=1/N/PE~220-230V 50-60Hz, R=2/PE~220-240V 50-60Hz, U=1/N/PE~240V 50-60Hz, V=3/PE~240V 50-60Hz, W=1/N/PE~100-110V 50-60Hz

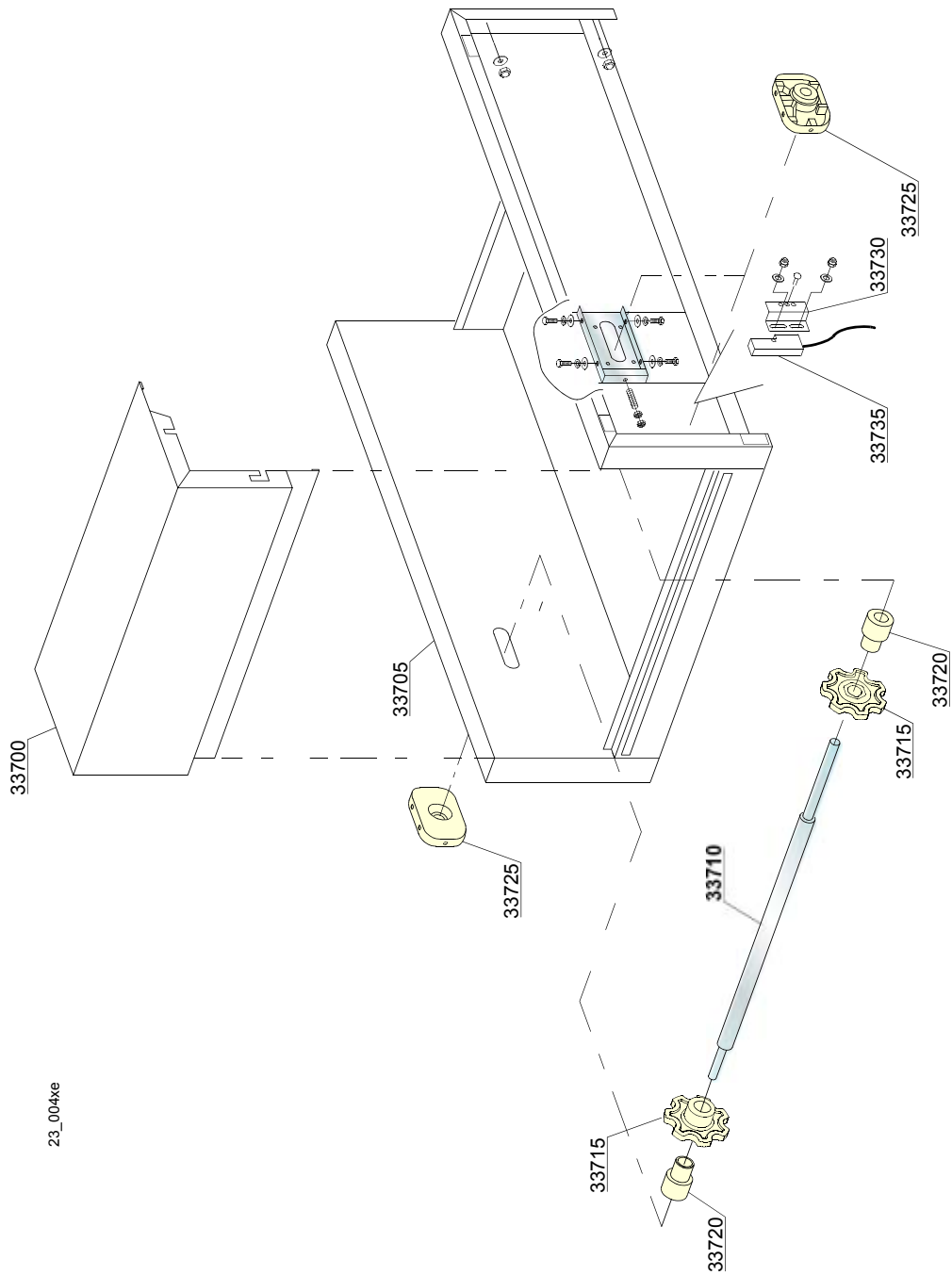

23_004xe

Spare parts

ID	P-code	SN from	SN to	Mod.	Acces.	Volt	Description
Module:Entry shelf components [UX-110,BB 1100]							
33700	3020510		-	uw			Bracket door
33710	3020107		-	uw			Neutral shaft
33715	3060134		-	uw			Neutral wheel
33720	3060135		-	uw			Neutral wheel bushing
33725	3060128		-	uw			Idle shaft support
33730	3009112		-	uw			Support reed
33735	3003112		-	uw			Safety door reed

e=ELECTRONICAL SWITCHES, uw=LOWER AND UPPER WASHER

85S=85S

dvgw=DVGW VALVE SYSTEM, bp=BOOSTER PUMP

A=3/N/PE~380-400V 50-60Hz, D=3/PE~200-210V 50-60Hz, F=2/PE~220-240V 50-60Hz, G=3/N/PE~415V 50-60Hz, H=3/PE~220-230V 50-60Hz, K=3/PE~380-400V 50-60Hz, L=3/PE~415V 50-60Hz, M=3/PE~440V 60Hz, P=1/N/PE~220-230V 50-60Hz, R=2/PE~220-240V 50-60Hz, U=1/N/PE~240V 50-60Hz, V=3/PE~240V 50-60Hz, W=1/N/PE~100-110V 50-60Hz

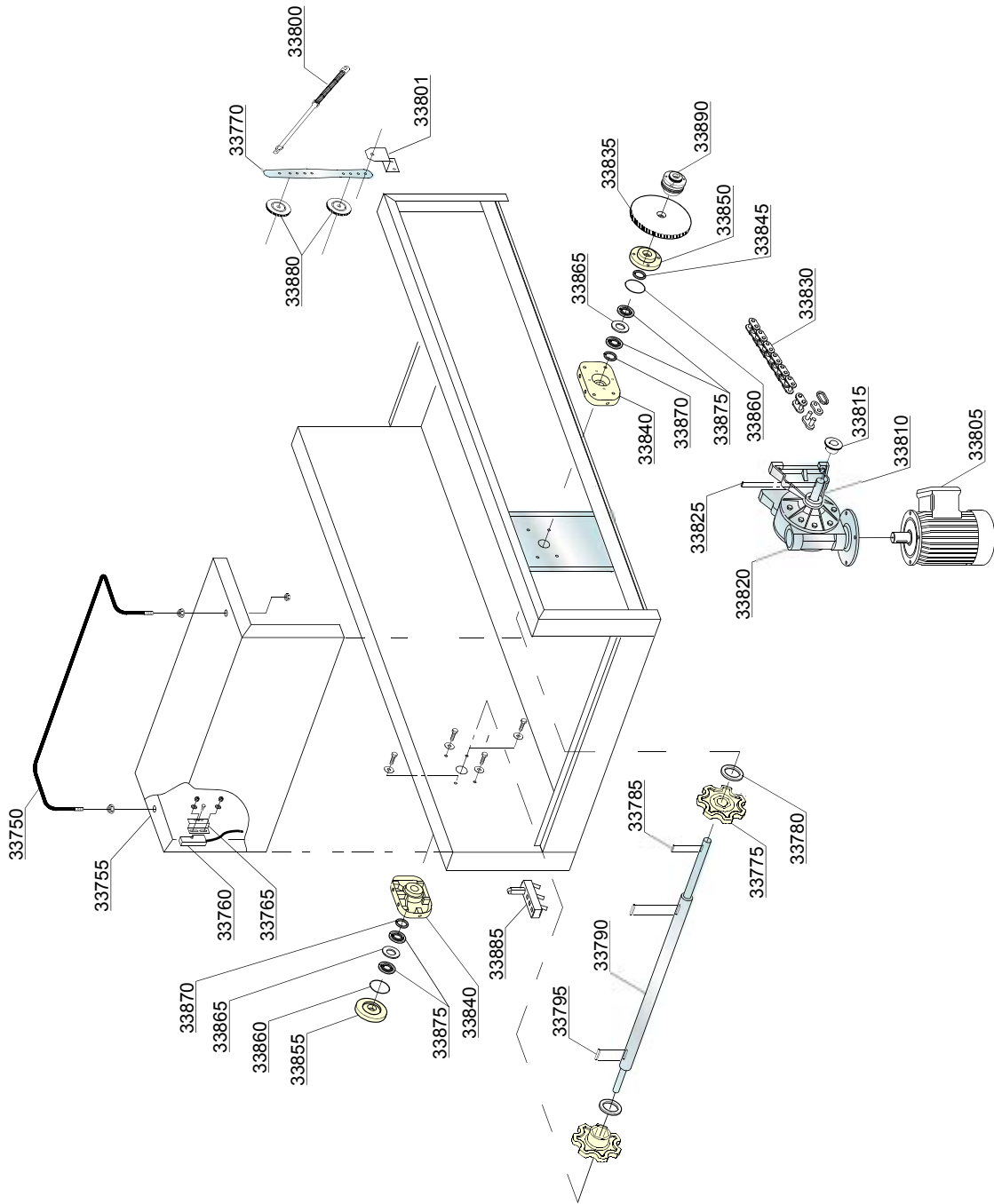

23_005xe

Spare parts

ID	P-code	SN from	SN to	Mod.	Acces.	Volt	Description
Module:Exit shelf components [UX-110,BB 1100]							
33750	3020521		-	uw			End microswitch
33755	3020511		-	uw			Bracket door
33760	3003112		-	uw			Reed micro switch
33765	3009112		-	uw			Reed supprt
33770	3060136		-	uw			Bracket door pipe
33775	3060022		-	uw			Capstan / Pulley
33780	3060055		-	uw			Tape spacer
33785	3060032		-	uw			Inox key 8x6x20
33790	3020106		-	uw			Capstan / Shaft
33795	2001046		-	uw			Inox key 8x7x30
33800	560003		-	uw			Spring bracket door
33801	3020529		-	uw			Chain tightener support
33805	3020105		-	uw			Reduction motor gear 4/6P 400/415 V 50Hz
33810	3060180		-	uw			SITI reducing tree
33810	3060021		-	uw			BONFIGLIOLI reducing tree
33815	3060168		-	uw			Pinion Z10 1/2" - 5/16"
33820	3000210		-	uw			Right reduction 1:80 (DX)
33825	2001046		-	uw			Inox key 8x7x30
33830	3060041		-	uw			Chaine 1/2" 088
33835	3060003		-	uw			Pinion Z50 1/2" - 5/16"
33840	3060028		-	uw			Lateral support shaft
33845	3060194		-	uw			Viton seal ring 20.30.5 M.INOX
33850	3060129		-	uw			Cover with hole
33855	3060130		-	uw			Cover without hole
33860	13008		-	uw			Gasket OR-147 NBR
33865	3060199		-	uw			Spacer bearing
33870	3060167		-	uw			Chain tightener
33875	3060131		-	uw			Bearing 6004 42-20-12

e=ELECTRONICAL SWITCHES, uw=LOWER AND UPPER WASHER

85S=85S

dvgw=DVGW VALVE SYSTEM, bp=BOOSTER PUMP

A=3/N/PE~380-400V 50-60Hz, D=3/PE~200-210V 50-60Hz, F=2/PE~220-240V 50-60Hz, G=3/N/PE~415V 50-60Hz, H=3/PE~220-230V 50-60Hz, K=3/PE~380-400V 50-60Hz, L=3/PE~415V 50-60Hz, M=3/PE~440V 60Hz, P=1/N/PE~220-230V 50-60Hz, R=2/PE~220-240V 50-60Hz, U=1/N/PE~240V 50-60Hz, V=3/PE~240V 50-60Hz, W=1/N/PE~100-110V 50-60Hz

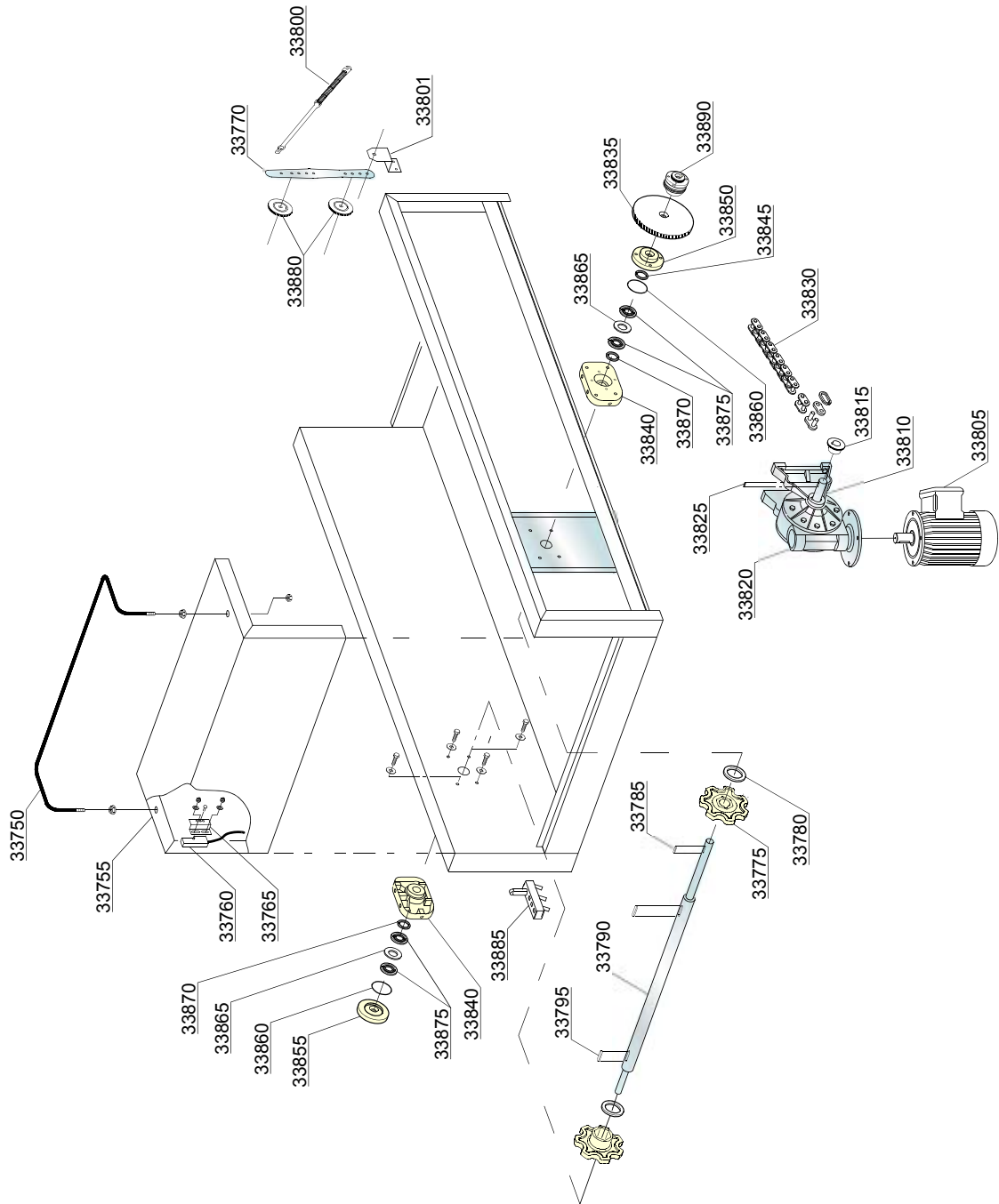

23_005xe

Spare parts

ID	P-code	SN from	SN to	Mod.	Acces.	Volt	Description
Module:Exit shelf components [UX-110,BB 1100]							
33880	3060042		-	uw			Chain tightener pinion
33885	70305		-	uw			End switch
33890	3020532		-	uw			Clutch kit

e=ELECTRONICAL SWITCHES, uw=LOWER AND UPPER WASHER

85S=85S

dvgw=DVGW VALVE SYSTEM, bp=BOOSTER PUMP

A=3/N/PE~380-400V 50-60Hz, D=3/PE~200-210V 50-60Hz, F=2/PE~220-240V 50-60Hz, G=3/N/PE~415V 50-60Hz, H=3/PE~220-230V 50-60Hz, K=3/PE~380-400V 50-60Hz, L=3/PE~415V 50-60Hz, M=3/PE~440V 60Hz, P=1/N/PE~220-230V 50-60Hz, R=2/PE~220-240V 50-60Hz, U=1/N/PE~240V 50-60Hz, V=3/PE~240V 50-60Hz, W=1/N/PE~100-110V 50-60Hz

26_002ye

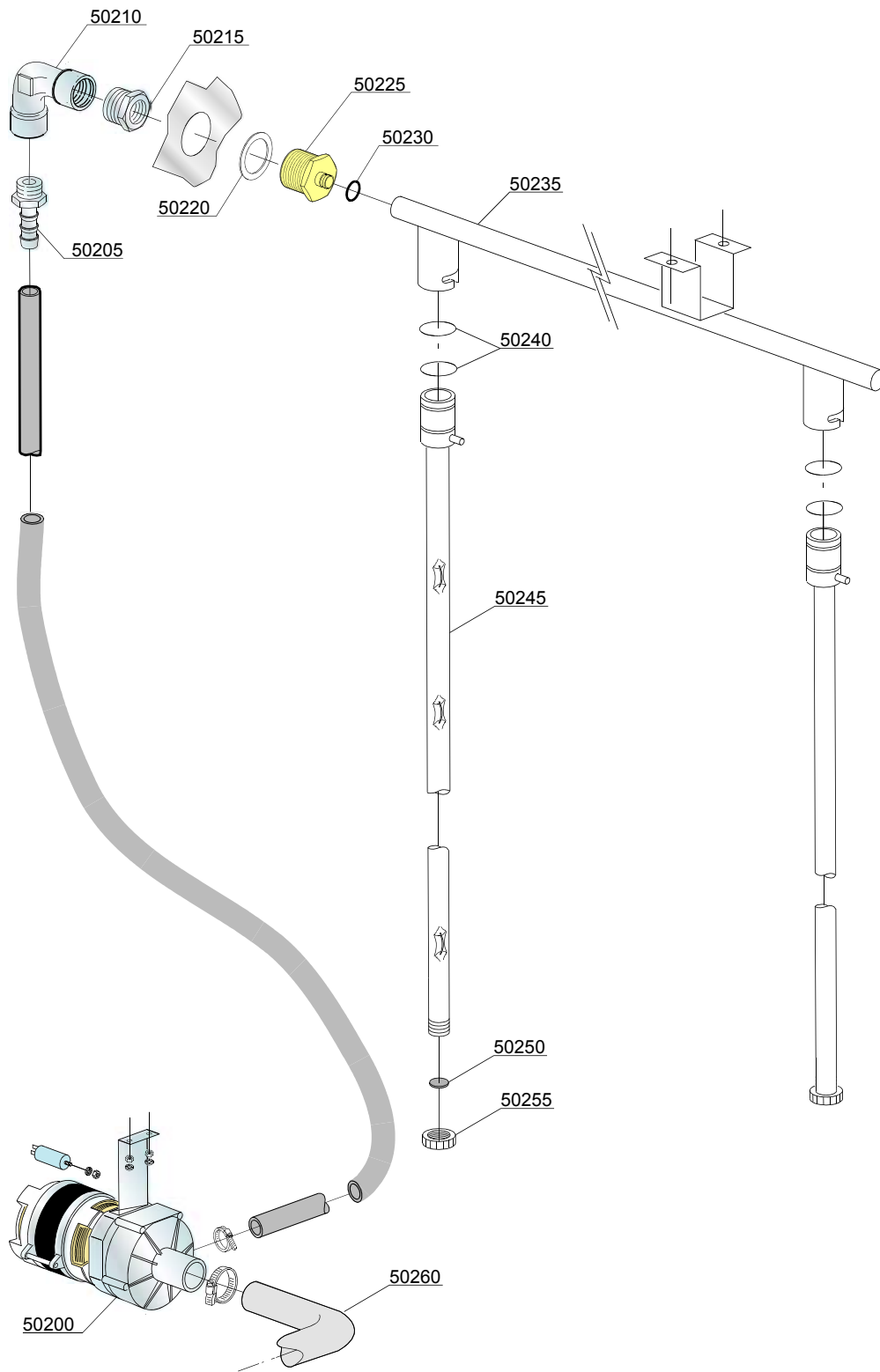

Spare parts

ID	P-code	SN from	SN to	Mod.	Acces.	Volt	Description
Module:Pre-rinsing system components [UX-110,BB 1100]							
50200	10501/C		-	e,uw			Pump 0,10 HP
50205	12023		-	e,uw			Rubber holder M 1/2 Ø12
50210	3003129		-	e,uw			3/8"G Rubber holder elbow
50215	12036		-	e,uw			Rdeuction nipples 1/2" - 3/8" F
50220	3009387		-	e,uw			12/10 Metal plain washer
50225	3003127		-	e,uw			Rinsing graft arm G 3/8 Ø 12
50230	391032		-	e,uw			OR gasket 108 NBR
50235	3020522		-	e,uw			Pre-rinsing ramp
50240	13000		-	e,uw			O-ring 3125
50245	3020523		-	e,uw			Pre-rinsing inox arm 3 nozzle
50250	2002051		-	e,uw			Gasket EPDM 17.5x1.5
50255	2002054		-	e,uw			Plug for arm
50260	3020533		-	e,uw			Elbow coupling press.

e=ELECTRONICAL SWITCHES, uw=LOWER AND UPPER WASHER

85S=85S

dvgw=DVGW VALVE SYSTEM, bp=BOOSTER PUMP

A=3/N/PE~380-400V 50-60Hz, D=3/PE~200-210V 50-60Hz, F=2/PE~220-240V 50-60Hz, G=3/N/PE~415V 50-60Hz, H=3/PE~220-230V 50-60Hz, K=3/PE~380-400V 50-60Hz, L=3/PE~415V 50-60Hz, M=3/PE~440V 60Hz, P=1/N/PE~220-230V 50-60Hz, R=2/PE~220-240V 50-60Hz, U=1/N/PE~240V 50-60Hz, V=3/PE~240V 50-60Hz, W=1/N/PE~100-110V 50-60Hz

26_002ze

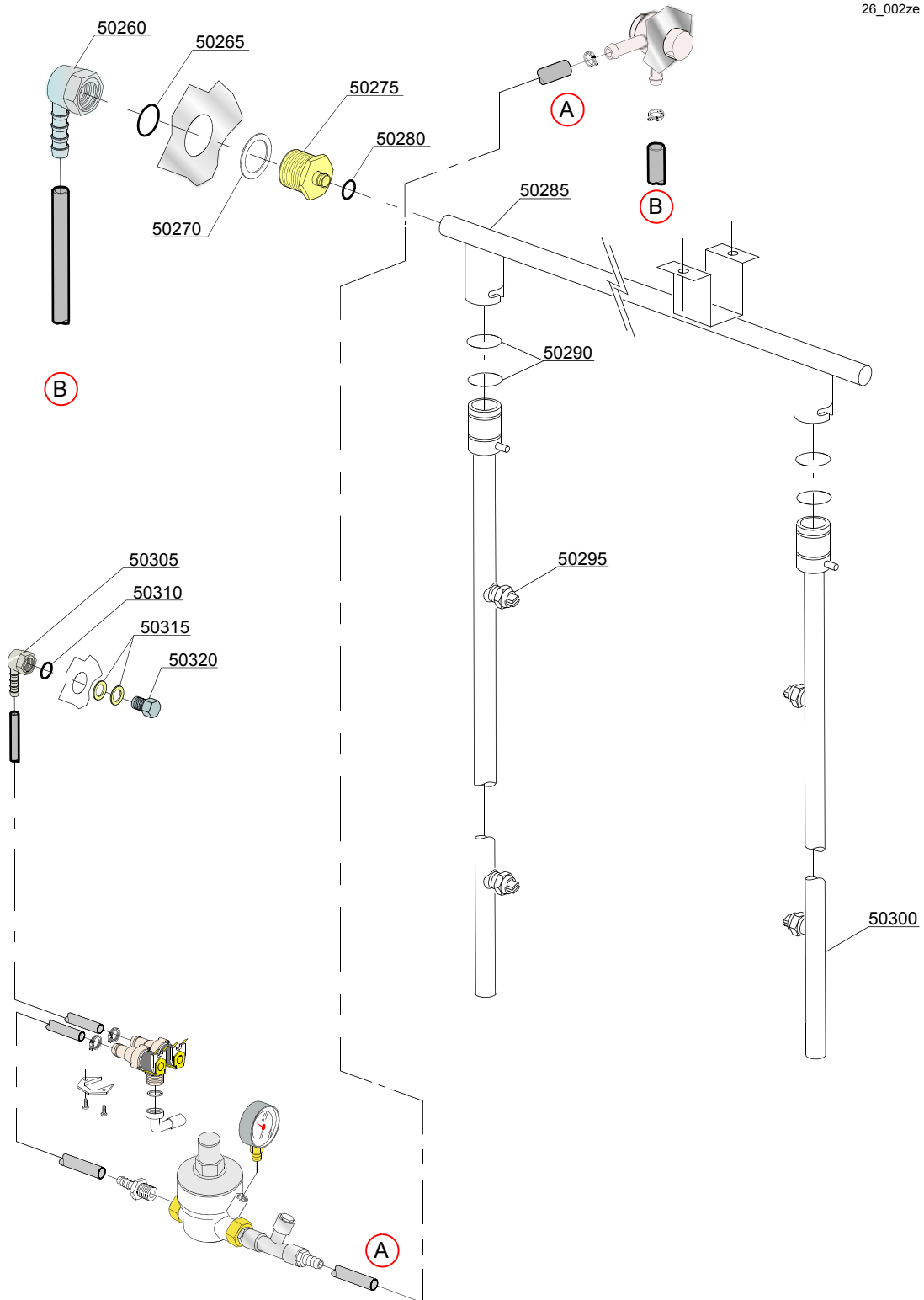

Spare parts

ID	P-code	SN from	SN to	Mod.	Acces.	Volt	Description
Module:Rinsing system components [UX-110,BB 1100]							
50260	3003129		-	e,uw			3/8"G Rubber holder elbow
50265	3003130		-	e,uw			OR gasket 123 NBR
50270	3009387		-	e,uw			12/10 Metal plain washer
50275	3003127		-	e,uw			Rinsing graft arm G 3/8 Ø 12
50280	13025		-	e,uw			O-ring Gasket 2081
50285	3020537		-	e,uw			Rinsing ramp
50290	13000		-	e,uw			OR gasket 108 NBR
50295	2200119		-	e,uw			Pre-rinsing ramp
50300	3020524		-	e,uw			O-ring 3125
50305	3003129		-	e,uw			3/8"G Rubber holder elbow
50310	3003130		-	e,uw			OR gasket 123 NBR
50315	10200171		-	e,uw			FASIT gasket 25x17x2
50320	3003128		-	e,uw			G 3/8" load water elbow

e=ELECTRONICAL SWITCHES, uw=LOWER AND UPPER WASHER

85S=85S

dvgw=DVGW VALVE SYSTEM, bp=BOOSTER PUMP

A=3/N/PE~380-400V 50-60Hz, D=3/PE~200-210V 50-60Hz, F=2/PE~220-240V 50-60Hz, G=3/N/PE~415V 50-60Hz, H=3/PE~220-230V 50-60Hz, K=3/PE~380-400V 50-60Hz, L=3/PE~415V 50-60Hz, M=3/PE~440V 60Hz, P=1/N/PE~220-230V 50-60Hz, R=2/PE~220-240V 50-60Hz, U=1/N/PE~240V 50-60Hz, V=3/PE~240V 50-60Hz, W=1/N/PE~100-110V 50-60Hz

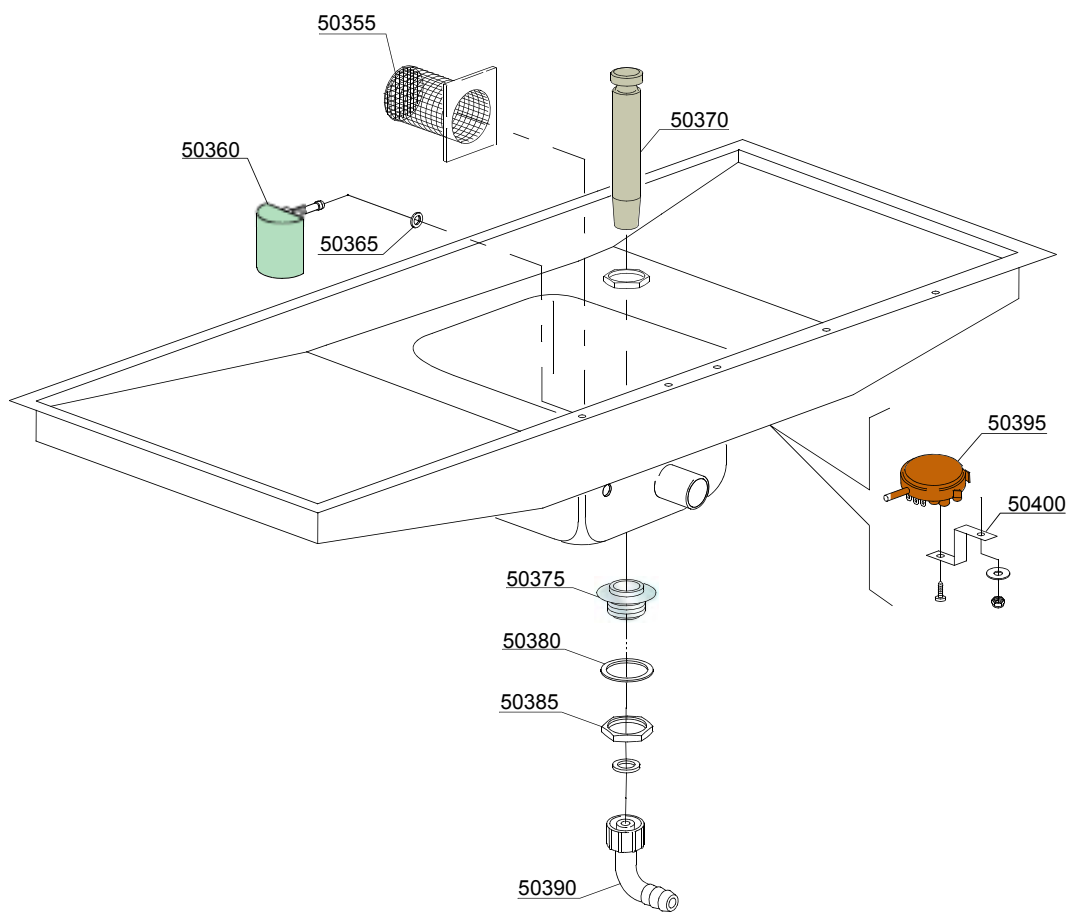
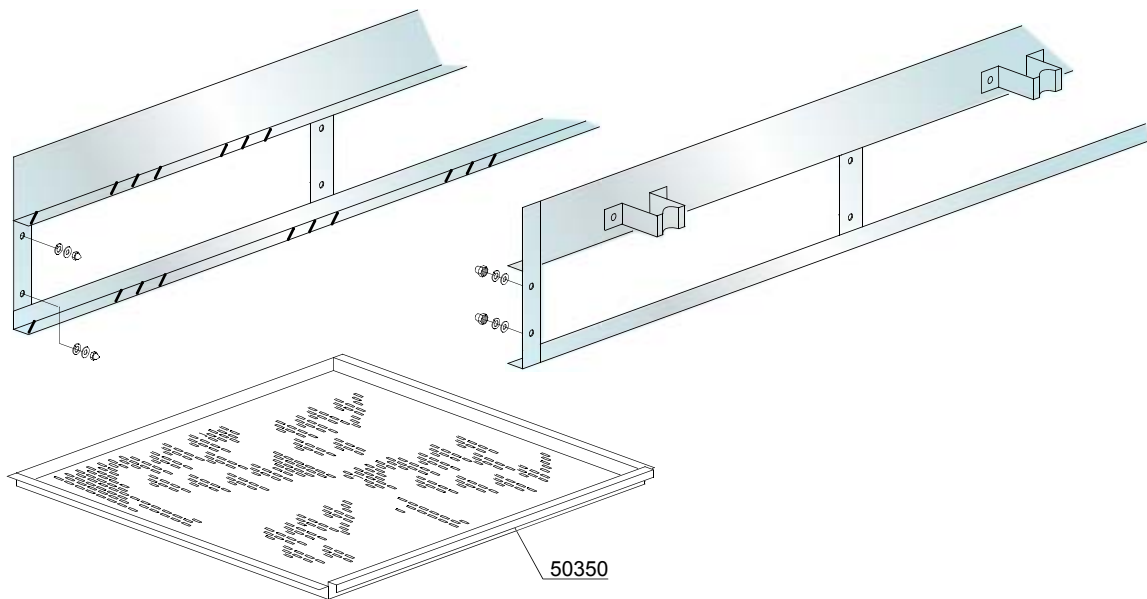

27_007xe

Spare parts

ID	P-code	SN from	SN to	Mod.	Acces.	Volt	Description
Module:Internal components [UX-110,BB 1100]							
50350	3020519		-	e,uw			Strainer plate
50355	10914		-	e,uw			Pump suction-filter
50360	135911		-	e,uw			Air trap
50365	13301		-	e,uw			Gasket ROLMART 14x8x1.5
50370	25004		-	e,uw			Overflow pipe assembly
50375	15063		-	e,uw			Stainless steel floor drain
50380	13305		-	e,uw			Gasket 44x32x3
50385	11701/A		-	e,uw			Nut
50390	15613		-	e,uw			1" 1/4x30 nylon elbow
50395	10706/A		-	e,uw			47-27 pressure switch
50400	3009363		-	e,uw			Pressure switch support

e=ELECTRONICAL SWITCHES, uw=LOWER AND UPPER WASHER

85S=85S

dvgw=DVGW VALVE SYSTEM, bp=BOOSTER PUMP

A=3/N/PE~380-400V 50-60Hz, D=3/PE~200-210V 50-60Hz, F=2/PE~220-240V 50-60Hz, G=3/N/PE~415V 50-60Hz, H=3/PE~220-230V 50-60Hz, K=3/PE~380-400V 50-60Hz, L=3/PE~415V 50-60Hz, M=3/PE~440V 60Hz, P=1/N/PE~220-230V 50-60Hz, R=2/PE~220-240V 50-60Hz, U=1/N/PE~240V 50-60Hz, V=3/PE~240V 50-60Hz, W=1/N/PE~100-110V 50-60Hz

30_005xe

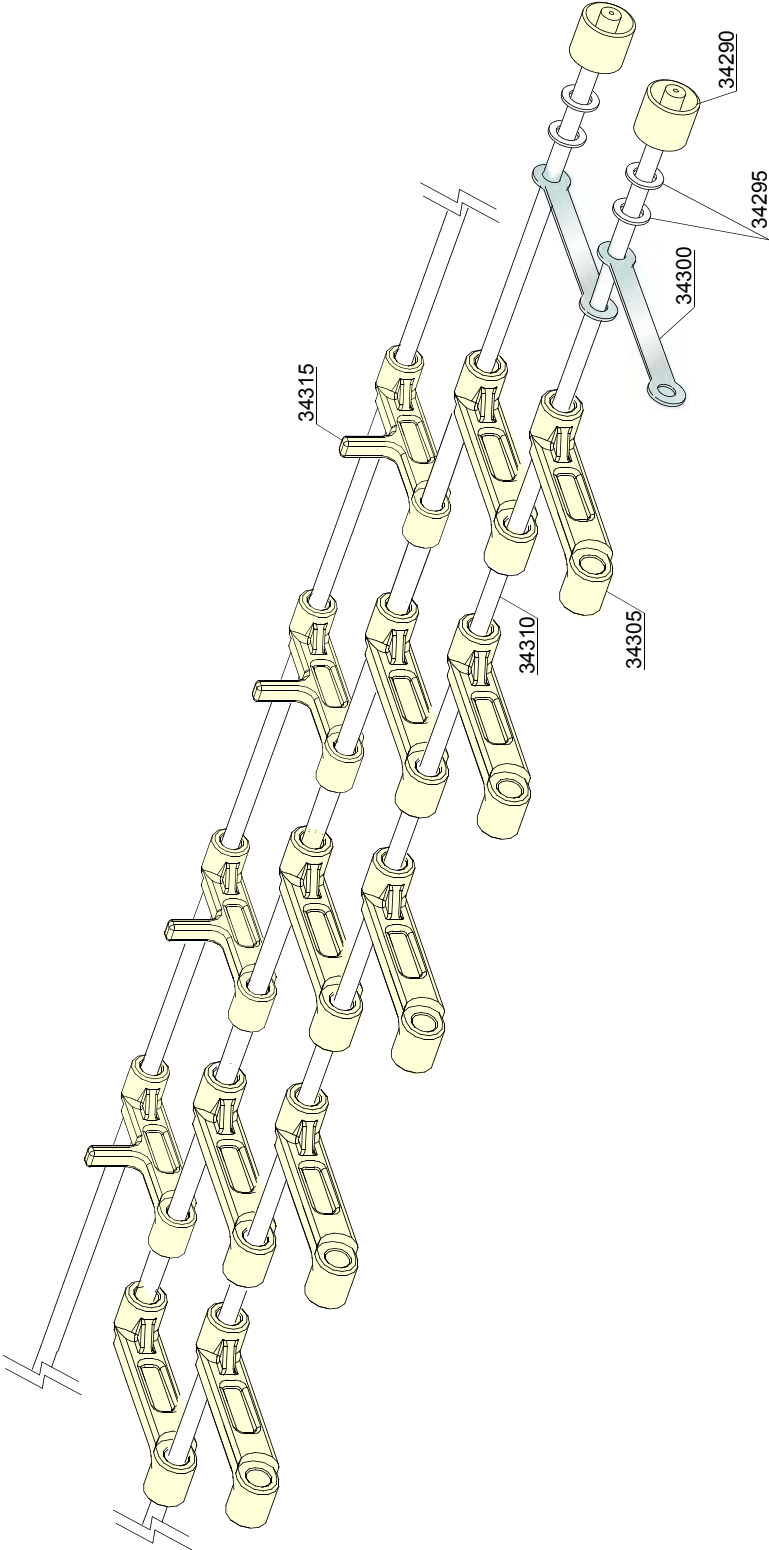

Spare parts

ID	P-code	SN from	SN to	Mod.	Acces.	Volt	Description
Module:Chain components [UX-110,BB 1100]							
34290	3020109		-	uw			Wheel
34295	11185		-	uw			Inox washer 8x16
34300	3060018		-	uw			Stainless steel link
34305	3060037		-	uw			Flat shaped finger for belt
34310	3020108		-	uw			Capstan shaft
34315	3060036		-	uw			Shaped finger for belt

e=ELECTRONICAL SWITCHES, uw=LOWER AND UPPER WASHER

85S=85S

dvgw=DVGW VALVE SYSTEM, bp=BOOSTER PUMP

A=3/N/PE~380-400V 50-60Hz, D=3/PE~200-210V 50-60Hz, F=2/PE~220-240V 50-60Hz, G=3/N/PE~415V 50-60Hz, H=3/PE~220-230V 50-60Hz, K=3/PE~380-400V 50-60Hz, L=3/PE~415V 50-60Hz, M=3/PE~440V 60Hz, P=1/N/PE~220-230V 50-60Hz, R=2/PE~220-240V 50-60Hz, U=1/N/PE~240V 50-60Hz, V=3/PE~240V 50-60Hz, W=1/N/PE~100-110V 50-60Hz

35_002xe

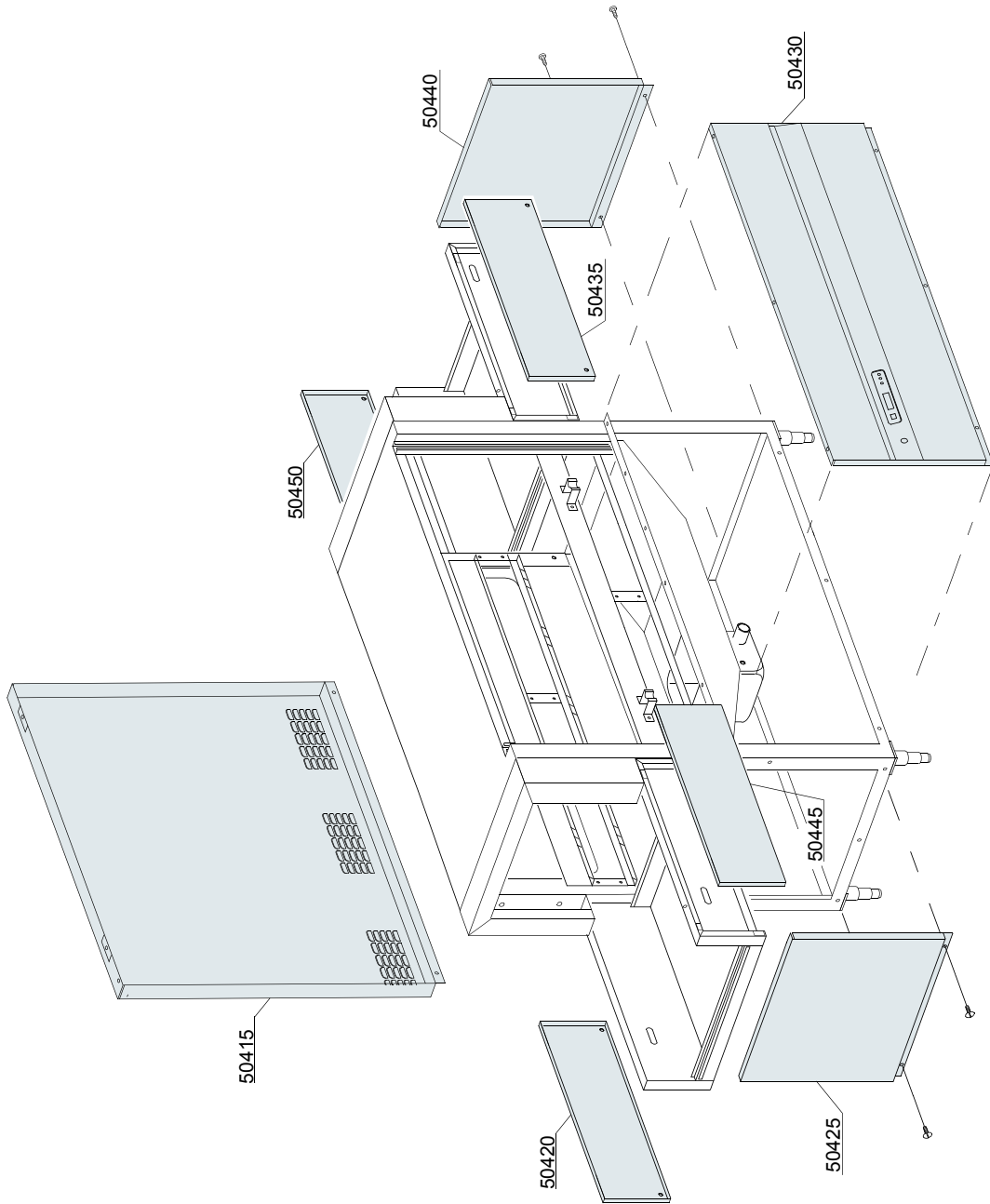

Spare parts

ID	P-code	SN from	SN to	Mod.	Acces.	Volt	Description
Module:Closing panels [UX-110,BB 1100]							
50415	3020515		-	uw			Back panel
50420	3020508		-	uw			Cover for large left side
50425	3020513		-	uw			Lateral panel left
50430	3020514		-	uw			Front lower door panel
50435	3020505		-	uw			Cover for tight right side
50440	3020512		-	uw			Lateral panel right
50445	3020506		-	uw			Cover for tight left side
50450	3020507		-	uw			Cover for wide right side

e=ELECTRONICAL SWITCHES, uw=LOWER AND UPPER WASHER

85S=85S

dvgw=DVGW VALVE SYSTEM, bp=BOOSTER PUMP

A=3/N/PE~380-400V 50-60Hz, D=3/PE~200-210V 50-60Hz, F=2/PE~220-240V 50-60Hz, G=3/N/PE~415V 50-60Hz, H=3/PE~220-230V 50-60Hz, K=3/PE~380-400V 50-60Hz, L=3/PE~415V 50-60Hz, M=3/PE~440V 60Hz, P=1/N/PE~220-230V 50-60Hz, R=2/PE~220-240V 50-60Hz, U=1/N/PE~240V 50-60Hz, V=3/PE~240V 50-60Hz, W=1/N/PE~100-110V 50-60Hz

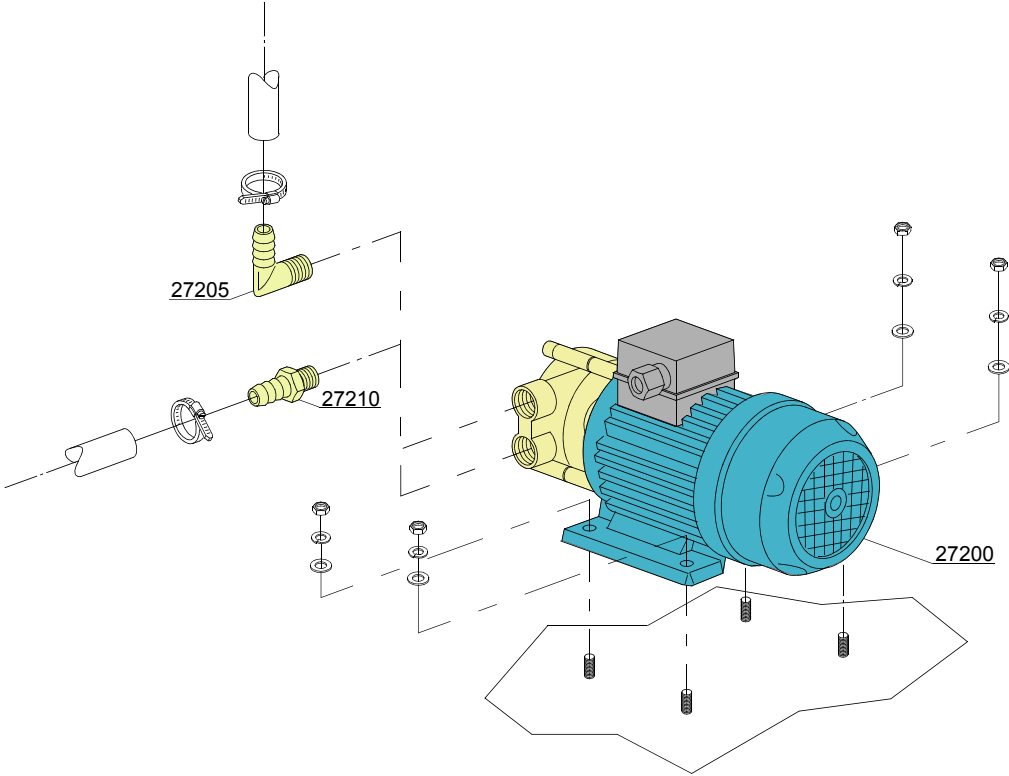
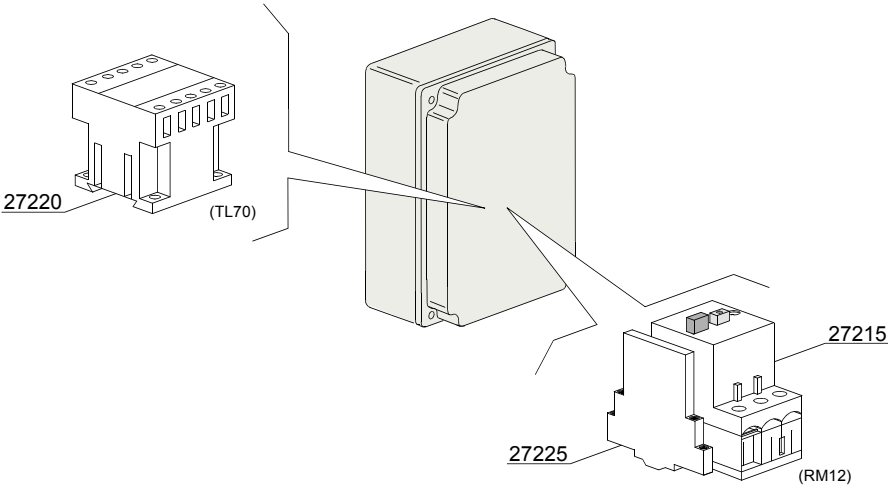

38_001xe

Spare parts

ID	P-code	SN from	SN to	Mod.	Acces.	Volt	Description
Module:Booster pump [UX-110,BB-1100]							
27200	15100		-		bp		Booster pump
27205	12030		-		bp		Elbow pipe fitting
27210	10221311		-		bp		Pipe fitting
27215	2000394		-		bp		Motorprotector 2,5-4A
27220	2000370		-		bp		Contactora MC9
27225	3006080		-		bp		Auxiliary contact LMS25

e=ELECTRONICAL SWITCHES, uw=LOWER AND UPPER WASHER

85S=85S

dvgw=DVGW VALVE SYSTEM, bp=BOOSTER PUMP

A=3/N/PE~380-400V 50-60Hz, D=3/PE~200-210V 50-60Hz, F=2/PE~220-240V 50-60Hz, G=3/N/PE~415V 50-60Hz, H=3/PE~220-230V 50-60Hz, K=3/PE~380-400V 50-60Hz, L=3/PE~415V 50-60Hz, M=3/PE~440V 60Hz, P=1/N/PE~220-230V 50-60Hz, R=2/PE~220-240V 50-60Hz, U=1/N/PE~240V 50-60Hz, V=3/PE~240V 50-60Hz, W=1/N/PE~100-110V 50-60Hz

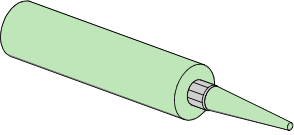
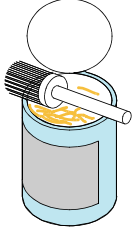
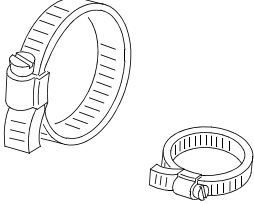
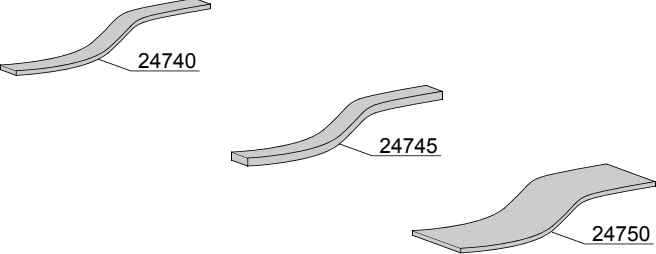
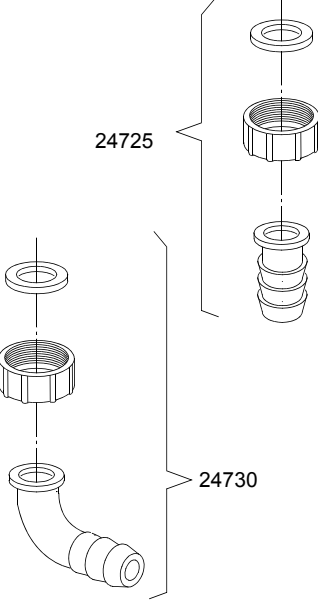
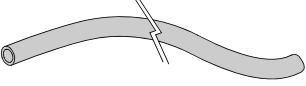
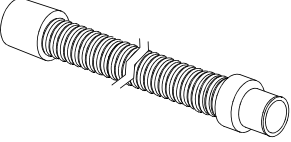
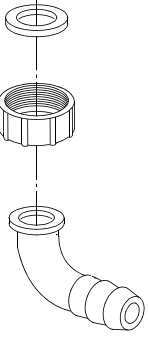
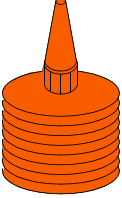
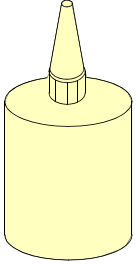
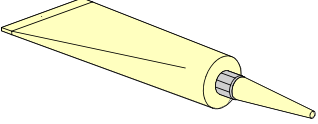
 <p>24700</p>	 <p>24705</p>	 <p>24760</p>
 <p>24740</p> <p>24745</p> <p>24750</p>		 <p>24725</p> <p>24730</p>
 <p>24755</p>	 <p>24735</p>	 <p>24730</p>
 <p>24765</p>	 <p>24770</p>	 <p>24775</p>

Spare parts

ID	P-code	SN from	SN to	Mod.	Acces.	Volt	Description
Module:Accessory [UX-110,BB 1100]							
24700	---		-				Silicone UNI 9610 - UNI 9611
24705	---		-				Grease for higt temperatures CCIAA 629224
24705	---		-				Grease for food - Loctite 8104 Cat. N° 26560
24725	15613/A		-				Fitting exauster
24730	15613		-				1" 1/4x30 nylon elbow
24735	10727		-				Exauster pipe Ø 24mm
24735	10200112		-				Exauster pipe Ø 32mm
24740	15750		-				20x2 self-stick mousse
24745	15751		-				20x4 self-stick mousse
24750	15752		-				60x2 self-stick mousse
24755	2907350		-				Flexible pipe EPDM Ø12
24755	2907352		-				Flexible pipe EPDM Ø12 - WRAS
24755	2907353		-				Flexible pipe EPDM Ø12
24760	11807		-				Steel hose clamp 15/24
24760	11806		-				Steel hose clamp 25/40
24760	11810		-				Steel hose clamp 40/60
24760	11824		-				Steel hose clamp 50/70
24760	2902491		-				Steel hose clamp 60/80
24765	---		-				-50°C +150°C threads dope
24770	---		-				Loctite 542 Cat.N° 54246 - DIN-DVGW 86.02 e 125
24770	---		-				Loctite 243 Cat.N° 18937 - 19386
24775	---		-				Loctite 511 Cat.N° 24003 - DIN-DVGW 86.01 e 125
24775	---		-				Loctite 577 Cat.N° 25392

e=ELECTRONICAL SWITCHES, uw=LOWER AND UPPER WASHER

85S=85S

dvgw=DVGW VALVE SYSTEM, bp=BOOSTER PUMP

A=3/N/PE~380-400V 50-60Hz, D=3/PE~200-210V 50-60Hz, F=2/PE~220-240V 50-60Hz, G=3/N/PE~415V 50-60Hz, H=3/PE~220-230V 50-60Hz, K=3/PE~380-400V 50-60Hz, L=3/PE~415V 50-60Hz, M=3/PE~440V 60Hz, P=1/N/PE~220-230V 50-60Hz, R=2/PE~220-240V 50-60Hz, U=1/N/PE~240V 50-60Hz, V=3/PE~240V 50-60Hz, W=1/N/PE~100-110V 50-60Hz