

# DISHWASHER

ELECTROMECHANICAL SWITCHES  
LOWER WASHING  
LOWER AND UPPER WASHING

TYPE: 102U

Accessories  
BOOSTER PUMP  
DVGW  
COLD RINSE  
WATER SOFTNER  
DETERGENT DISPENSER  
DRAIN PUMP

---

## Spare Parts Manual

---

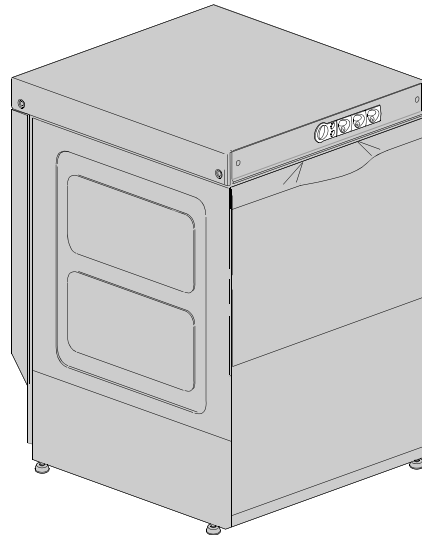

## INFORMAZIONI GENERALI

Questo catalogo serve per richiedere con esattezza le parti di ricambio

Nelle ordinazioni indicare:

1) il numero dei codici dei particolari seguito dalla descrizione e la quantità desiderata;

2) Il codice alfa-numerico presente nella seconda colonna della tabella ;

**I disegni delle parti di ricambio sono solo indicativi e non rappresentano il pezzo in oggetto.**

**I dati contenuti in questo catalogo sono indicativi e possono essere soggetti a modifiche senza impegno di preavviso.**

## ALLGEMEINE INFORMATIONEN

Dieser Ersatzteilkatalog dient zur genauen Angabe der Teile bei Ersatzteilbestellungen.

Bei Ersatzbestellung ist folgendes anzugeben:

1) Die Bestellnummer der Ersatzteile mit der entsprechenden Beschreibung genaue Menge;

2) Der alpha-numerischer Code auf der zweiten Reihe in dein Spalte;

**Die Zeichnungen der Ersatzteile sind nur als Hinweise gedacht und stellen nicht das betroffene Teil dar.**

**Bei den im Katalog angeführten Daten handelt es sich um Anhaltsdaten, die jederzeit, ohne Vorankündigung, geändert werden können.**

## GENERAL INFORMATION

The present spare parts order exactly the right spare parts

When ordering specify:

1) the part's code number followed by its description and quantity needed;

2) The alpha-numeric code is in the second column in the chart;

**Spare parts drawings are general and do not represent the part.**

**The contents of this catalogue are general and can undergo changes without prior notice.**

## INFORMACIONES GENERALES

El presente catálogo sirve para pedir con exactitud las partes de repuesto

En los pedidos se debe indicar:

1) el número de código de la parte y a continuación la descripción cantidad deseada;

2) El código alfanumerico presente en la signada columna de la tabla;

**Los diseños de las partes de recambio son solo indicativos y no representan la pieza en cuestión.**

**Los datos contenidos en el presente catálogo son indicativos y pueden modificarse sin aviso previo.**

## INFORMATIONS GENERALES

Ce catalogue permet de commander correctement les pièces détachées

Les commandes doivent être passées en indiquant:

1) le numero de code des pièces détachées suivi de leur description quantité désirée;

2) le code alphanumérique dans la deuxième colonne du tableau;

**Les plans des pièces détachées sont fournis seulement à titre indicatif et ne représentent pas la pièce concernée.**

**Les données de ce catalogue sont citées seulement à titre indicatif et peuvent être l'objet de modifications sans avis préalable.**

ESEMPIO  
EXAMPLE  
EXEMPLE  
BEISPIEL

Rif.	Codici
MODULE:Particolari	
10505	540903
10510	540908
10515	15065/A
10520	540086
10525	540028



## Note

Tutte le informazioni riportate si intendono aggiornate alla data di stampa. Il Produttore si riserva il diritto di apportare qualsiasi modifica richiesta dallo sviluppo evolutivo dei suddetti prodotti.

Per la sicurezza, la garanzia, l'affidabilità ed il valore della lavastoviglie usa solo ricambi originali. **Per alcuni codici, sono richieste quantità minime d'ordine.**



## Attenzione

Questo libretto è parte integrante della lavastoviglie e, in caso di passaggio di proprietà, deve essere consegnato al nuovo acquirente.



## Remarque

Toutes les informations contenues dans ce manuel s'entendent mises à jour à la date d'impression. En raison du développement constant de ses produits, usine se réserve le droit d'apporter à tout instant les modifications qu'elle jugera utiles.

Pour la sécurité, la garantie, la fiabilité et la valeur de votre lave-vaisselles n'utilisez que des pièces de rechange d'origine. **Pour quelque référence on demande un minimum de pièces par commande**



## Attention

Ce manuel doit être considéré comme partie intégrante de la lave-vaisselles, en cas de transfert de propriété, doit toujours être remis au nouveau propriétaire.



## Note

The information contained herein is valid at the time of going to print. The Company reserves the right to make any changes required by the future development of the above-mentioned products.

For your safety, as well as to preserve the warranty reliability and worth of your dishwashers, use original spare parts only. **For some codes a minimum quantity for order is required.**



## Warning

This manual forms an integral part of the dishwashers and - if a transfer of title occurs - must always be handed over to the new owner.



## Hinweis

Die Der Hersteller behält sich das Recht vor, jegliche, durch eine Weiterentwicklung der genannten Produkte bedingte Änderungen vornehmen zu können.

Verwenden Sie für Ihre Sicherheit, die Garantie, die Zuverlässigkeit und den Wert Ihrer machine originale Ersatzteile. **Für bestimmte Code nummer werden mindesten bestellungen verlangt.**



## Achtung

Diese Betriebsanleitung ist Bestandteil des machine und muss bei seinem Weiterverkauf dem neuen Besitzer ausgehändigt werden.



---

**Code** DW 999XXXXXX  
**Model DESCRIPTION**  
**S/N** DW A 1015770 Type .....

400V 3N 50HZ 8A  
3500W 500W



**IPX3** 16A

Pressione Dinamica alimentazione idrica 200-500 kPa  
 Pression dynamique arrivèe d'eau  
 Dynamic pressure water supply  
 Dynamischer Druck asserreinlauf

Pressione dinamica vapore saturo  
 Pression dynamique vapore satueèe  
 Dymanischer Druck gesattigter Dampf  
 Pression Dinamica Vapor Saturado

**CL/Part**

(N)

**TECHICAL SPECIFICATION**

MADE IN ITALY

Temperatura massima acqua in ingresso 60°C  
 Temperature max eau a l'entre  
 Maximale Temperatur Wasseranschlu  
 Maximum Water temperature in-feeding

---

Model 

S/N 

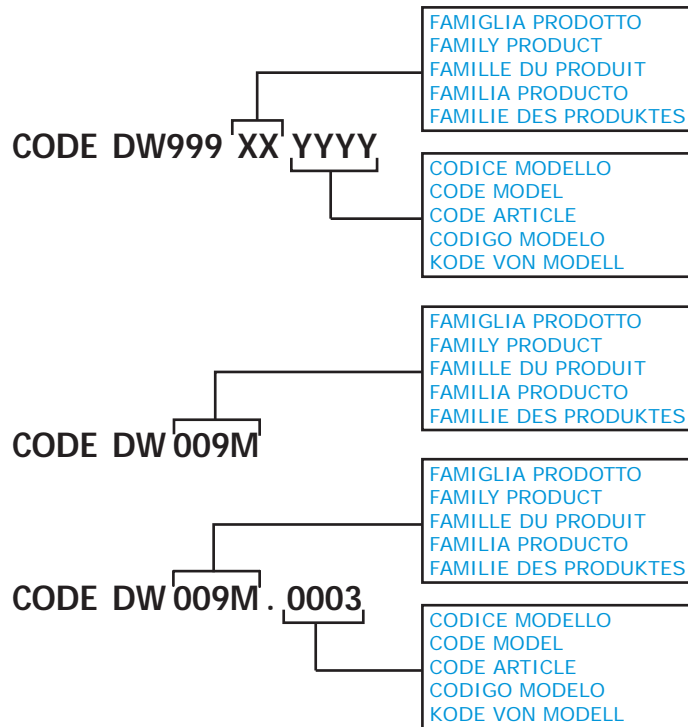



## 1. Spare parts

General body parts.....	9
Lockup system .....	11
Control panel and switches.....	13
Electric control components.....	15
Solenoid valve group .....	17
Solenoid valve group .....	19
Booster pump.....	21
DVGW valve .....	23
Water softner group.....	25
Rinse aid dispenser group.....	27
Boiler group .....	29
3 ways connection .....	31
4 ways connection .....	33
Wash pump .....	35
Dosing detergent group.....	37
Drain pump group.....	39

**Pressure switch group with air trap ...41**

**Turret group with rotating arms .....43**

**Turret group with rotating arms .....45**

## 1.1 Voltage codes

Volt	Voltage code
A	3/N/PE~380-400V 50-60Hz
D	3/PE~200-210V 50-60Hz
F	2/PE~220-240V 50-60Hz
G	3/N/PE~415V 50-60Hz
H	3/PE~220-230V 50-60Hz
K	3/PE~380-400V 50-60Hz
L	3/PE~415V 50-60Hz
M	3/PE~440V 60Hz
P	1/N/PE~220-230V 50-60Hz
R	2/PE~220-240V 50-60Hz
U	1/N/PE~240V 50-60Hz
V	3/PE~240V 50-60Hz
W	1/N/PE~100-110V 50-60Hz

## 1.2 Product codes

Product code	Full name
Model codes	
em	ELECTROMECHANICAL SWITCHES
lw	LOWER WASHING
uw	LOWER AND UPPER WASHING
Type codes	
102U	102U
Accessory codes	
bp	BOOSTER PUMP
dvgw	DVGW
cr	COLD RINSE
ws	WATER SOFTNER
dd	DETERGENT DISPENSER
dp	DRAIN PUMP

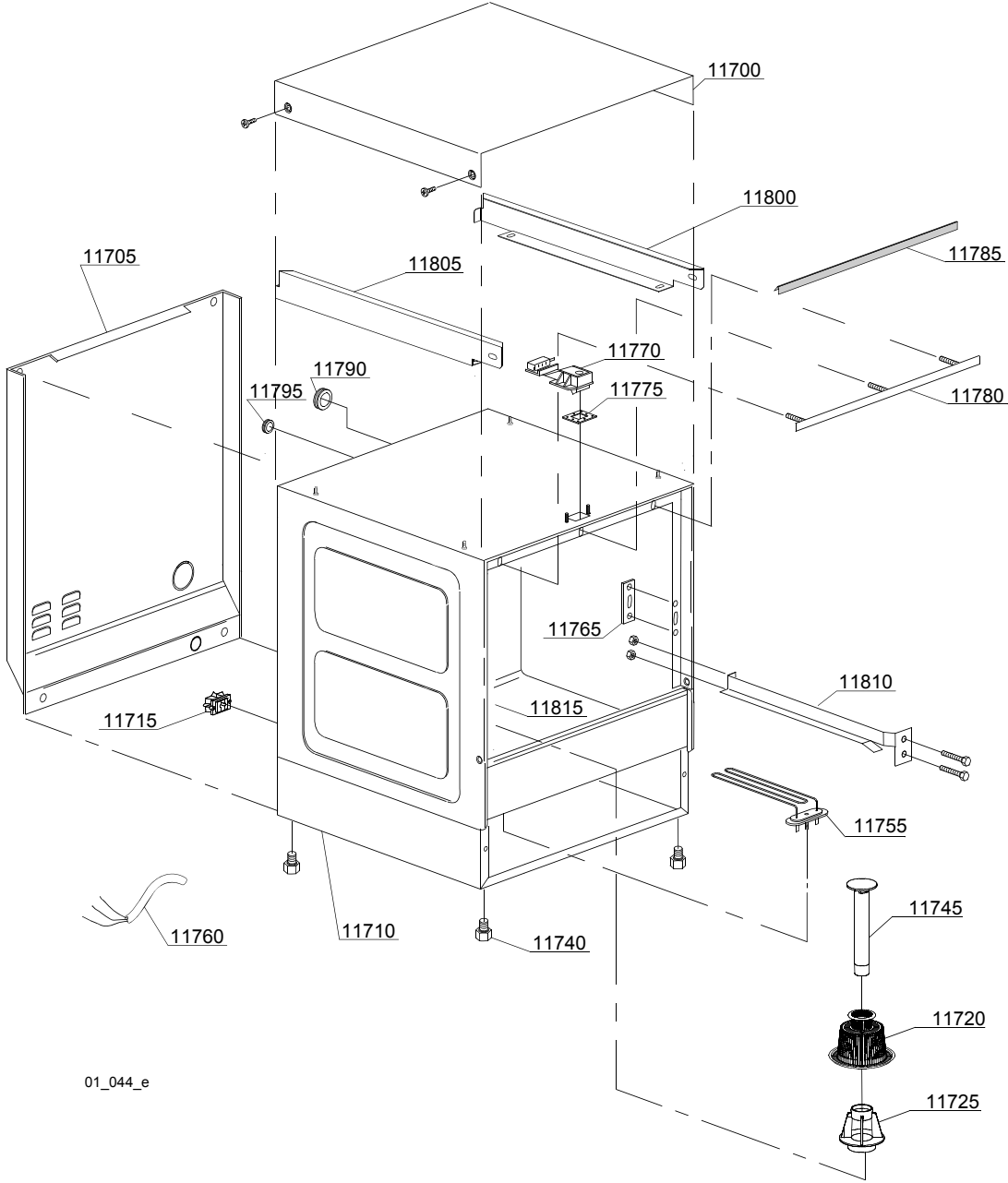



## Spare parts

ID	P-code	SN from	SN to	Mod.	Acces.	Volt	Description
<b>Module:General body parts</b>							
11700	270022		-				Cover
11705	270015		-				Back panel
11710	270600		-				Body
11710	270601		-		ws		Body
11715	15065/A		-				Cable-fastener with screw
11720	25003		-				Pump filter
11725	25002		-				Top filter body
11740	10850		-				M10x25 Ø40 black foot (minimum 4 pieces)
11745	25004		-				Overflow pipe
11755	16035/A		-				1,85/2,02 KW 230/240V 50Hz heating element
11755	16035/B		-				1,65 KW 110V 60Hz heating element
11760	10713		-				3x2,5x2500 cable
11765	150401		-				Door rod slide (minimum 4 pieces)
11770	150402		-				Door jack assembly
11775	150403		-				Door jack O-ring (minimum 5 pieces)
11780	270004		-				Door O-ring angular
11785	135205		-				Door O-ring
11790	13317		-				D.40mm unloading pipe pass (minimum 2 pieces)
11795	13323		-				D.13mm dosing pipe pass (minimum 2 pieces)
11800	270018		-				Left cover back support
11805	270019		-				Right cover back support
11810	270002		-				Right/left internal slide
11815	270003		-				Right/left internal slide

em=ELECTROMECHANICAL SWITCHES, lw=LOWER WASHING, uw=LOWER AND UPPER WASHING

102U=102U

bp=BOOSTER PUMP, dvgw=DVGW, cr=COLD RINSE, ws=WATER SOFTNER, dd=DETERGENT DISPENSER, dp=DRAIN PUMP

A=3/N/PE~380-400V 50-60Hz, D=3/PE~200-210V 50-60Hz, F=2/PE~220-240V 50-60Hz, G=3/N/PE~415V 50-60Hz, H=3/PE~220-230V 50-60Hz, K=3/PE~380-400V 50-60Hz, L=3/PE~415V 50-60Hz, M=3/PE~440V 60Hz, P=1/N/PE~220-230V 50-60Hz, R=2/PE~220-240V 50-60Hz, U=1/N/PE~240V 50-60Hz, V=3/PE~240V 50-60Hz, W=1/N/PE~100-110V 50-60Hz

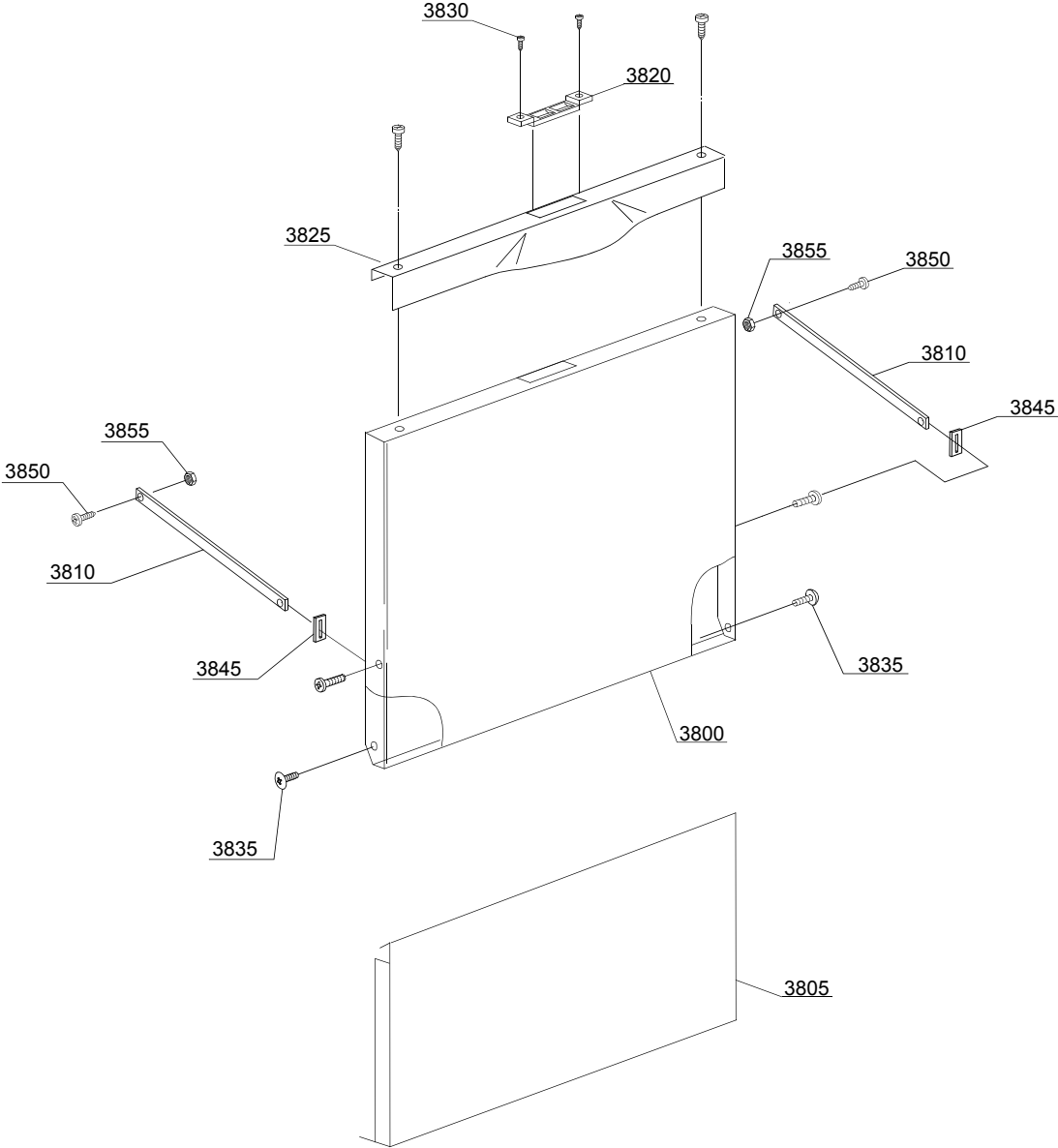

02\_103ue

## Spare parts

ID	P-code	SN from	SN to	Mod.	Acces.	Volt	Description
<b>Module: Lockup system</b>							
3800	270005		-				Door
3805	270016		-				Lower door
3810	250041		-				Right/left door rod
3820	150402/D		-				Door jack
3825	270010		-				Stainless steel handle
3830	11139		-				Stainless steel screw
3835	11219		-				M5x25 stainless steel screw
3845	250042		-				Hinge door rod
3850	11121		-				M4x8 screw (minimum 20 pieces)
3855	11703		-				M4 inox Plated nut

em=ELECTROMECHANICAL SWITCHES, lw=LOWER WASHING, uw=LOWER AND UPPER WASHING

102U=102U

bp=BOOSTER PUMP, dvgw=DVGW, cr=COLD RINSE, ws=WATER SOFTNER, dd=DETERGENT DISPENSER, dp=DRAIN PUMP

A=3/N/PE~380-400V 50-60Hz, D=3/PE~200-210V 50-60Hz, F=2/PE~220-240V 50-60Hz, G=3/N/PE~415V 50-60Hz, H=3/PE~220-230V 50-60Hz, K=3/PE~380-400V 50-60Hz, L=3/PE~415V 50-60Hz, M=3/PE~440V 60Hz, P=1/N/PE~220-230V 50-60Hz, R=2/PE~220-240V 50-60Hz, U=1/N/PE~240V 50-60Hz, V=3/PE~240V 50-60Hz, W=1/N/PE~100-110V 50-60Hz

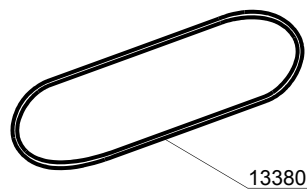
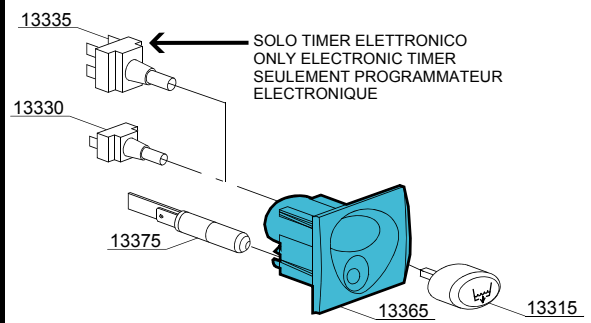
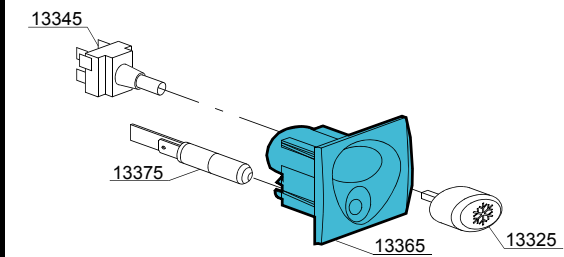
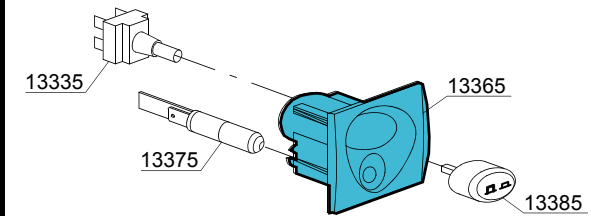
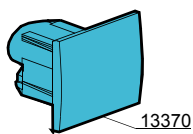
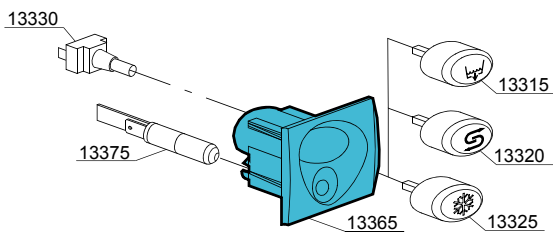
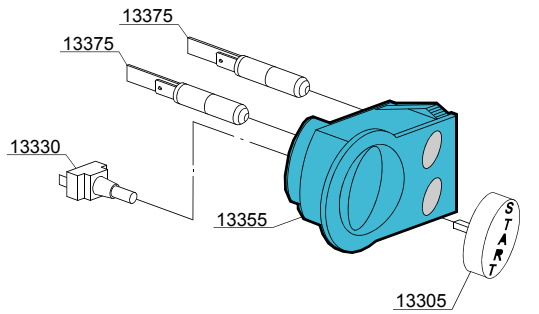
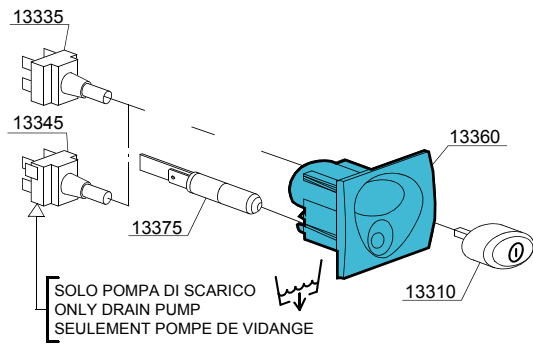
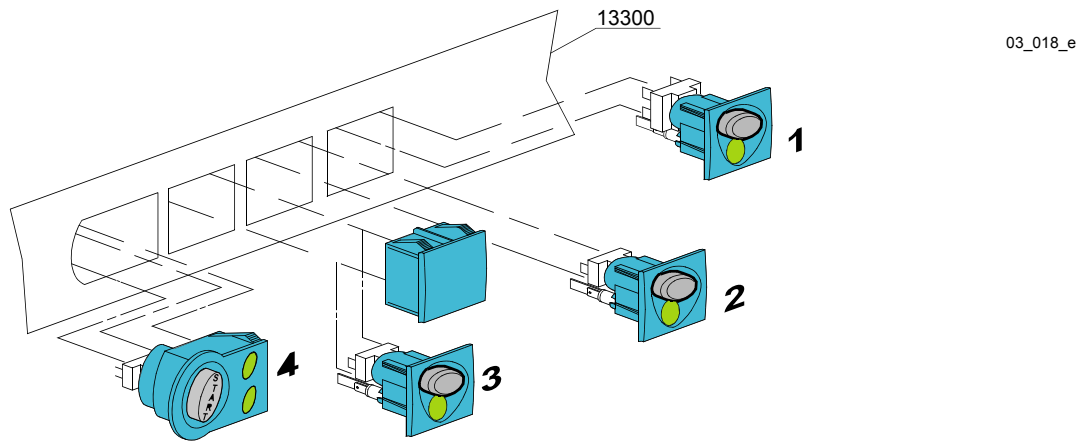

## Spare parts

ID	P-code	SN from	SN to	Mod.	Acces.	Volt	Description
<b>Module:Control panel and switches</b>							
13300	270025		-	em			Control panel
13305	89347		-	em			Start push button
13310	89340		-	em			ON-OFF push button
13315	89343		-	em	dp		Drain pump push button
13320	89345		-	em	ws		Regeneration push button
13325	89344		-	em	cr		Hot/cold push button
13330	15813		-	em			16A unipolar switch
13335	15812		-	em			16A switch
13335	15800		-	em			16A bipolar switch
13345	15811		-	em			16A bipolar switch
13345	15811/A		-	em			16A bipolar switch
13355	89301		-	em			Start push button support
13360	89304		-	em			Push button support
13365	89302		-	em	dp,ws,cr		Push button support
13370	89303		-	em			Closed support
13375	15826		-	em			Pilot light 220V
13380	89333		-	em			OR O-ring (minimum 3 pieces)

em=ELECTROMECHANICAL SWITCHES, lw=LOWER WASHING, uw=LOWER AND UPPER WASHING

102U=102U

bp=BOOSTER PUMP, dvgw=DVGW, cr=COLD RINSE, ws=WATER SOFTNER, dd=DETERGENT DISPENSER, dp=DRAIN PUMP

A=3/N/PE~380-400V 50-60Hz, D=3/PE~200-210V 50-60Hz, F=2/PE~220-240V 50-60Hz, G=3/N/PE~415V 50-60Hz, H=3/PE~220-230V 50-60Hz, K=3/PE~380-400V 50-60Hz, L=3/PE~415V 50-60Hz, M=3/PE~440V 60Hz, P=1/N/PE~220-230V 50-60Hz, R=2/PE~220-240V 50-60Hz, U=1/N/PE~240V 50-60Hz, V=3/PE~240V 50-60Hz, W=1/N/PE~100-110V 50-60Hz

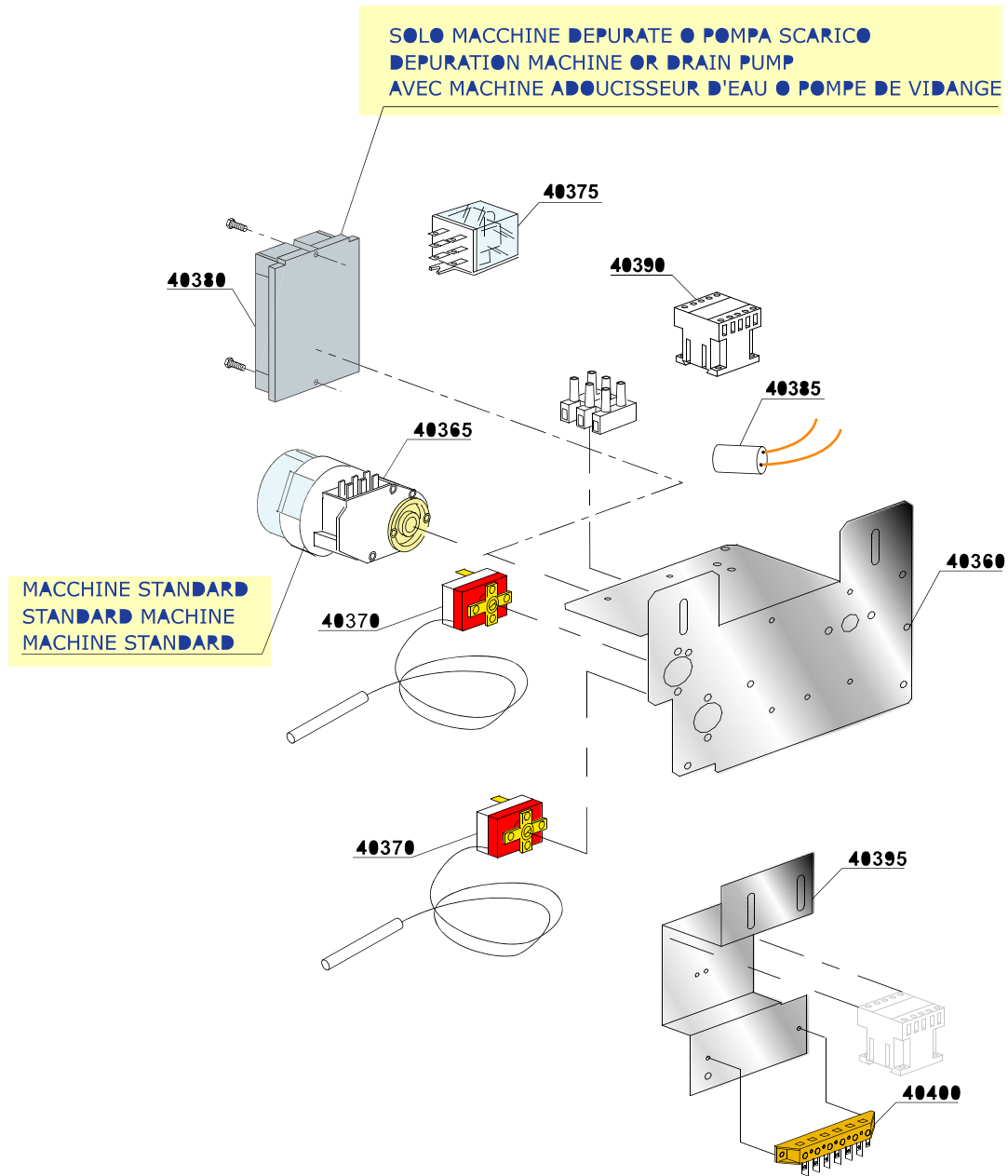

04\_043\_e

## Spare parts

ID	P-code	SN from	SN to	Mod.	Acces.	Volt	Description
<b>Module:Electric control components</b>							
40360	25020		-	em,uw			Electric component panel
40365	10708/T		-	em,uw	ws		Timer 120" with thermostop - 230Vac 50Hz
40365	10708/E		-	em,uw	ws		Timer 120" with thermostop - 110Vac 60Hz
40370	10707/1		-	em,uw			0-90°C thermostat
40375	16047		-	em,uw			Tripolar relay 16A - 230Vac 50/60 Hz
40375	560303		-	em,uw			Finder relay 16A - 110V
40375	15620		-	em,uw	dp		16A bipolar relay in deviation
40380	50553		-	em,uw	ws,dp		3 times electronic timer with regeneration
40385	15146		-	em,uw			Low noise filter F3
40390	15158		-	em,uw			Contactora 110V
40395	401019		-	em,uw			Contactora support for extra power
40400	500551		-	em,uw			6 poles terminal board

em=ELECTROMECHANICAL SWITCHES, lw=LOWER WASHING, uw=LOWER AND UPPER WASHING

102U=102U

bp=BOOSTER PUMP, dvgw=DVGW, cr=COLD RINSE, ws=WATER SOFTNER, dd=DETERGENT DISPENSER, dp=DRAIN PUMP

A=3/N/PE~380-400V 50-60Hz, D=3/PE~200-210V 50-60Hz, F=2/PE~220-240V 50-60Hz, G=3/N/PE~415V 50-60Hz, H=3/PE~220-230V 50-60Hz, K=3/PE~380-400V 50-60Hz, L=3/PE~415V 50-60Hz, M=3/PE~440V 60Hz, P=1/N/PE~220-230V 50-60Hz, R=2/PE~220-240V 50-60Hz, U=1/N/PE~240V 50-60Hz, V=3/PE~240V 50-60Hz, W=1/N/PE~100-110V 50-60Hz

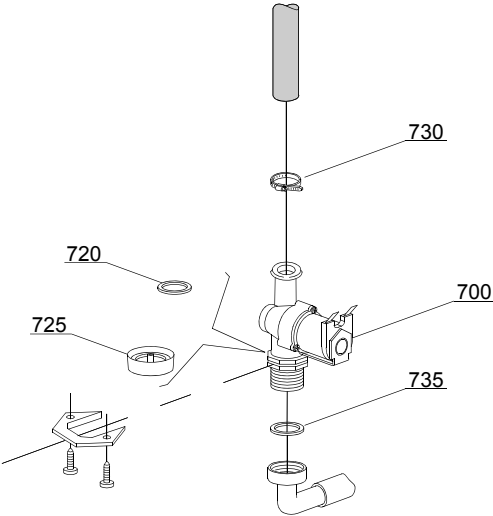

05\_002\_e



## Spare parts

ID	P-code	SN from	SN to	Mod.	Acces.	Volt	Description
<b>Module:Solenoid valve group</b>							
700	10703		-	em			Single solenoid valve - 230Vac
700	10703/A		-	em			Single solenoid valve - 110Vac
720	N.C.		-	em			Pression reducing valve
725	15315		-	em			Red pression reducing valve support (minimum 2 pieces)
730	11807		-	em			12/22 clamp (minimum 3 pieces)
735	13307		-	em			3/4 gasket

em=ELECTROMECHANICAL SWITCHES, lw=LOWER WASHING, uw=LOWER AND UPPER WASHING

102U=102U

bp=BOOSTER PUMP, dvgw=DVGW, cr=COLD RINSE, ws=WATER SOFTNER, dd=DETERGENT DISPENSER, dp=DRAIN PUMP

A=3/N/PE~380-400V 50-60Hz, D=3/PE~200-210V 50-60Hz, F=2/PE~220-240V 50-60Hz, G=3/N/PE~415V 50-60Hz, H=3/PE~220-230V 50-60Hz, K=3/PE~380-400V 50-60Hz, L=3/PE~415V 50-60Hz, M=3/PE~440V 60Hz, P=1/N/PE~220-230V 50-60Hz, R=2/PE~220-240V 50-60Hz, U=1/N/PE~240V 50-60Hz, V=3/PE~240V 50-60Hz, W=1/N/PE~100-110V 50-60Hz

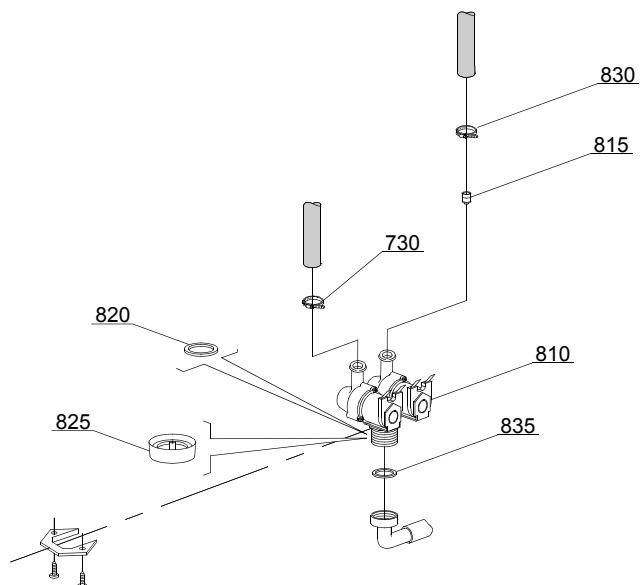

05\_003\_€

## Spare parts

ID	P-code	SN from	SN to	Mod.	Acces.	Volt	Description
<b>Module:Solenoid valve group</b>							
810	15098		-	em	cr,ws		Double solenoid valve - Ø10 - 230Vac
810	15098/A		-	em	cr		Double solenoid valve - 110Vac
815	15115		-	em	cr,ws		Green pression solenoid valve for regeneration (minimum 2 pieces)
820	N.C.		-	em	cr,ws		Pression reducing valve
825	15315		-	em	cr,ws		Red pression reducing valve support (minimum 2 pieces)
825	15315/A		-	em			Brown pression reducing valve support
830	11807		-	em			12/22 clamp (minimum 3 pieces)
835	13307		-	em			3/4 gasket

em=ELECTROMECHANICAL SWITCHES, lw=LOWER WASHING, uw=LOWER AND UPPER WASHING  
102U=102U

bp=BOOSTER PUMP, dvgw=DVGW, cr=COLD RINSE, ws=WATER SOFTNER, dd=DETERGENT DISPENSER,  
dp=DRAIN PUMP

A=3/N/PE~380-400V 50-60Hz, D=3/PE~200-210V 50-60Hz, F=2/PE~220-240V 50-60Hz, G=3/N/PE~415V 50-60Hz,  
H=3/PE~220-230V 50-60Hz, K=3/PE~380-400V 50-60Hz, L=3/PE~415V 50-60Hz, M=3/PE~440V 60Hz, P=1/N/PE~220-  
230V 50-60Hz, R=2/PE~220-240V 50-60Hz, U=1/N/PE~240V 50-60Hz, V=3/PE~240V 50-60Hz, W=1/N/PE~100-110V  
50-60Hz

07\_003pe

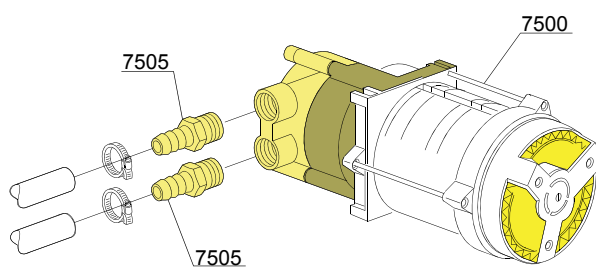

VERSIONE STANDARD / VERSIONE POMPA AUM. PRESSIONE  
STANDARD VERSION / BOOSTER PUMP VERSION  
VERSION STANDARD / VERSION POMPE AUGMENT. PRESSION

## Spare parts

ID	P-code	SN from	SN to	Mod.	Acces.	Volt	Description
<b>Module:Booster pump</b>							
7500	15100/D		-	em	bp		Booster pump 220/240V - body pumps in brass
7505	10221311		-	em	bp		Rubber holder Ø 12 3/8G

em=ELECTROMECHANICAL SWITCHES, lw=LOWER WASHING, uw=LOWER AND UPPER WASHING

102U=102U

bp=BOOSTER PUMP, dvgw=DVGW, cr=COLD RINSE, ws=WATER SOFTNER, dd=DETERGENT DISPENSER, dp=DRAIN PUMP

A=3/N/PE~380-400V 50-60Hz, D=3/PE~200-210V 50-60Hz, F=2/PE~220-240V 50-60Hz, G=3/N/PE~415V 50-60Hz, H=3/PE~220-230V 50-60Hz, K=3/PE~380-400V 50-60Hz, L=3/PE~415V 50-60Hz, M=3/PE~440V 60Hz, P=1/N/PE~220-230V 50-60Hz, R=2/PE~220-240V 50-60Hz, U=1/N/PE~240V 50-60Hz, V=3/PE~240V 50-60Hz, W=1/N/PE~100-110V 50-60Hz

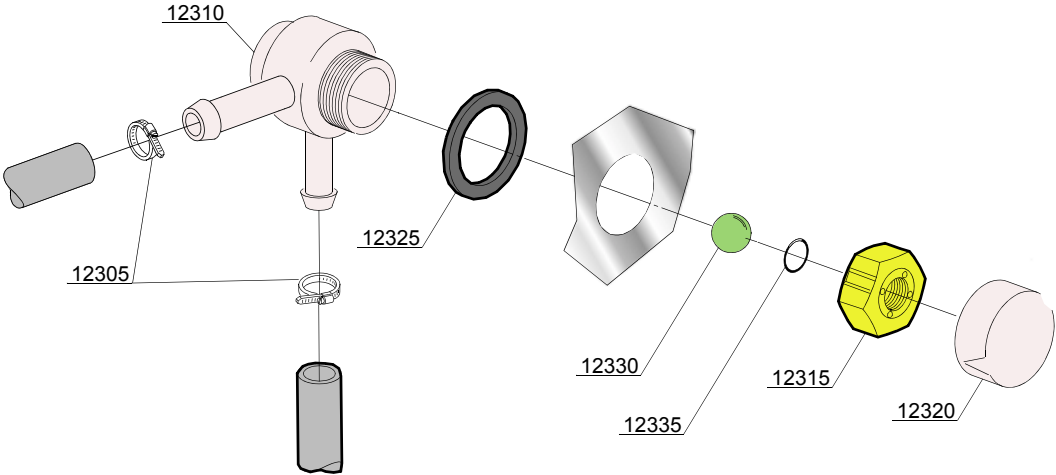

08\_005xe

## Spare parts

ID	P-code	SN from	SN to	Mod.	Acces.	Volt	Description
<b>Module:DVGW valve</b>							
12305	11807		-		dvgw		Clamp aisi430 12/22
12310	15286		-		dvgw		Valve body center
12315	15281		-		dvgw		Flat valve
12320	15282		-		dvgw		Flat valve cover
12325	15283		-		dvgw		Valve gasket
12330	15284		-		dvgw		Sphere
12335	15285		-		dvgw		O-ring 115 KTW

em=ELECTROMECHANICAL SWITCHES, lw=LOWER WASHING, uw=LOWER AND UPPER WASHING

102U=102U

bp=BOOSTER PUMP, dvgw=DVGW, cr=COLD RINSE, ws=WATER SOFTNER, dd=DETERGENT DISPENSER, dp=DRAIN PUMP

A=3/N/PE~380-400V 50-60Hz, D=3/PE~200-210V 50-60Hz, F=2/PE~220-240V 50-60Hz, G=3/N/PE~415V 50-60Hz, H=3/PE~220-230V 50-60Hz, K=3/PE~380-400V 50-60Hz, L=3/PE~415V 50-60Hz, M=3/PE~440V 60Hz, P=1/N/PE~220-230V 50-60Hz, R=2/PE~220-240V 50-60Hz, U=1/N/PE~240V 50-60Hz, V=3/PE~240V 50-60Hz, W=1/N/PE~100-110V 50-60Hz

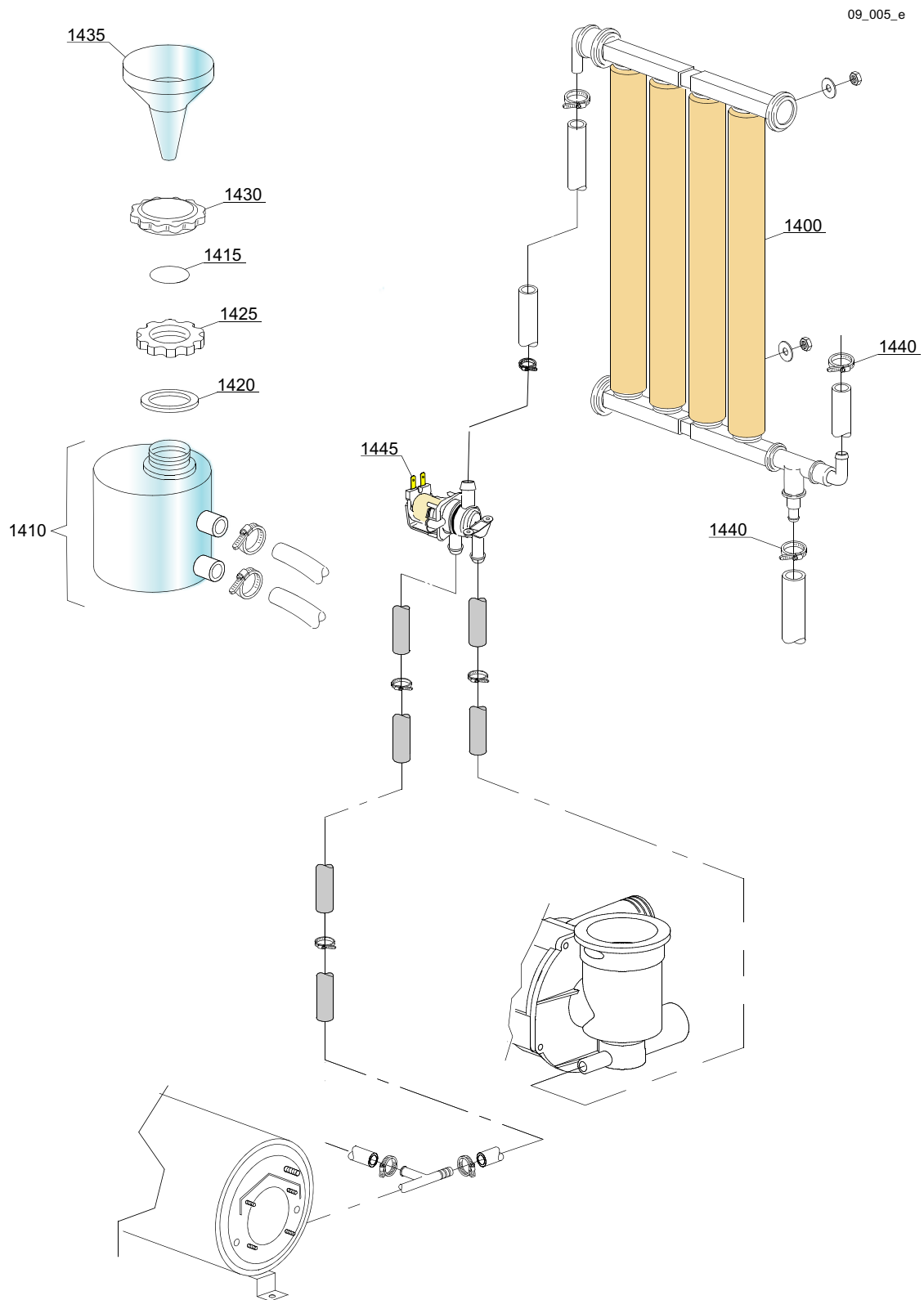



## Spare parts

ID	P-code	SN from	SN to	Mod.	Acces.	Volt	Description
<b>Module: Water softner group</b>							
1400	16066		-	em	ws		4 elements water softner
1410	16065		-	em	ws		Salt container
1415	16067/A		-	em	ws		OR O-ring
1420	16067/B		-	em	ws		O-ring
1425	16067/C		-	em	ws		Ring nut
1430	16067/D		-	em	ws		Plug
1435	16082		-	em	ws		Funnel
1440	11807		-	em	ws		12/22 clamp (minimum 3 pieces)
1445	15213		-	em	ws		Single solenoid valve

em=ELECTROMECHANICAL SWITCHES, lw=LOWER WASHING, uw=LOWER AND UPPER WASHING

102U=102U

bp=BOOSTER PUMP, dvgw=DVGW, cr=COLD RINSE, ws=WATER SOFTNER, dd=DETERGENT DISPENSER, dp=DRAIN PUMP

A=3/N/PE~380-400V 50-60Hz, D=3/PE~200-210V 50-60Hz, F=2/PE~220-240V 50-60Hz, G=3/N/PE~415V 50-60Hz, H=3/PE~220-230V 50-60Hz, K=3/PE~380-400V 50-60Hz, L=3/PE~415V 50-60Hz, M=3/PE~440V 60Hz, P=1/N/PE~220-230V 50-60Hz, R=2/PE~220-240V 50-60Hz, U=1/N/PE~240V 50-60Hz, V=3/PE~240V 50-60Hz, W=1/N/PE~100-110V 50-60Hz

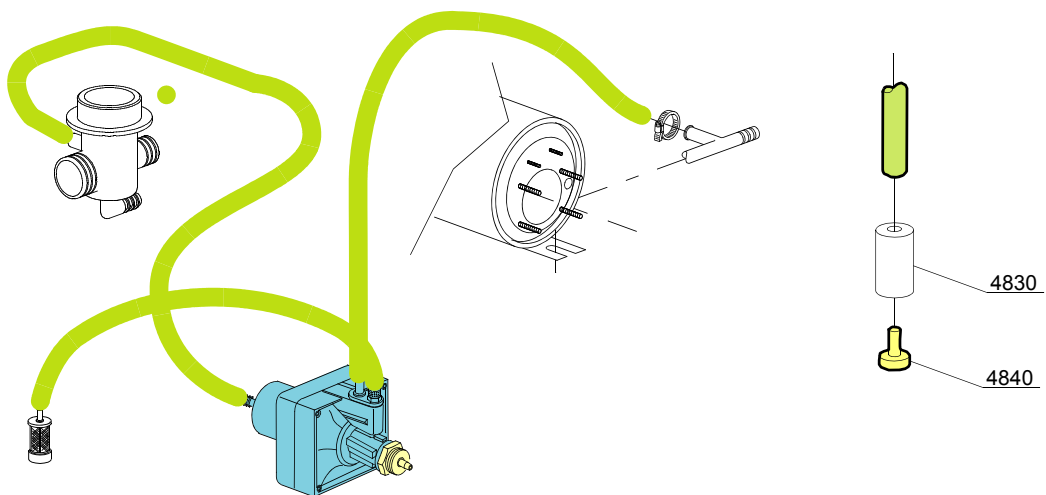
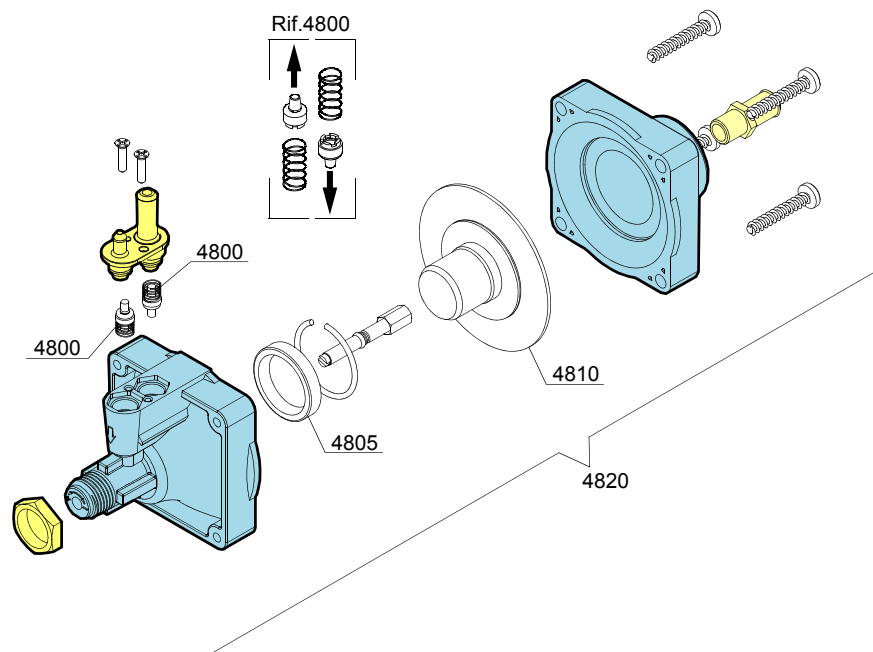

10\_006\_e

## Spare parts

ID	P-code	SN from	SN to	Mod.	Acces.	Volt	Description
<b>Module: Rinse aid dispenser group</b>							
4800	10805		-	em			Tecnopro non return valve
4805	10806		-	em			Ø22 O-ring
4810	10807		-	em			Membrane
4820	10799		-	em			TECNO PRO rinse aid dispenser
4830	12525		-	em			Ballast
4840	15058		-	em			Small filter (minimum 3 pieces)

em=ELECTROMECHANICAL SWITCHES, lw=LOWER WASHING, uw=LOWER AND UPPER WASHING

102U=102U

bp=BOOSTER PUMP, dvgw=DVGW, cr=COLD RINSE, ws=WATER SOFTNER, dd=DETERGENT DISPENSER, dp=DRAIN PUMP

A=3/N/PE~380-400V 50-60Hz, D=3/PE~200-210V 50-60Hz, F=2/PE~220-240V 50-60Hz, G=3/N/PE~415V 50-60Hz, H=3/PE~220-230V 50-60Hz, K=3/PE~380-400V 50-60Hz, L=3/PE~415V 50-60Hz, M=3/PE~440V 60Hz, P=1/N/PE~220-230V 50-60Hz, R=2/PE~220-240V 50-60Hz, U=1/N/PE~240V 50-60Hz, V=3/PE~240V 50-60Hz, W=1/N/PE~100-110V 50-60Hz

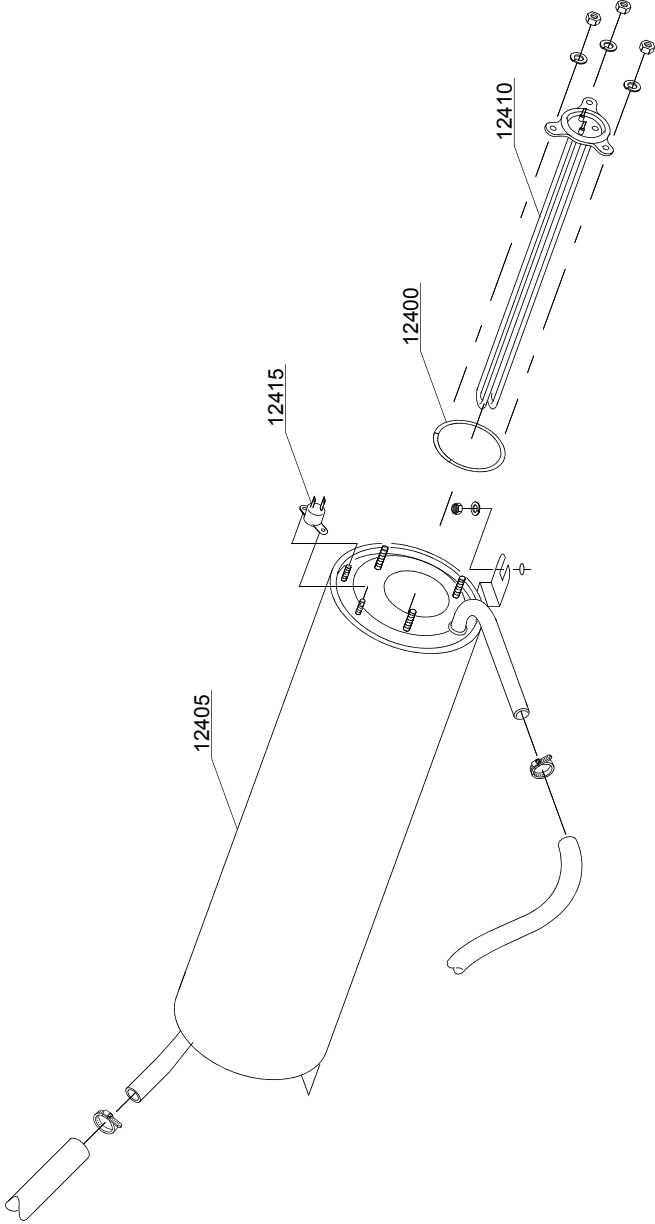

11\_007pe

## Spare parts

ID	P-code	SN from	SN to	Mod.	Acces.	Volt	Description
<b>Module:Boiler group</b>							
12400	13010		-	em			OR O-ring (minimum 5 pieces)
12405	140905		-	em			Boiler
12410	18206/B		-	em			2,4/2,61KW 110V heating element
12410	18206		-	em			2,4/2,61KW 230/240V heating element
12410	18206/D		-	em			2,8/3,05KW 230/240V heating element
12410	16035/A		-	em			1,85/2,61KW 230/240V heating element
12415	15550		-	em			Safety thermostat

em=ELECTROMECHANICAL SWITCHES, lw=LOWER WASHING, uw=LOWER AND UPPER WASHING

102U=102U

bp=BOOSTER PUMP, dvgw=DVGW, cr=COLD RINSE, ws=WATER SOFTNER, dd=DETERGENT DISPENSER, dp=DRAIN PUMP

A=3/N/PE~380-400V 50-60Hz, D=3/PE~200-210V 50-60Hz, F=2/PE~220-240V 50-60Hz, G=3/N/PE~415V 50-60Hz, H=3/PE~220-230V 50-60Hz, K=3/PE~380-400V 50-60Hz, L=3/PE~415V 50-60Hz, M=3/PE~440V 60Hz, P=1/N/PE~220-230V 50-60Hz, R=2/PE~220-240V 50-60Hz, U=1/N/PE~240V 50-60Hz, V=3/PE~240V 50-60Hz, W=1/N/PE~100-110V 50-60Hz

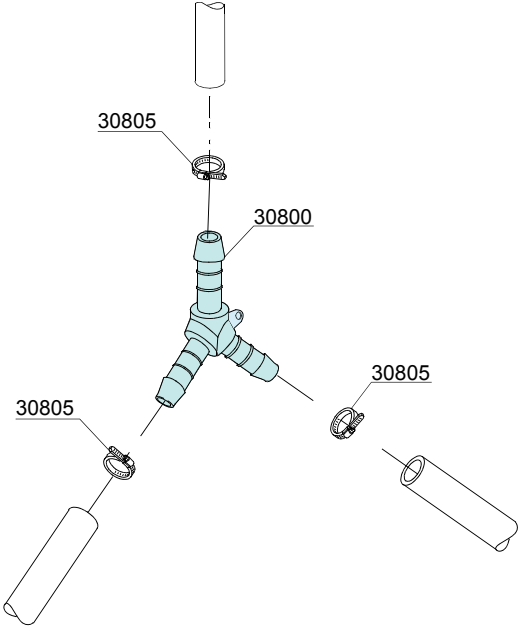

12\_003pe

## Spare parts

ID	P-code	SN from	SN to	Mod.	Acces.	Volt	Description
<b>Module:3 ways connection</b>							
30800	540090		-	em			Ø10 mm plastic 3 ways connection
30805	11807		-	em			12/22 clamp (minimum 3 pieces)

em=ELECTROMECHANICAL SWITCHES, lw=LOWER WASHING, uw=LOWER AND UPPER WASHING

102U=102U

bp=BOOSTER PUMP, dvgw=DVGW, cr=COLD RINSE, ws=WATER SOFTNER, dd=DETERGENT DISPENSER, dp=DRAIN PUMP

A=3/N/PE~380-400V 50-60Hz, D=3/PE~200-210V 50-60Hz, F=2/PE~220-240V 50-60Hz, G=3/N/PE~415V 50-60Hz, H=3/PE~220-230V 50-60Hz, K=3/PE~380-400V 50-60Hz, L=3/PE~415V 50-60Hz, M=3/PE~440V 60Hz, P=1/N/PE~220-230V 50-60Hz, R=2/PE~220-240V 50-60Hz, U=1/N/PE~240V 50-60Hz, V=3/PE~240V 50-60Hz, W=1/N/PE~100-110V 50-60Hz

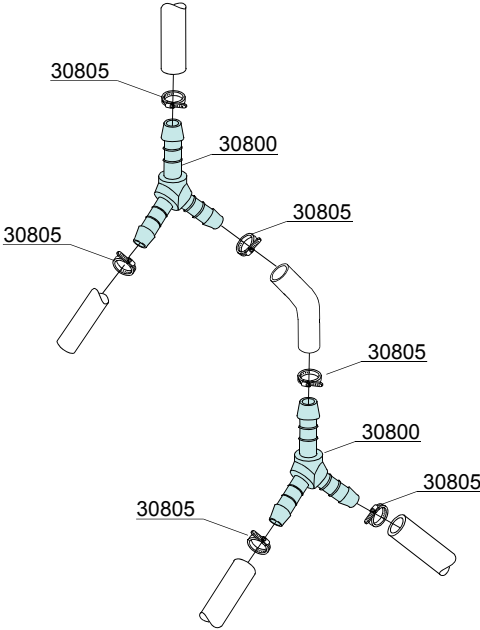

12\_010pe



## Spare parts

ID	P-code	SN from	SN to	Mod.	Acces.	Volt	Description
<b>Module:4 ways connection</b>							
30800	540090		-	em	cr		Ø10 mm plastic 3 ways connection
30805	11807		-	em	cr		12/22 clamp (minimum 3 pieces)

em=ELECTROMECHANICAL SWITCHES, lw=LOWER WASHING, uw=LOWER AND UPPER WASHING

102U=102U

bp=BOOSTER PUMP, dvgw=DVGW, cr=COLD RINSE, ws=WATER SOFTNER, dd=DETERGENT DISPENSER, dp=DRAIN PUMP

A=3/N/PE~380-400V 50-60Hz, D=3/PE~200-210V 50-60Hz, F=2/PE~220-240V 50-60Hz, G=3/N/PE~415V 50-60Hz, H=3/PE~220-230V 50-60Hz, K=3/PE~380-400V 50-60Hz, L=3/PE~415V 50-60Hz, M=3/PE~440V 60Hz, P=1/N/PE~220-230V 50-60Hz, R=2/PE~220-240V 50-60Hz, U=1/N/PE~240V 50-60Hz, V=3/PE~240V 50-60Hz, W=1/N/PE~100-110V 50-60Hz

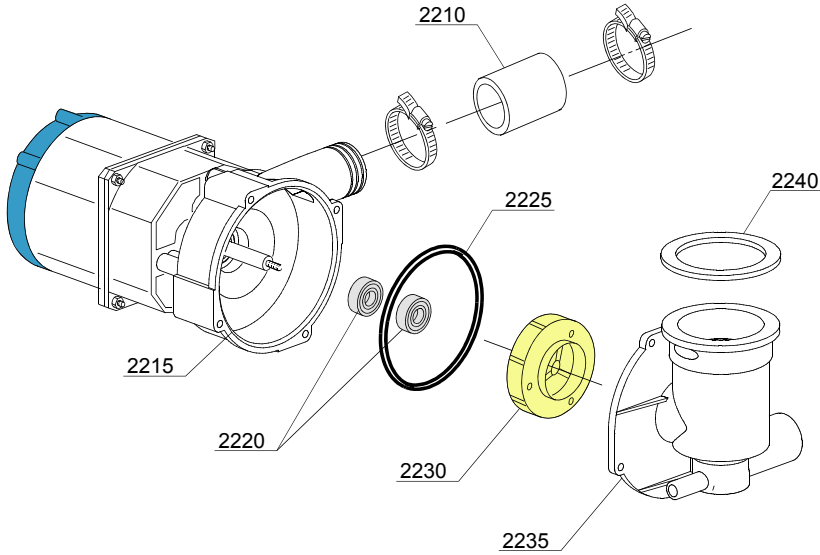
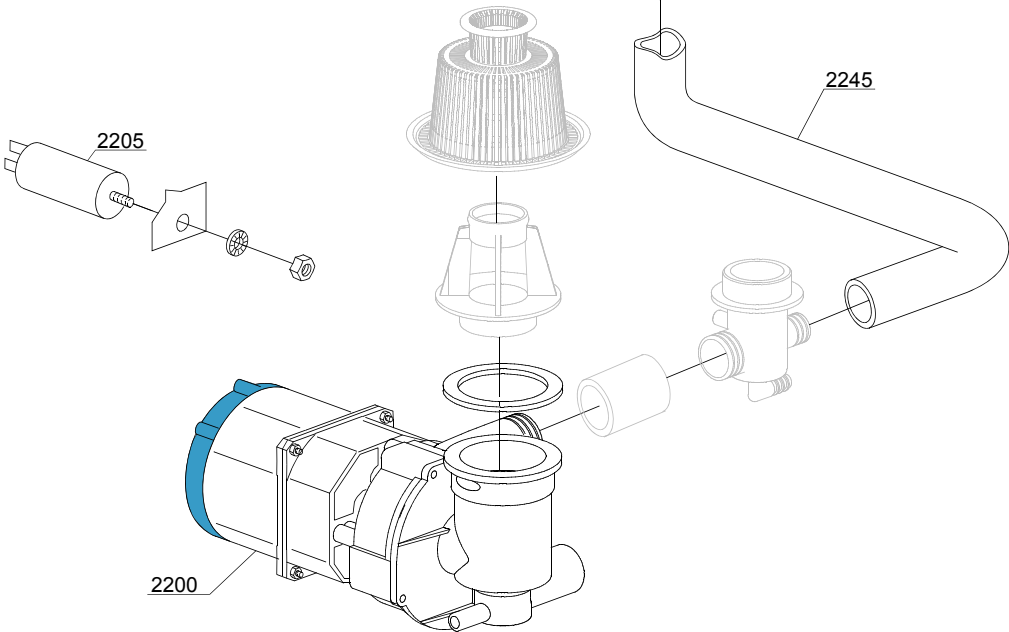

13\_132\_e

## Spare parts

ID	P-code	SN from	SN to	Mod.	Acces.	Volt	Description
<b>Module: Wash pump</b>							
2200	25024		-	lw			250W wash pump - 230V 50Hz
2200	25025		-	lw			250W wash pump - 220V 60Hz
2200	25026		-	lw			250W wash pump - 110V 60Hz
2205	10702		-	lw			5 uF condenser - 450V
2210	25019		-	lw			Pump-turret pipe coupling
2215	25000		-	lw			Back Flange RL/09
2220	15080		-	lw			Pump shaft O-rings
2225	25029		-	lw			85x1,5 RL/09 OR O-ring
2230	25024/A		-	lw			Pump rotor (50Hz)
2230	25024/B		-	lw			Pump rotor (60Hz)
2235	25001		-	lw			Front flange RL/09
2240	25009		-	lw			Water trap gasket
2245	25018		-	lw			Connecting pipe to the upper washing arms

em=ELECTROMECHANICAL SWITCHES, lw=LOWER WASHING, uw=LOWER AND UPPER WASHING  
102U=102U

bp=BOOSTER PUMP, dvgw=DVGW, cr=COLD RINSE, ws=WATER SOFTNER, dd=DETERGENT DISPENSER,  
dp=DRAIN PUMP

A=3/N/PE~380-400V 50-60Hz, D=3/PE~200-210V 50-60Hz, F=2/PE~220-240V 50-60Hz, G=3/N/PE~415V 50-60Hz,  
H=3/PE~220-230V 50-60Hz, K=3/PE~380-400V 50-60Hz, L=3/PE~415V 50-60Hz, M=3/PE~440V 60Hz, P=1/N/PE~220-  
230V 50-60Hz, R=2/PE~220-240V 50-60Hz, U=1/N/PE~240V 50-60Hz, V=3/PE~240V 50-60Hz, W=1/N/PE~100-110V  
50-60Hz

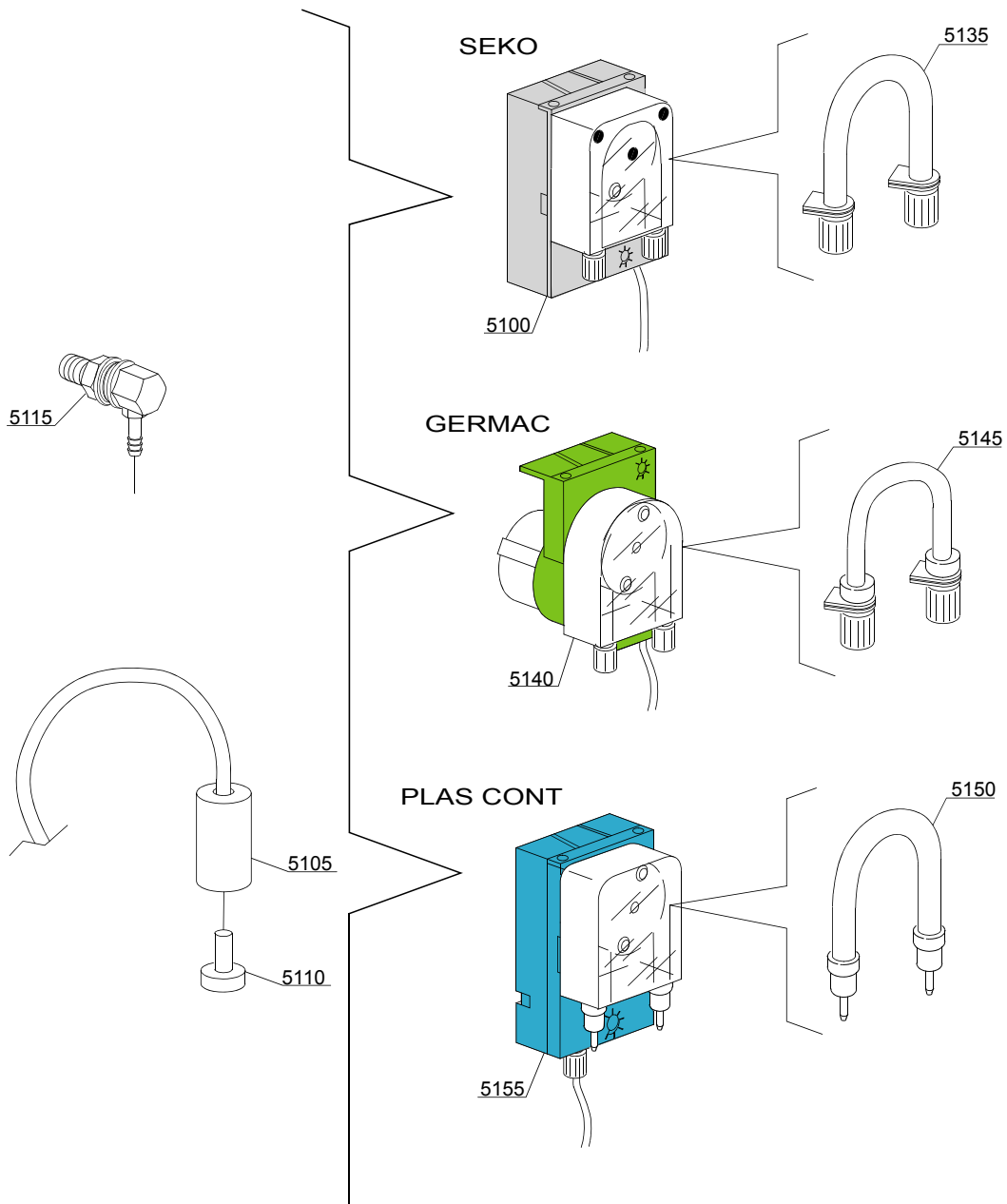

## Spare parts

ID	P-code	SN from	SN to	Mod.	Acces.	Volt	Description
<b>Module:Dosing detergent group</b>							
5100	15985		-	em	dd		Seko detergent pump
5105	12525		-	em	dd		Ballast
5110	15058		-	em	dd		Small filter (minimum 3 pieces)
5115	15123		-	em	dd		Compleat plastic injector
5135	15185		-	em	dd		Seko thermoplastic pipe
5140	15985		-	em	dd		Germac detergent pump
5145	15108/E		-	em	dd		Germac thermoplastic pipe
5150	15985/A			em	dd		Plas Cont thermoplastic pipe
5155	15985			em	dd		Plas Cont detergent pump

em=ELECTROMECHANICAL SWITCHES, lw=LOWER WASHING, uw=LOWER AND UPPER WASHING

102U=102U

bp=BOOSTER PUMP, dvgw=DVGW, cr=COLD RINSE, ws=WATER SOFTNER, dd=DETERGENT DISPENSER, dp=DRAIN PUMP

A=3/N/PE~380-400V 50-60Hz, D=3/PE~200-210V 50-60Hz, F=2/PE~220-240V 50-60Hz, G=3/N/PE~415V 50-60Hz, H=3/PE~220-230V 50-60Hz, K=3/PE~380-400V 50-60Hz, L=3/PE~415V 50-60Hz, M=3/PE~440V 60Hz, P=1/N/PE~220-230V 50-60Hz, R=2/PE~220-240V 50-60Hz, U=1/N/PE~240V 50-60Hz, V=3/PE~240V 50-60Hz, W=1/N/PE~100-110V 50-60Hz

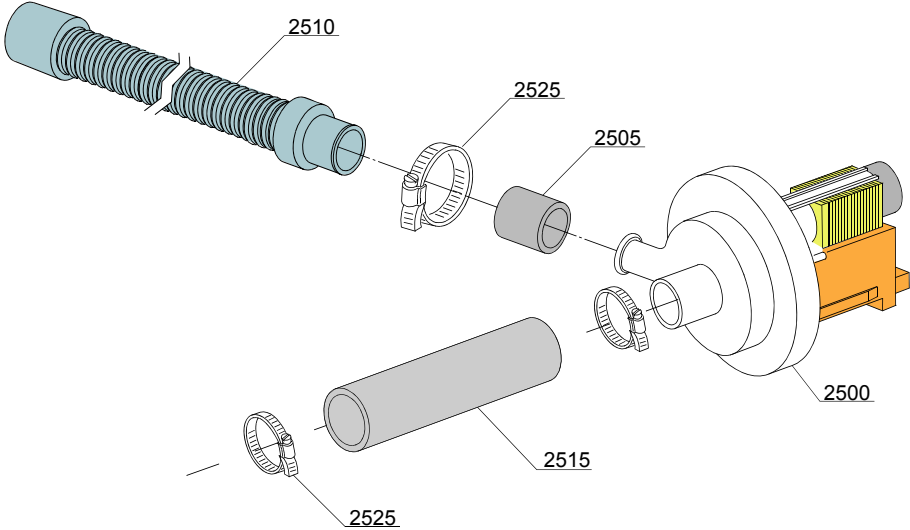

15\_004ce

## Spare parts

ID	P-code	SN from	SN to	Mod.	Acces.	Volt	Description
<b>Module:Drain pump group</b>							
2500	15101		-	em	dp		Drain pump 220/240V 50Hz
2500	15101/B		-	em	dp		Drain pump 220V 60Hz
2505	15101/D		-	em	dp		Pipe fitting (minimum 3 pieces)
2510	25031		-	em	dp		Drain pipe
2515	18044		-	em	dp		Ø28 top wash pipe
2525	11806		-	em	dp		25/40 clamp (minimum 2 pieces)

em=ELECTROMECHANICAL SWITCHES, lw=LOWER WASHING, uw=LOWER AND UPPER WASHING

102U=102U

bp=BOOSTER PUMP, dvgw=DVGW, cr=COLD RINSE, ws=WATER SOFTNER, dd=DETERGENT DISPENSER, dp=DRAIN PUMP

A=3/N/PE~380-400V 50-60Hz, D=3/PE~200-210V 50-60Hz, F=2/PE~220-240V 50-60Hz, G=3/N/PE~415V 50-60Hz, H=3/PE~220-230V 50-60Hz, K=3/PE~380-400V 50-60Hz, L=3/PE~415V 50-60Hz, M=3/PE~440V 60Hz, P=1/N/PE~220-230V 50-60Hz, R=2/PE~220-240V 50-60Hz, U=1/N/PE~240V 50-60Hz, V=3/PE~240V 50-60Hz, W=1/N/PE~100-110V 50-60Hz

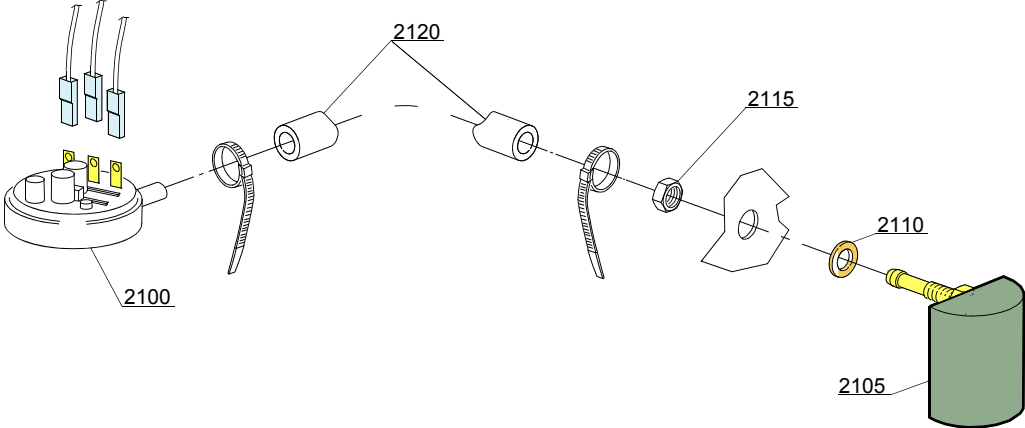

16\_001\_e



## Spare parts

ID	P-code	SN from	SN to	Mod.	Acces.	Volt	Description
<b>Module:Pressure switch group with air trap</b>							
2100	10706/A		-	em			47-27 pressure switch
2105	135911/B		-	em			Grey air trap assembly
2110	13301		-	em			O-ring (minimum 10 pieces) - D14x8x1,5
2115	11702		-	em			M8 stainless steel nut (minimum 10 pieces)
2120	14508		-	em			4,5X9 EPDM rubber hose (minimum 2mt)

em=ELECTROMECHANICAL SWITCHES, lw=LOWER WASHING, uw=LOWER AND UPPER WASHING

102U=102U

bp=BOOSTER PUMP, dvgw=DVGW, cr=COLD RINSE, ws=WATER SOFTNER, dd=DETERGENT DISPENSER, dp=DRAIN PUMP

A=3/N/PE~380-400V 50-60Hz, D=3/PE~200-210V 50-60Hz, F=2/PE~220-240V 50-60Hz, G=3/N/PE~415V 50-60Hz, H=3/PE~220-230V 50-60Hz, K=3/PE~380-400V 50-60Hz, L=3/PE~415V 50-60Hz, M=3/PE~440V 60Hz, P=1/N/PE~220-230V 50-60Hz, R=2/PE~220-240V 50-60Hz, U=1/N/PE~240V 50-60Hz, V=3/PE~240V 50-60Hz, W=1/N/PE~100-110V 50-60Hz

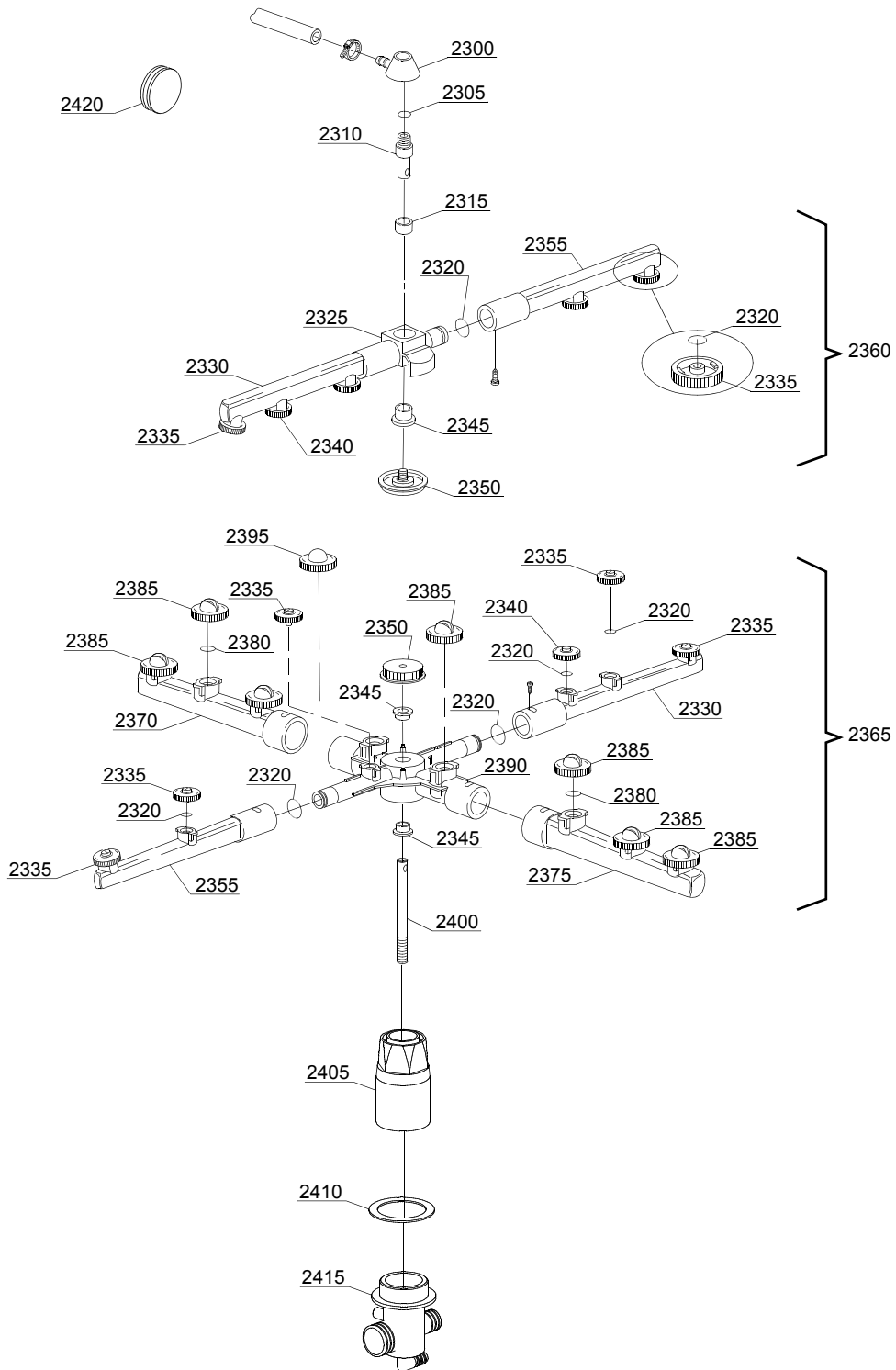

17\_139\_e

## Spare parts

ID	P-code	SN from	SN to	Mod.	Acces.	Volt	Description
<b>Module:Turret group with rotating arms</b>							
2300	350402		-	lw			Top turret rinse hub
2305	13003		-	lw			OR 112 NBR O-ring (minimum 10 pieces)
2310	350401		-	lw			Upper axle rinse hub
2315	13320		-	lw			Sliding washer (minimum 3 pieces)
2320	13002		-	lw			OR R6 NBR O-ring (minimum 10 pieces)
2325	10373		-	lw			Top hub for rotor
2330	10375		-	lw			Left rinse pipe
2335	10371		-	lw			Opened rinse nozzle (minimum 5 pieces)
2340	10372		-	lw			Closed rinse nozzle (minimum 2 pieces)
2345	13319		-	lw			Sliding washer (minimum 2 pieces)
2350	10377		-	lw			Handle with insert
2355	10374		-	lw			Right rinse pipe
2360	10997		-	lw			Top rinse group
2365	540999		-	lw			Wash/rinse group
2370	10367		-	lw			Right wash pipe
2375	10368		-	lw			Left wash pipe
2380	13009		-	lw			OR 2050 NBR O-ring (minimum 40 pieces)
2385	10369		-	lw			Opened rinse nozzle (minimum 2 pieces)
2390	10376		-	lw			Wash rotor
2395	10370		-	lw			Closed wash nozzle (minimum 2 pieces)
2400	25011		-	lw			Lower stainless steel ground axle RL/09
2405	25007		-	lw			Bell-shape RL/09
2410	25010		-	lw			RL/09 O-ring (minimum 5 pieces)
2415	25005		-	lw			Lower grey wash turret RL/09
2420	25013		-	lw			O-ring closed RL/09

em=ELECTROMECHANICAL SWITCHES, lw=LOWER WASHING, uw=LOWER AND UPPER WASHING  
102U=102U

bp=BOOSTER PUMP, dvgw=DVGW, cr=COLD RINSE, ws=WATER SOFTNER, dd=DETERGENT DISPENSER,  
dp=DRAIN PUMP

A=3/N/PE~380-400V 50-60Hz, D=3/PE~200-210V 50-60Hz, F=2/PE~220-240V 50-60Hz, G=3/N/PE~415V 50-60Hz,  
H=3/PE~220-230V 50-60Hz, K=3/PE~380-400V 50-60Hz, L=3/PE~415V 50-60Hz, M=3/PE~440V 60Hz, P=1/N/PE~220-  
230V 50-60Hz, R=2/PE~220-240V 50-60Hz, U=1/N/PE~240V 50-60Hz, V=3/PE~240V 50-60Hz, W=1/N/PE~100-110V  
50-60Hz

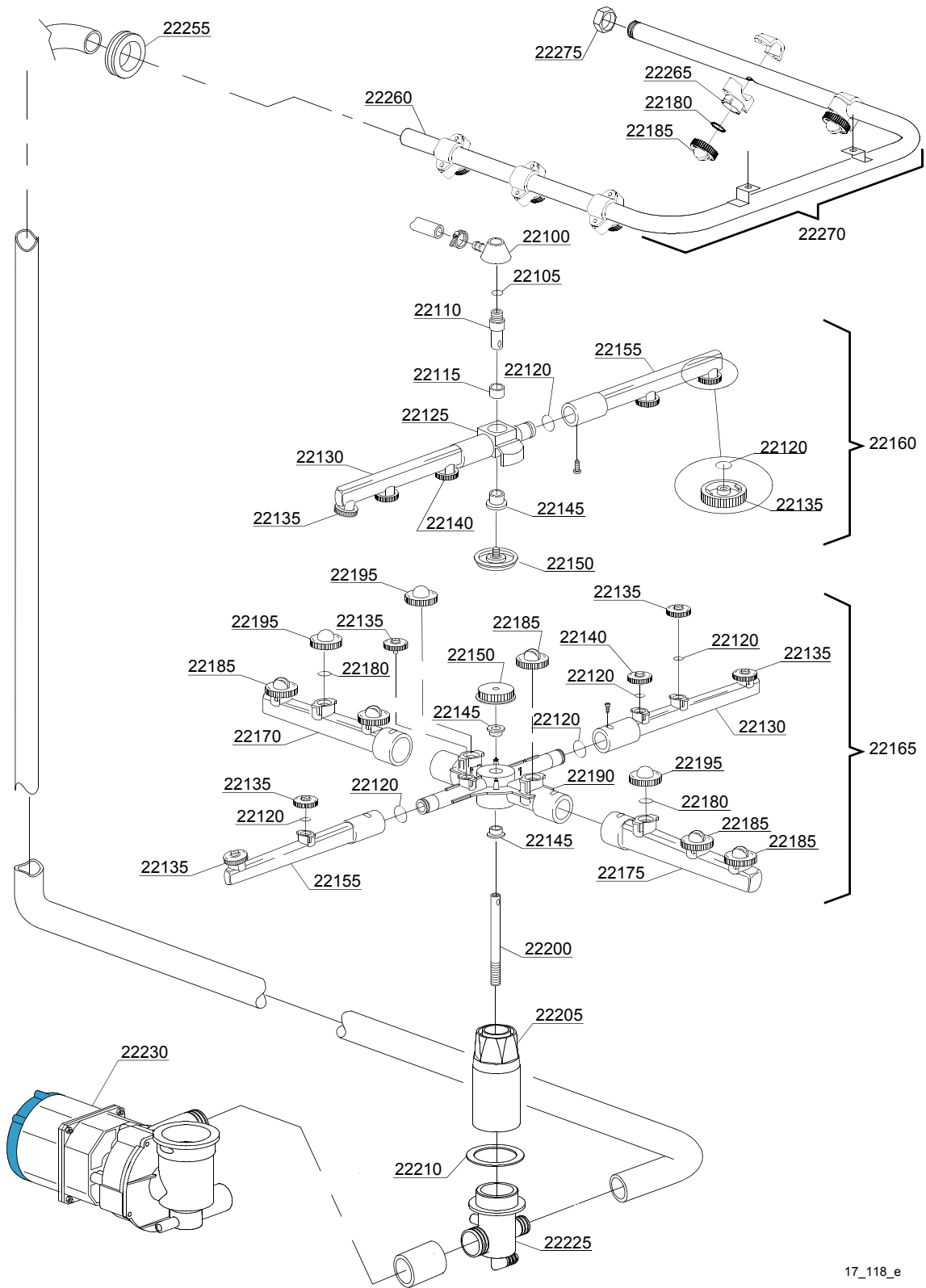

17\_118\_e

## Spare parts

ID	P-code	SN from	SN to	Mod.	Acces.	Volt	Description
<b>Module:Turret group with rotating arms</b>							
22100	350402		-	uw			Top turret rinse hub
22105	13003		-	uw			OR 112 NBR O-ring (minimum 10 pieces)
22110	350401		-	uw			Lower axle rinse hub
22115	13320		-	uw			Sliding washer (minimum 3 pieces)
22120	13002		-	uw			OR R6 NBR O-ring (minimum 10 pieces)
22125	10373		-	uw			Top hub for rotor
22130	10375		-	uw			Left rinse pipe
22135	10371		-	uw			Opened head rinse nozzle (minimum 5 pieces)
22140	10372		-	uw			Closed head rinse nozzle (minimum 2 pieces)
22145	13319		-	uw			Sliding washer (minimum 2 pieces)
22150	10377		-	uw			Handle with insert
22155	10374		-	uw			Right rinse pipe
22160	10997		-	uw			Top rinse group
22165	540996		-	uw			Lower wash/rinse group
22170	10367		-	uw			Right wash pipe
22175	10368		-	uw			Left wash pipe
22180	13009		-	uw			OR 2050 NBR O-ring (minimum 40 pieces)
22185	10378		-	uw			Opened head wash nozzle (minimum 2 pieces)
22190	540043		-	uw			Wash rotor
22195	10370		-	uw			Closed head wash nozzle (minimum 2 pieces)
22200	25012		-	uw			Stainless steel ground axle
22205	25007		-	uw			Bell-shape RL/09
22210	25010		-	uw			O-ring (minimum 5 pieces)
22225	25006		-	uw			Lower wash turret LS
22230	25024		-	uw			250W wash pump - 230V 50Hz
22230	25025		-	uw			250W wash pump - 220V 60Hz
22230	25026		-	uw			250W wash pump - 110V 60Hz
22555	25014		-	uw			Top wash ramp O-ring

em=ELECTROMECHANICAL SWITCHES, lw=LOWER WASHING, uw=LOWER AND UPPER WASHING

102U=102U

bp=BOOSTER PUMP, dvgw=DVGW, cr=COLD RINSE, ws=WATER SOFTNER, dd=DETERGENT DISPENSER, dp=DRAIN PUMP

A=3/N/PE~380-400V 50-60Hz, D=3/PE~200-210V 50-60Hz, F=2/PE~220-240V 50-60Hz, G=3/N/PE~415V 50-60Hz, H=3/PE~220-230V 50-60Hz, K=3/PE~380-400V 50-60Hz, L=3/PE~415V 50-60Hz, M=3/PE~440V 60Hz, P=1/N/PE~220-230V 50-60Hz, R=2/PE~220-240V 50-60Hz, U=1/N/PE~240V 50-60Hz, V=3/PE~240V 50-60Hz, W=1/N/PE~100-110V 50-60Hz

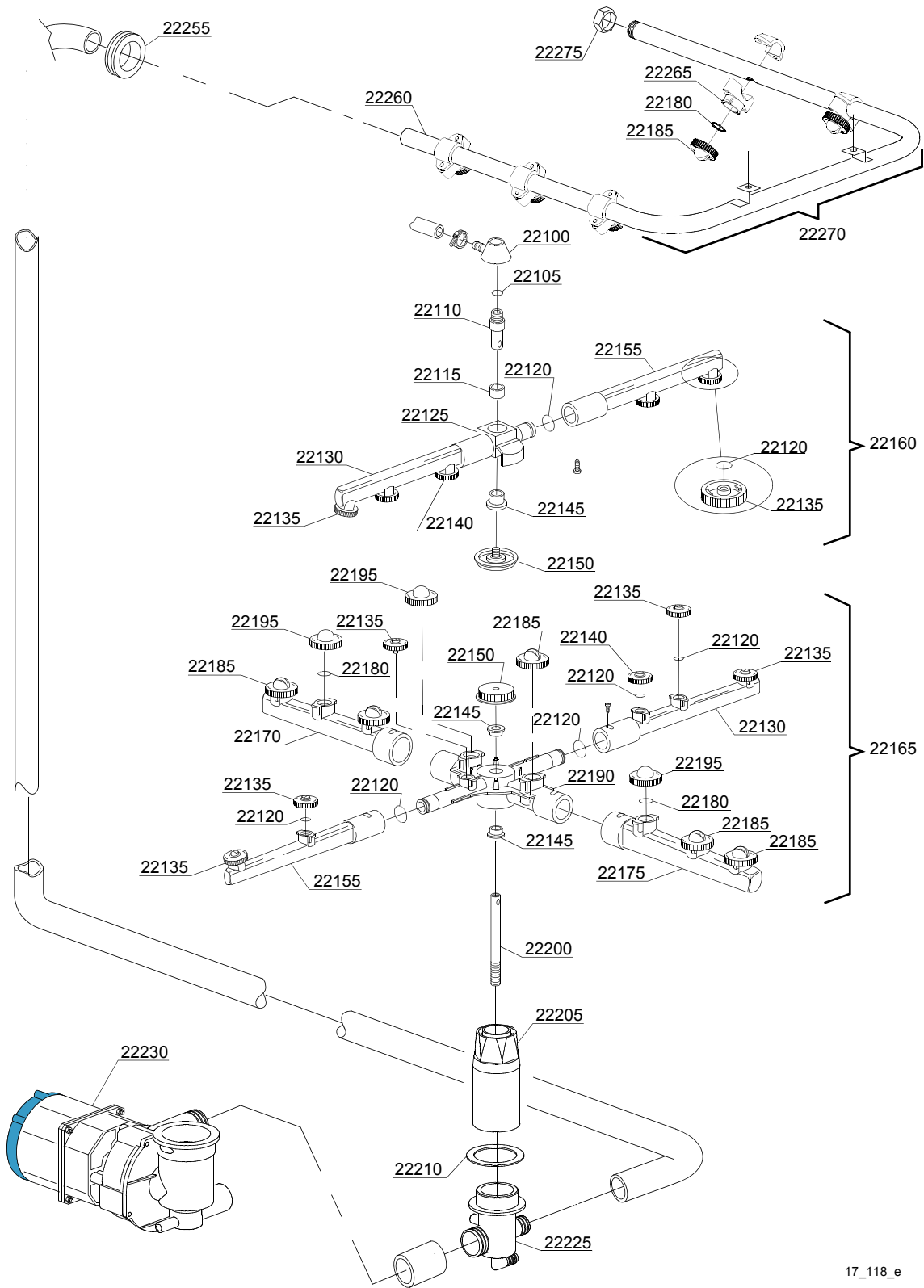

17\_118\_e

## Spare parts

ID	P-code	SN from	SN to	Mod.	Acces.	Volt	Description
<b>Module:Turret group with rotating arms</b>							
22265	10275		-	uw			Wash nozzle
22270	25016		-	uw			Top wash group
22275	12503		-	uw			Plug

em=ELECTROMECHANICAL SWITCHES, lw=LOWER WASHING, uw=LOWER AND UPPER WASHING

102U=102U

bp=BOOSTER PUMP, dvgw=DVGW, cr=COLD RINSE, ws=WATER SOFTNER, dd=DETERGENT DISPENSER, dp=DRAIN PUMP

A=3/N/PE~380-400V 50-60Hz, D=3/PE~200-210V 50-60Hz, F=2/PE~220-240V 50-60Hz, G=3/N/PE~415V 50-60Hz, H=3/PE~220-230V 50-60Hz, K=3/PE~380-400V 50-60Hz, L=3/PE~415V 50-60Hz, M=3/PE~440V 60Hz, P=1/N/PE~220-230V 50-60Hz, R=2/PE~220-240V 50-60Hz, U=1/N/PE~240V 50-60Hz, V=3/PE~240V 50-60Hz, W=1/N/PE~100-110V 50-60Hz