

Pelatore universale mod.PLF/10V2-18V2 - Pelapatate mod.PPF/10-18 - Lavacozze mod.LCF/10-18

Universal peeler mod.PLF/10V2-18V2 - Potato peeler mod.PPF/10-18 - Mussel washer mod.LCF/10-18

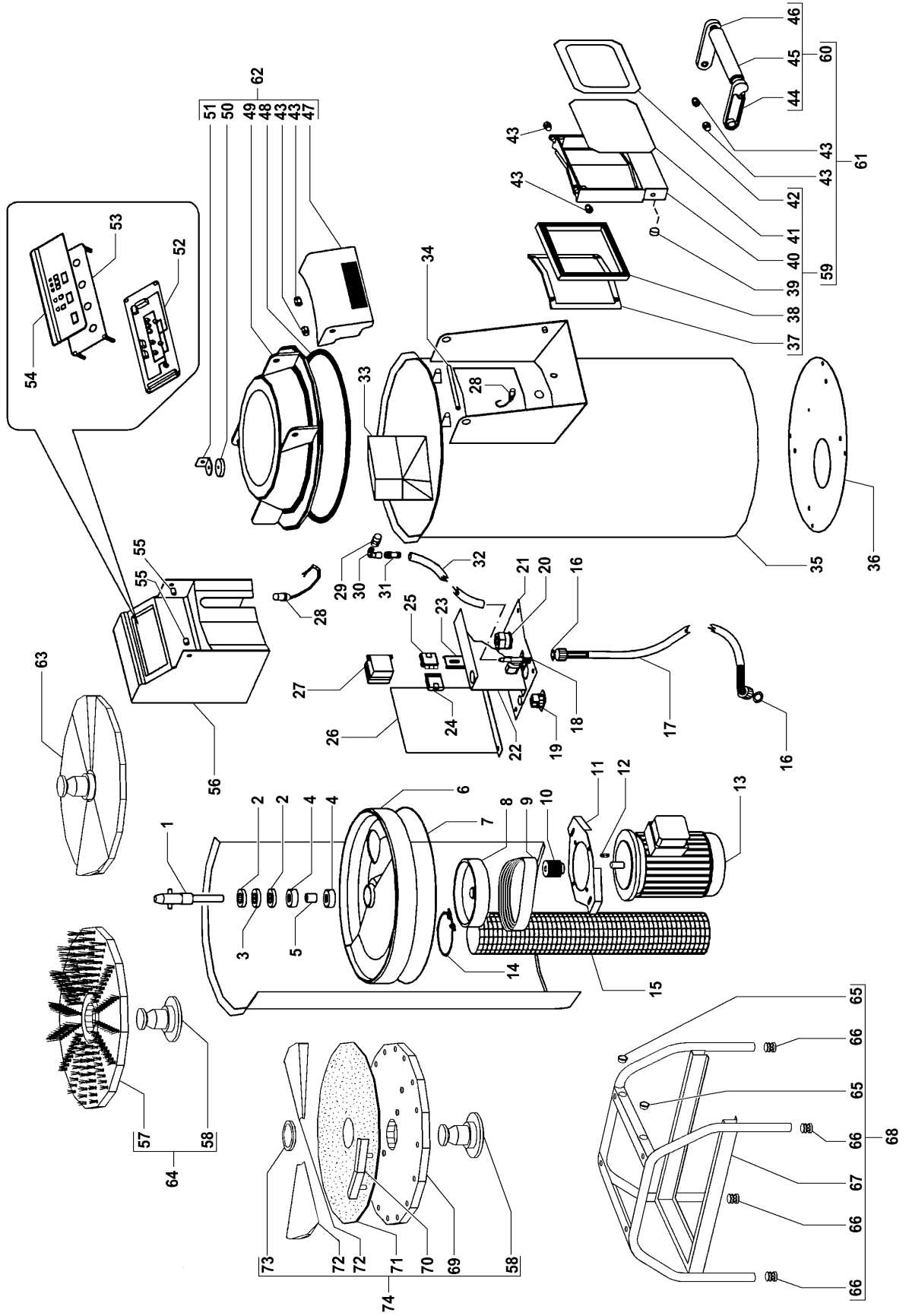

**PELATORE UNIVERSALE - PELAPATATE - LAVACOZZE MOD.PLF-PPF-LCF/10-18
UNIVERSAL PEELER - POTATO PEELER - MUSSEL WASHER MOD.PLF-PPF-LCF/10-18**

RIF.	CODICE / CODE	DIN - UNI	DESCRIZIONE / DESCRIPTION
1	36G6590		Albero / Shaft
2	3151300	28x42x7	Paraolio / Oil seal
3	3190830		Rosetta / Spacer
4	36F0090	6302 2RS	Cuscinetto / Bearing
5	36G5950		Boccola / Bush
6	3600870		Fondo / Bottom
7	3151750		Anello / Ring
8	36G6600		Puleggia mod.PLF-PPF / Pulley mod.PLF-PPF
8	SL1619		Puleggia mod.LCF / Pulley mod.LCF
9	36G6610		Cinghia / Belt
10	36G6620		Puleggia mod.PLF-PPF / Pulley mod.PLF-PPF
10	36G0030		Puleggia mod.LCF / Pulley mod.LCF
11	35V1230		Staffa / Bracket
12	SL0010	5x5x20	Linguetta / Key
13	SL0040	230-400V/3Ph/50Hz	Motore trifase mod.PPF/10 / Triple-phase motor mod.PPF/10
13	SL0041	230V/1Ph/50Hz	Motore monofase mod.PPF/10 / Single-phase motor mod.PPF/10
13	32M0170	230-400V/3Ph/50Hz	Motore trifase mod.PPF/18 / Triple-phase motor mod.PPF/18
13	32M0200	230V/1Ph/50Hz	Motore monofase mod.PPF/18 / Single-phase motor mod.PPF/18
13	SL1521	230-400V/3Ph/50Hz	Motore trifase mod.LCF/10 / Triple-phase motor mod.LCF/10
13	SL1523	230V/1Ph/50Hz	Motore monofase mod.LCF/10 / Single-phase motor mod.LCF/10
13	SL1522	230-400V/3Ph/50Hz	Motore trifase mod.LCF/18 / Triple-phase motor mod.LCF/18
13	SL1524	230V/1Ph/50Hz	Motore monofase mod.LCF/18 / Single-phase motor mod.LCF/18
13	32M4080	400V/3Ph/50Hz	Motore 2 velocità mod.PLF/10V2 / 2 speed motor mod.PLF/10V2
13	32M4050	400V/3Ph/50Hz	Motore 2 velocità mod.PLF/18V2 / 2 speed motor mod.PLF/18V2
14	3140460	ø88÷ø96	Fascetta / Clip
15	35X1150	ø90	Tube / Hose
16	3151550	ø15xø25x3	Guarnizione / Washer
17	33M0010	3/4" F-F	Tube / Hose
18	33D1371	230V/50-60Hz 3/4"	Elettrovalvola / Electro-valve
19	32D0360		Fissacavo / Cable clamp
20	32D1090	PG21	Pressaguaina / Sheathing clamp
21	35Q8620		Chiusura / Plate
22	35V8601		Setto / Dividing head
23	32D0630		Profilato / Structural shape
24	32D1010	1Ph+N+Gnd - M	Connettore monofase / Single-phase connector
24	32D1030	3Ph+N+Gnd - M	Connettore trifase / Triple-phase connector
25	32D1020	1Ph+N+Gnd - F	Connettore monofase / Single-phase connector
25	32D1040	3Ph+N+Gnd - F	Connettore trifase / Triple-phase connector
26	35M8840		Chiusura / Plate
27	32Z4840	230V/50-60Hz 3kW	Teleruttore / Remote control switch
28	32W3240		Microinterruttore / Microswitch
29	33Q6210	1/4" M-F	Raccordo / Joint
30	33Q6040	L 90° 1/4" M-F	Raccordo / Joint
31	33Q5180	1/4" M ø12	Portagomma / Cluch
32	33M0960	ø12	Tube / Hose
33	36D9660		Saltarello / Leaper
34	36G2040		Perno / Pivot
35	30W2930		Involucro mod.PLF-PPF-LCF/10 / Housing mod.PLF-PPF-LCF/10
35	30W3010		Involucro mod.PLF-PPF-LCF/18 / Housing mod.PLF-PPF-LCF/18
36	35D7790		Fondo / Bottom
37	36C0011		Cornice / Frame
38	37Q7860		Guarnizione / Washer
39	3600160		Magnete / Magnet
40	36Z6531		Porta / Door
41	35G4730		Chiusura / Plate
42	SL1507		Pannello adesivo / Adhesive panel
43	36D9550		Boccola / Bush
44	36M5100		Terminale sinistro / Left terminal
45	36M5110		Terminale destro / Right terminal
46	36M5120		Maniglia / Handle
47	36M5090		Maniglia / Handle
48	37Q7330		Guarnizione / Washer
49	36Z6501		Coperchio / Cover
50	3600310		Magnete / Magnet
51	35V6381		Staffa / Bracket
52	32Z3030		Scheda elettronica / electronic card
53	30A3560		Cruscotto / Dashboard
54	SL1504		Pannello adesivo mod.PPF-LCF / Adhesive panel mod.PPF-LCF
54	SL1505		Pannello adesivo mod.PLF / Adhesive panel mod.PLF
55	36D7310		Boccola / Bush
56	36Z0690		Cruscotto / Dashboard

(*): fuori produzione / out of production

**PELATORE UNIVERSALE - PELAPATATE - LAVACOZZE MOD.PLF-PPF-LCF/10-18
UNIVERSAL PEELER - POTATO PEELER - MUSSEL WASHER MOD.PLF-PPF-LCF/10-18**

RIF.	CODICE / CODE	DIN - UNI	DESCRIZIONE / DESCRIPTION
57	36G6880		Piattello spazzole / Brushes disk
58	36M5250		Pomello / Knob
59	6000930		Gruppo sportello / Door (assembly)
60	6005400		Gruppo maniglia / Handle (assembly)
61	6005390		Gruppo sportello / Door (assembly)
62	6005380		Gruppo Coperchio / Cover (assembly)
63	ACPAB		Piattello patate / Potato disk
64	ACPPC		Piattello cozze / Mussel disk
65	SL1919		Piedino / Foot
66	36G0750		Boccola / Bush
67	SL1625		Telaio / Chassis
68	ACCI		Gruppo telaio / Chassis (assembly)
69	SL2135		Disco / Disk
70	SL2137		Settore / Sector
71	SL2494		Tela abrasiva / Emery cloth
72	SL2136		Saltarello / Leaper
73	SL2138		Anello / Ring
74	ACPAT		Piattello patate / Potato disk
(*) : fuori produzione / out of production			