



Installer/ user manual

▶▶ CRISTAL FM1-FM2

Rack oven



Translated manual
Language: ENGLISH
Code: AF220045170-17
Date: 09/2016

Ladies and gentlemen,

You have just purchased one of our Pavailler products.

We wish to thank you for the confidence you have placed in our products.

These products are the result of extensive studies and testing to ensure your full satisfaction.

Our sales and after sales teams are always available to help you install, start up and use the product under optimum conditions.

WARRANTY CONDITIONS ON THE FRENCH MARKET

This document contains the conditions and recommendations for installing, using and maintaining our equipment.

Pavailler equipment has a one year warranty for parts and labour.

Certain works requiring the intervention of a specialised technician may only be performed by Pavailler's after sales service or one of our authorised dealers.

Any modifications to the equipment and non-observance of the recommendations of use stated above shall release Pavailler from all liability and make the warranty null and void.

For further information, please contact our technicians or authorised dealers.

In a continuous quest for improvements S.E.B.P. reserves the right to modify the technical characteristics of its products without prior notice. Dimensions, visuals and weights are given by way of illustration.

PLEASE READ CAREFULLY BEFORE USING THE EQUIPMENT

- The customer must make sure that the premises where the equipment is to be installed have a suitable capacity, in compliance with the applicable rules and standards.
- There must be no flour accumulations in the vicinity of the oven.

LIMITING FLOUR DUST EMISSIONS

Flour, the main ingredient in dough, is also considered the main cause of respiratory diseases in the baking sector, such as colds and asthma.

In fact, dust developing during flour processing are one of the causes for different forms of colds or, more seriously, different types of asthma.

Below is a list of recommendations on how to limit flour dust formation in the bakery as much as possible:

- Use 25 kg bags instead of 50 kg bags and empty them in several steps.
- Place the open end of the bag on the bottom of the mixer bowl and pull it up gently, holding the other end.
- Reduce the height from which the flour drops as much as possible.
- Do not shake the empty bag, close it and gently roll it up to fold it.
- Add the flour into the mixer bowl after the water (never the other way round).
- Distribute the flour manually or by means of a sieve without throwing it.
- Clean the worktop with the dough cutter, do not use a brush or compressed air (air gun).
- Separate work clothes from normal clothes.
- Do not shake out or brush work clothes, wash them.
- Avoid draughts.
- When using the mixer stick to the programmed operation in first gear during the first two minutes of the mixing cycle.

This is when the most flour dust is emitted.

- When using the mixer shift back into first gear each time flour is added.
- It is preferable to use a vacuum cleaner with a dust filter and to perform the cleaning operations in damp conditions by using a scraper instead of brushes or rags.
- Wear a protective mask during the operations generating the most dust: loading the mixer bowl, using the hydraulic divider, flouring the dough pieces, etc.
- Use equipment specially designed for reducing dust emissions: mixer with anti-dust lid, hydraulic divider with anti-adhesion treatment, etc.

Other volatile substances can be harmful or dangerous to the operator's health, please consult the information given by the raw material supplier.



ENVIRONMENTAL PROTECTION

In compliance with the current regulations this symbol indicates that the product may not be disposed of with household waste at the end of its service life.

To protect the environment the product must be taken to a collection point suitable for its treatment, valorisation and recycling.

The user thus helps to preserve natural resources and to protect health.

TABLE OF CONTENTS

1.	IMPORTANT SAFETY INSTRUCTIONS	2
2.	GENERAL CHARACTERISTICS	3
2.1.	DESCRIPTION.....	3
2.2.	CONFORMITY DECLARATION	5
2.3.	FOOTPRINT.....	6
2.4.	LOCATION OF DATA PLATES	8
2.5.	HEAT RELEASE RATE	8
3.	INSTALLATION	9
3.1.	SETUP	9
3.2.	GAS CONNECTION AND BURNER ADJUSTMENT	14
3.3.	ELECTRICAL CONNECTIONS	18
3.4.	WATER CONNECTION.....	23
3.5.	SMOKE EXHAUST CONNECTION.....	23
3.6.	STEAM EXHAUST CONNECTION.....	23
3.7.	FRESH AIR INTAKE.....	23
3.8.	OIL CONNECTION AND BURNER ADJUSTMENT	23
4.	CONVERTING THE OVEN FOR USE WITH A DIFFERENT TYPE OF GAS	27
4.1.	RIELLO BURNER	27
4.2.	CUENODOR ELCO BURNER	27
5.	OPERATION AND INSTRUCTIONS FOR USE	28
5.1.	CONTROL PANEL.....	28
5.2.	TIMER	30
5.3.	TEMPERATURE REGULATOR.....	31
5.4.	START-UP	32
5.5.	BAKING TIME	32
5.6.	STARTING A BAKING CYCLE	33
5.7.	END OF BAKING CYCLE	33
5.8.	CLEANING OF THE OVEN	33
5.9.	ELECTRONIC CONTROL PANEL.....	35
6.	MAINTENANCE	45
7.	WIRING DIAGRAMS	46
7.1.	OIL/GAS 380/415V POWER DISTRIBUTION DIAGRAM	46
7.2.	OIL/GAS 208/230 POWER DISTRIBUTION DIAGRAM.....	47
7.3.	ELECTRIC 380/415V POWER DISTRIBUTION DIAGRAM.....	48
7.4.	ELECTRIC 208/230V POWER DISTRIBUTION DIAGRAM.....	49
7.5.	OIL/GAS FM1/2 POWER DISTRIBUTION DIAGRAM WITH SPEED VARIATOR	50
7.6.	ELECTRIC FM1/2 POWER DISTRIBUTION DIAGRAM WITH SPEED VARIATOR	51
7.7.	DELAT ELECTRIC VARIATOR	52
	ROOF DISTRIBUTION BOX WIRING	53
7.8.	OIL/GAS CONTROL DIAGRAM	54
7.9.	ELECTRIC CONTROL DIAGRAM.....	56
7.10.	CONTROL KEYBOARD.....	58
7.11.	OIL/GAS CONTROL DIAGRAM WITH PROTOUCH AND SPEED VARIATOR.....	60
7.12.	ELECTRIC CONTROL DIAGRAM WITH PROTOUCH AND SPEED VARIATOR	61
8.	PARTS LIST	62
8.1.	ELECTRIC OVEN GENERAL PARTS LIST	62
8.2.	OIL/GAS OVEN REAR PARTS LIST	64
8.3.	GENERAL PARTS LIST FOR OIL/GAS OVEN SIDE.....	66
8.4.	ROOF PARTS LIST 1/3	68
8.5.	ROOF PARTS LIST 2/3	70
8.6.	ROOF PARTS LIST 3/3	72
8.7.	DOOR UNIT PARTS LIST 1/3	74
8.8.	DOOR UNIT PARTS LIST 2/3	76
8.9.	DOOR UNIT PARTS LIST 3/3	78
8.10.	ELECTRIC HEATING UNIT	80
8.11.	OIL/GAS HEATING UNIT PARTS LIST	82

8.12.	HEATING UNIT PARTS LIST: MOTOR IMPELLER ASSEMBLY	84
8.13.	DAMPER PARTS LIST	86
8.14.	HEAT EXCHANGER PARTS LIST	88
8.15.	INCLINED PAN PARTS LIST	90
8.16.	STEAM EXHAUST FAN PARTS LIST	92
8.17.	SQUIRREL CAGE PARTS LIST	94
8.18.	CONTROL PANEL PARTS LIST	96
8.19.	ROOF DISTRIBUTION BOX PARTS LIST	99
8.20.	OIL/GAS 380/415V ELECTRICAL CABINET BACK PARTS LIST	100
8.21.	OIL/GAS 208/230V ELECTRICAL CABINET BACK PARTS LIST	102
8.22.	OIL/GAS ELECTRICAL CABINET PARTS LIST	104
8.23.	ELECTRIC M1E 380/415V ELECTRICAL CABINET BACK PARTS LIST	106
8.24.	ELECTRIC M1E 208/230V ELECTRICAL CABINET BACK PARTS LIST	108
8.25.	ELECTRIC M2E 380/415V ELECTRICAL CABINET BACK PARTS LIST	110
8.26.	ELECTRIC M2E 208/230V ELECTRICAL CABINET BACK PARTS LIST	112
8.27.	ELECTRIC M1 ELECTRICAL CABINET PARTS LIST	114
8.28.	M2 ELECTRICAL CABINET PARTS LIST	116
9.	EXPLODED VIEWS FOR ASSEMBLY	118
9.1.	ELECTRIC OVEN	118
9.2.	OIL/GAS OVEN REAR	121
9.3.	OIL/GAS OVEN SIDE	124
9.4.	ELECTRIC HEATING UNIT	127
9.5.	OIL/GAS HEATING UNIT	128
9.6.	HEAT EXCHANGER	129
9.7.	SQUIRREL CAGE	130
9.8.	OIL/GAS M1-M2 STEAM GENERATOR	131
9.9.	ELECTRIC M1-M2 STEAM GENERATOR	132
9.10.	ELECTRICAL CONNECTIONS	133
10.	ASSEMBLY	135
11.	ADJUSTMENTS	146
12.	STARTING THE OVEN	147
12.1.	MOTOR DIRECTION OF ROTATION	147
12.2.	ADJUST THE DOOR UNLOCKING CABLE	147
12.3.	CHECK THE DIRECTION OF THE DAMPER	147
12.4.	INSTALL THE CLADDING	147
13.	CHANGES FOR INSTALLING THE SQUIRREL CAGE	148
14.	CHANGES TO SETUP	151

1. IMPORTANT SAFETY INSTRUCTIONS

The oven is intended for professional use and must be operated by qualified personnel only.

The oven is exclusively designed for baking bread, confectionery and Viennese pastry. It should never be used for any other applications.

Never use flammable or explosive products inside the oven (e.g.: never clean the oven with flammable products; do not insert baking trays, pans or racks which still contain a flammable cleaning agent.)

The oven must be installed according to current regulations and standards. The gas, oil, water and voltage supply as well as the smoke and steam evacuation systems and their connections have to be carried out and maintained by qualified professionals in compliance with current regulations and standards (see section on installation). The cost of this work is borne by the customer.

The installation site of the oven must have appropriately sized fresh air inlets and contaminated air outlets (paid for by the customer) (see section "fresh air intake").

For oil or gas fired ovens it is forbidden to install additional mechanical ventilation devices (e.g.: window fan, extractor hood):

- in the room where the oven is installed
- in a separate room if this ventilation may lead to depression sufficient to cause a backflow of combustion fumes.

Do not use any burners other than the recommended models.

If a different type of gas is used, contact a qualified technician (see section "Converting the oven for use with a different type of gas").

2. GENERAL CHARACTERISTICS

2.1. DESCRIPTION

- CRISTAL ovens are rotary rack ovens that are compatible with:
 - without squirrel cage: Pavailler racks
 - with squirrel cage: any type of racks with a max. height of 1640 mm for M1 ovens and 1820 mm for M2 ovens.
- They operate on gas, oil with heat exchanger or electricity.
- Maximum oven capacity is 300 kg (rack included) without squirrel cage, and 225 kg (rack included) with squirrel cage.
- The oven is entirely made of stainless steel, including the steam exhaust fan - three stainless steel impellers – heat exchanger in refractory stainless steel.
- The front-mounted control panel features all the oven controls including the timer and baking temperature display.
- Steam injection time is adjustable with a timer.
- The baking chamber neon tubes light up automatically when the oven starts.

Reinforced insulation due to:

- . pre-insulated components at the factory
 - . systematic elimination of all thermal bridges
 - . door triple glazing
 - . door tightness with high-temperature gasket on all four sides
- All electric links are made with connectors
 - All motors are protected with a thermal overload switch.
 - Electric DAMPER controlled from the oven front (closes automatically when the oven stops).
 - Maximum oven safety with:
 - . cold walls including the door, the door frame and glazing
 - . patented integrated safety system: double-acting door unlocking:
 - **first step**: half-opening of door and automatic steam exhaust (hood integrated into the oven) - delayed and adjustable extraction time.
 - **second step**: full opening of door when the rack reaches its final unloading position.

Baking chamber usable dimensions:

M1: diameter 930 mm - M2: diameter 1130 mm

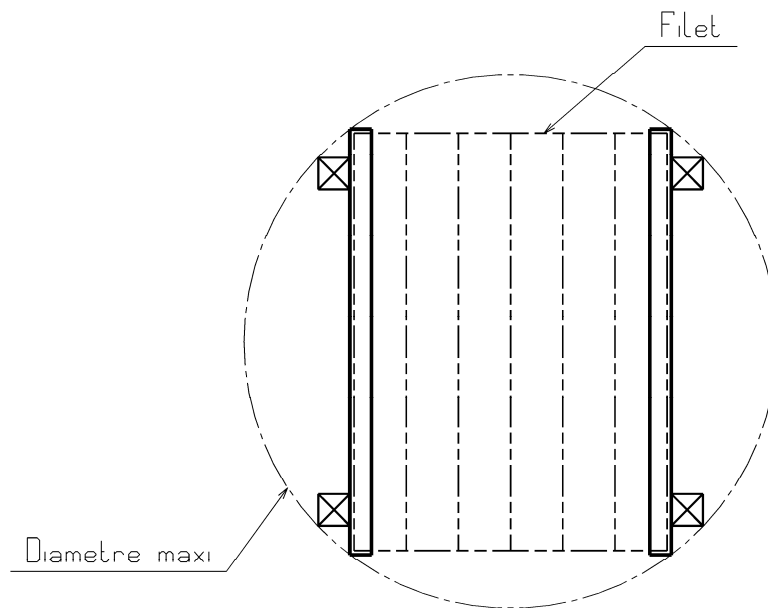
**Net weights:**

M1 Oil/Gas = 900 kg - Electric = 825 kg
M2 Oil/Gas = 1100 kg - Electric = 1025 kg

BAKCHAMDIM

Available voltages

- 208 to 240V 50/60 Hz
- 380 to 415V 50/60 Hz

2.2. CONFORMITY DECLARATION

<h1 style="margin: 0;">Pavailler</h1>	
CONFORMITY DECLARATION	
Déclaration de conformité Konformitäts Erklärung	Dichiarazione di conformità Declaracion de conformidad
CE	
<p>The Manufacturer : SEBP PAVAILLER - Le fabricant - Il costruttore - Der Hersteller - El fabricante BP 54 - Rue Benoit Frachon F - 26802 PORTES LES VALENCE</p>	
<p>Declares under its only responsibility that the brand new product here under described : - déclare, sous sa seule responsabilité, que le matériel neuf désigné ci-après : - dichiara, sotto la propria esclusiva responsabilità che il prodotto, nuovo di fabbrica : - erklärt, in seiner alleinigen Verantwortung die Konformität der nachfolgend aufgeführten Ware : - declara bajo su propia responsabilidad que el material descrito a continuación :</p>	
Machine for bakeries/confectioners	
Machine pour boulangerie/pâtisserie - Macchina per panificio/pasticceria - Maschine für Bäckerei/Feinbäckerei - Máquina para panadería/pastelería	
<p>Model : - Modèle - Modello - Modell - Modelo : Rack oven Four à chariots - - - Rack oven</p>	
<p>Type : Four à chariot - Type : - Tipo - Typ - Tipo :</p>	<p>Code : - Code : - Codice : - Code : - Código :</p>
<p>Serial - N° de série : - N° di serie : - Seriennr. - Número de serie :</p>	<p>Year of manufacture : - Année de fabrication : - Anno di costruzione : - Baujahr. - Año de fabricación :</p>
<p>is compliant with the following European Directives : - est conforme aux directives européennes suivantes : - mit den folgenden europäischen Richtlinien konform ist :</p>	
<p>2006/42/CE MACHINE DIRECTIVE 2006/42/CE Directive machines 2006/42/CE Maschinenrichtlinie</p>	<p>2006/42/CE Direttiva macchine 2006/42/CE Directiva de Máquinas</p>
<p>2004/108/CE DIRECTIVE CONCERNING THE ELECTROMAGNETIC COMPATIBILITY 2004/108/CE Directive compatibilité électromagnétique 2004/108/CE elektromagnetische Kompatibilitäts-Richtlinien</p>	
<p>2009/142/CE GAS DIRECTIVE when gas fired. In this case, the notified body is CERTIGAZ, 8 rue de l' Hotel de Ville - 92200 Neuilly sur Seine - FRANCE. His accreditation number is 1312 and the number of the certificate is - 2009/142/CE Directive gaz quand l'énergie est le gaz. Dans ce cas, l'organisme notifié est CERTIGAZ, 8 rue de l' Hotel de Ville - 92200 Neuilly sur Seine - FRANCE. Son numéro d'accréditation est le 1312 et le numéro du certificat est le - 2009/142/CE Gas-Richtlinie wenn Gas Energie. Dies wird durch CERTIGAZ, 8 rue de l' Hotel de Ville - 92200 Neuilly sur Seine - FRANCE, mit dem Zertifikat bestätigt. - 2009/142/CE Directiva gas cuando la energía es el gas. En este caso, el organismo notificado es CERTIGAZ, 8 rue de l' Hotel de Ville - 92200 Neuilly sur Seine - FRANCE. Su número de acreditación es el 1312 y el número del certificado es el</p>	
<p>REGULATION (EC) 1935/2004 of 27 october 2004 Under normal and foreseeable conditions of use not bringing about an unacceptable change in the composition or deterioration of the organoleptic characteristics of bread dough, the above mentioned machine is authorised for food contact in the bakery field. - Règlement (CE) 1935/2004 du 27 octobre 2004 La machine référencée ci-dessus, dans les conditions normales et prévisibles d'emploi n'entraînant aucune modification inacceptable de la composition ou une altération des caractères organoleptiques de la pâte à pain, est apte au contact alimentaire en boulangerie. - Verordnung (EG) 1935/2004 vom 27 October 2004 Unter normalen oder vorhersehbaren Verwendungsbedingungen, welche keine unverträgliche Veränderung der Zusammensetzung oder eine Beeinträchtigung der organoleptischen Eigenschaften des Brotteigs herbeiführen, ist die oben genannte Maschine für Lebensmittelkontakt in Bäckereibereich zugelassen.</p>	
<p>it is certify as before mentioned : - est certifié comme indiqué : - und ist mit folgenden Produktzertifizierungen ausgestattet :</p>	<p>- Ed è dotato delle seguenti certificazioni di prodotto : - y está certificado como sigue :</p>
<p>Only Yves Adrien, plant manager, is authorized to build up the technical file of this product. Mr Yves Adrien, directeur d'établissement, est seul autorisé à constituer le dossier technique de ce produit. Il Sig. Yves Adrien, direttore di stabilimento, è il solo autorizzato a costituire il fascicolo tecnico di questo prodotto. Mr Yves Adrien, Ausstellungsleiter, ist der Alleinberechtigte zur Bildung der technischen Akte dieses Produktes. Sr Yves Adrien, director de establecimiento, es sólo autorizado a constituir el expediente técnico de este producto.</p>	
<p>Portes-lès-Valence, le</p>	<p>Yves ADRIEN Plant manager - Directeur d'établissement - Direttore di stabilimento - Betriebsleiter - Director de establecimiento</p> 
<p>S.E.B.P. Société d'Équipement de Boulangerie-Pâtisserie Société par Actions Simplifiée au capital de 2 850 000 € Siège social : BP 54 - Rue Benoit Frachon - F-26802 Portes-lès-Valence Cedex -France Tél. : + 33 (0) 475 575 600 - Fax : + 33 (0) 475 572 318 - Web site :http://www.pavailler.com SIREN 478 895 034 - RCS Romans - N° TVA Intracommunautaire FR 17 478 895 034 - Code NAF: 2893 Z Lieu de juridiction : Le tribunal compétent du ressort de notre siège social.</p>	

2.3. FOOTPRINT

ELECTRIC - OIL / GAS M1 OVENS

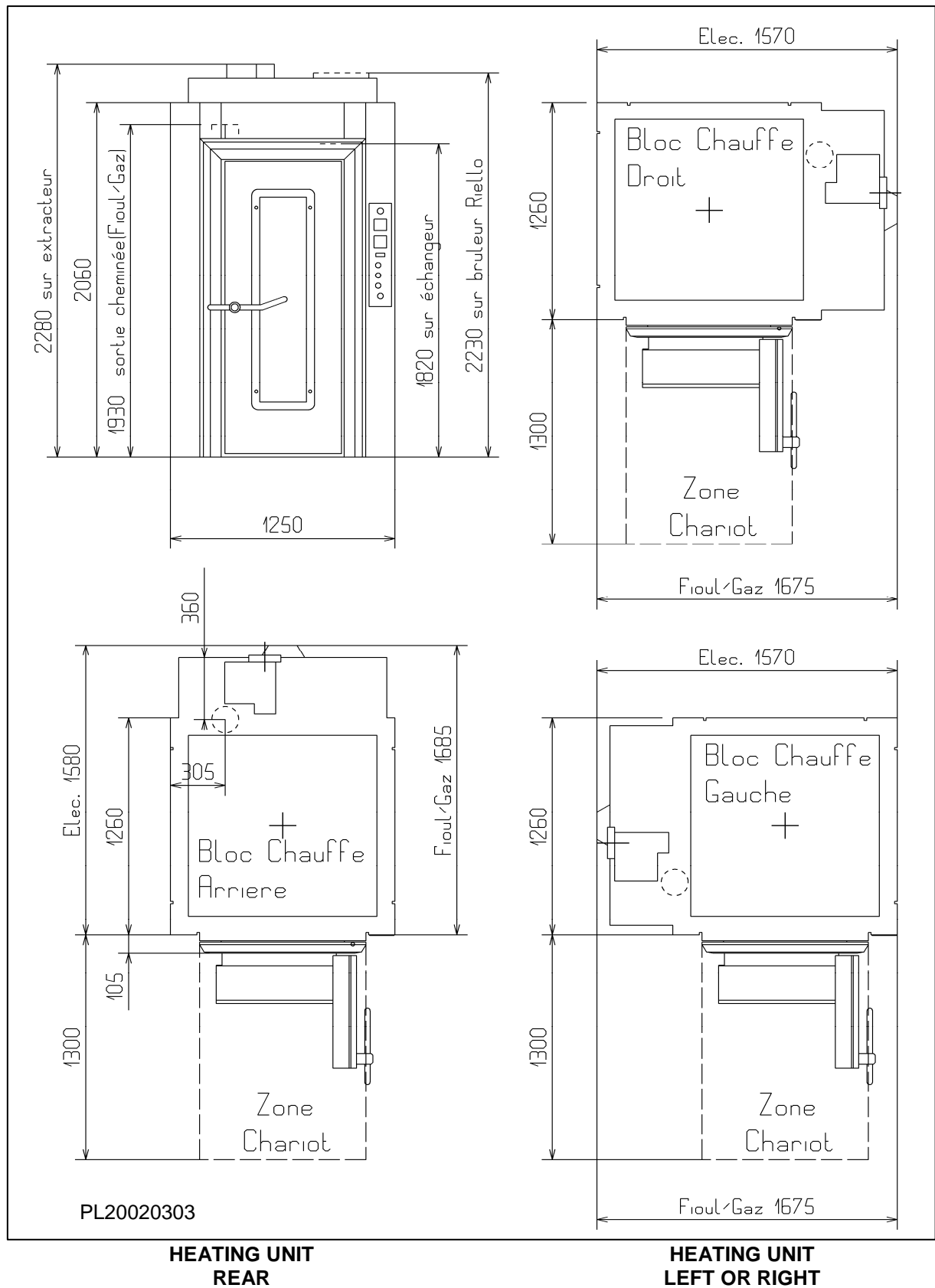

ELECTRIC - OIL/GAS M2 ovens

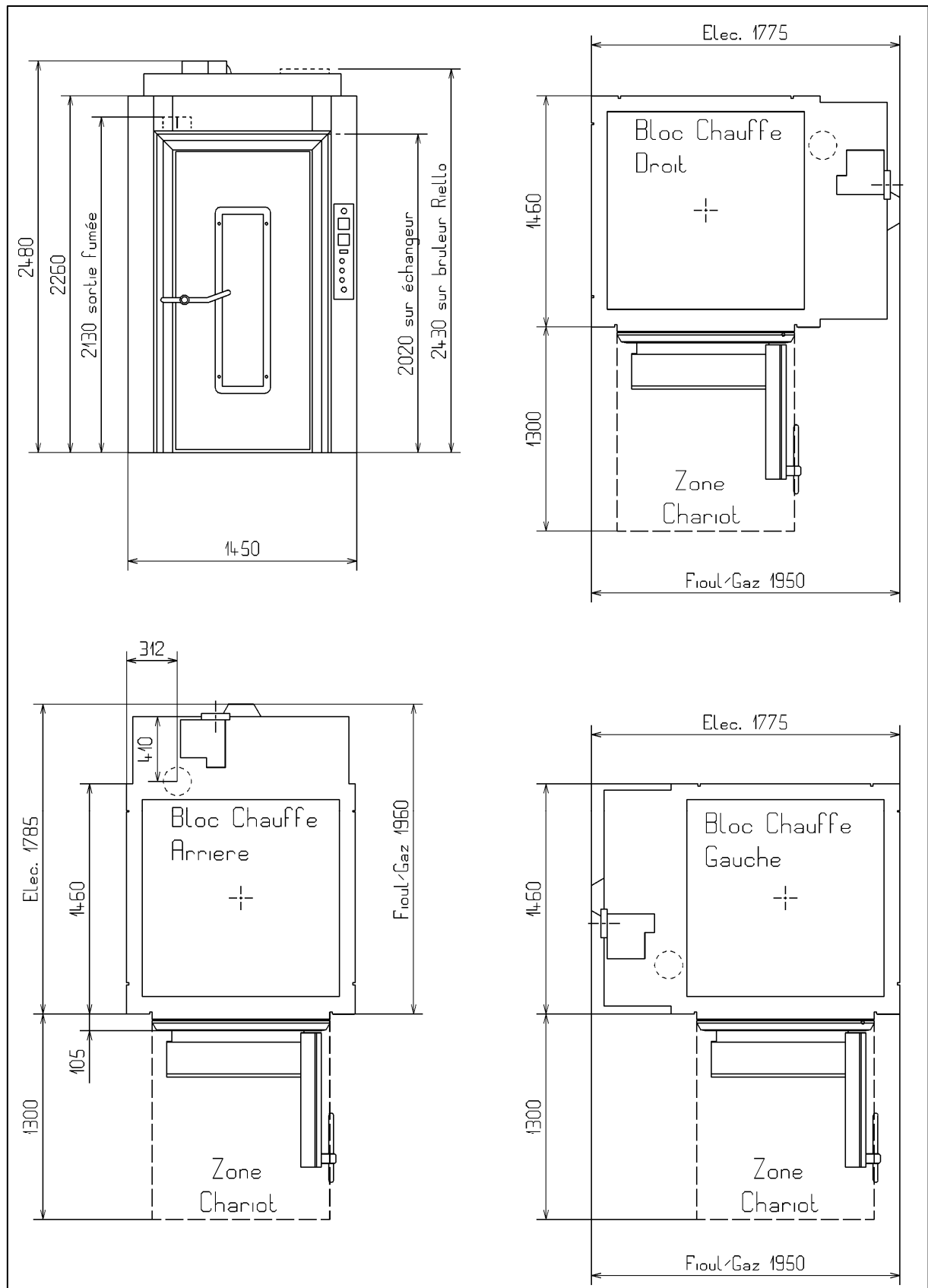

**HEATING UNIT
REAR**

**HEATING UNIT
LEFT OR RIGHT**

2.4. LOCATION OF DATA PLATES

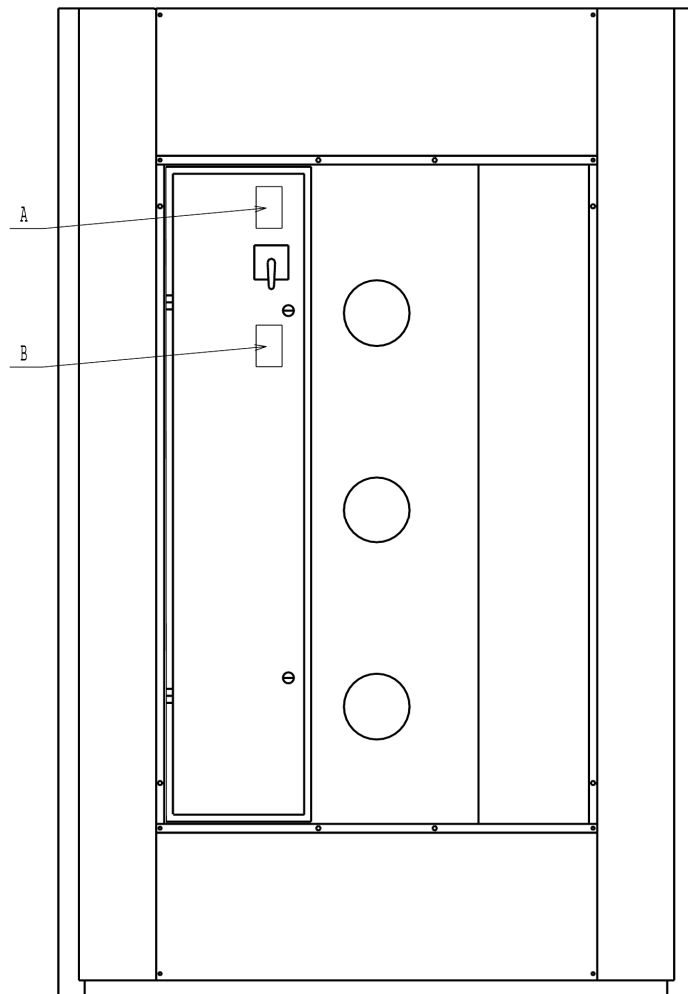
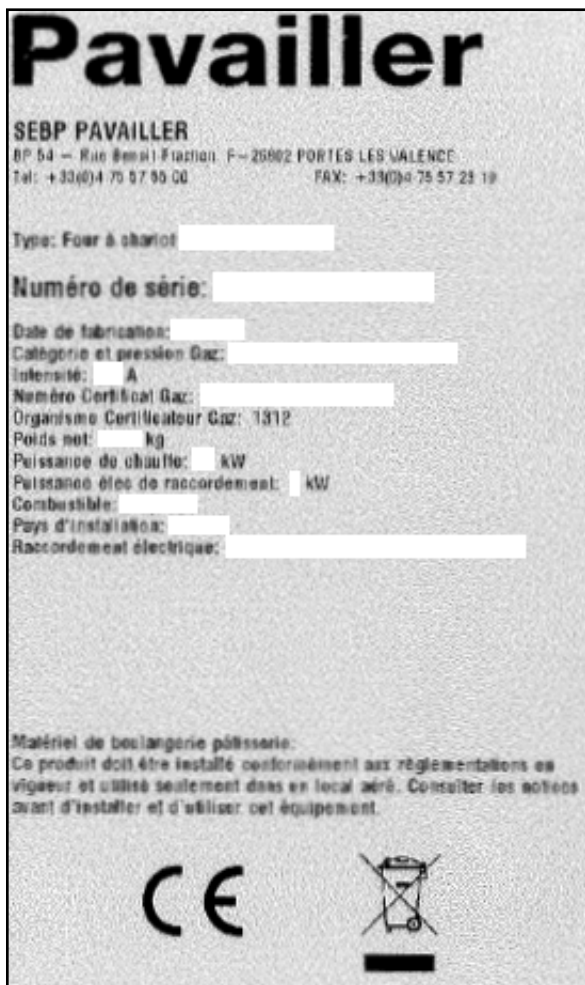

P120005876

A: Manufacturer's plate
 B: Gas rating plate

For gas supply pressure and type of gas, please consult the manual given by the burner builder (manufacturer) and the burner rating plate.

2.5. HEAT RELEASE RATE

Oven type reference	Rated heat release (Kw on Hi)
M1	47
M2	77

3. INSTALLATION

3.1. SETUP

3.1.1 Dimensions and weights of the bulkiest components

	M1	M2
Assembled roof O/G	990x990x530 106 kg	1190x1190x530 120 kg
Heating unit O/G	1950x990x530 140 kg	2150x1190x600 170 kg
Electric heating unit	1950x800x420 140 kg	2150x1000x490 170kg
Door unit	2060x970x350 150 kg	2260x1170x350 186 kg
Panel	1980x880x150 52 kg	2180x1080x150 72 kg

**3.1.2 Check that the installation site can withstand the oven's weight.
The floor should be even and level (check with a spirit level gauge).**

3.1.3 Handling

The assembled oven or assembled roof can be handled using slings, as per sketch.

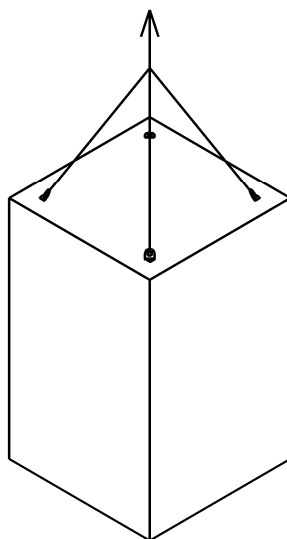

CUBEFM1P

Layout

M1 ELECTRIC OVENS

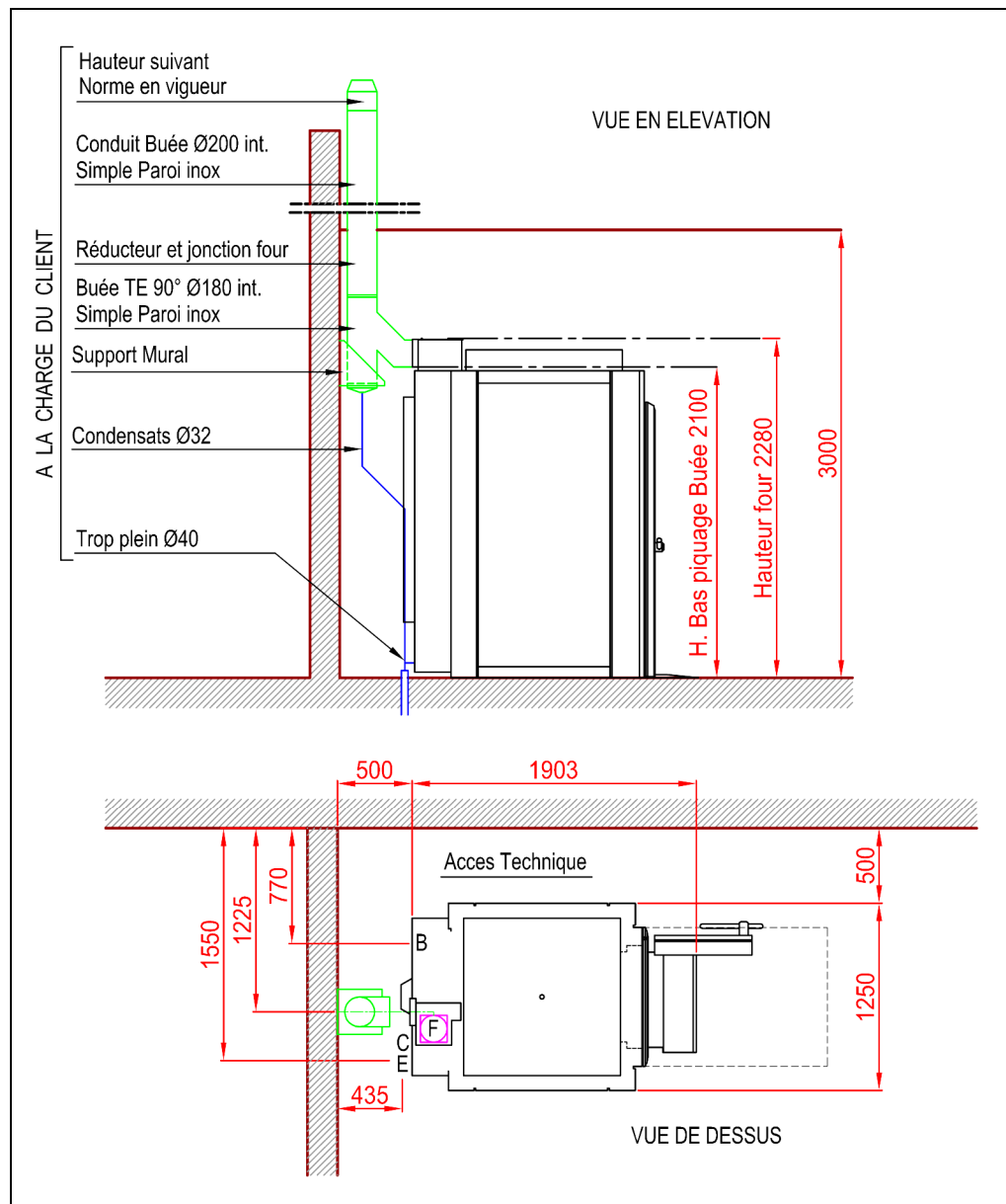

- B: 400V 3 phases +Earth
- C: Cold water inlet
- E: Waste water drain Ø30 min.
- F: Steam exhaust, horizontal Ø180mm outlet, towards the back of the oven

No flammable material within less than 16 cm from the 200°C steam exhaust.

OIL/GAS M1 OVENS

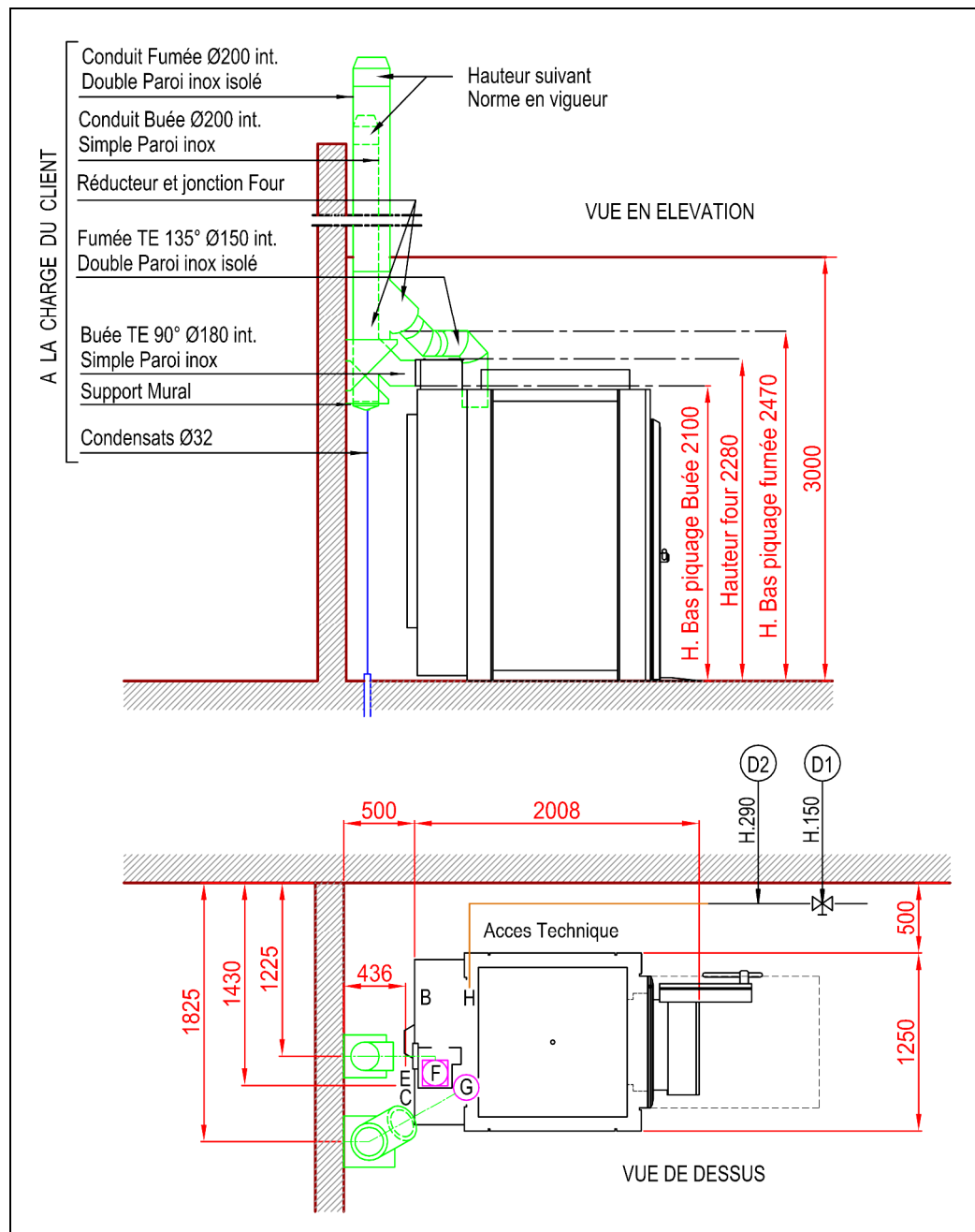

- B: 400V 3 phases +N+Earth
- C: Cold water inlet
- D1: Sectional valve
- E: Waste water drain Ø30 min.
- F: Steam exhaust, horizontal Ø180 mm outlet, towards the back of the oven
- G: Smoke outlet, Ø150 mm vertical
- H: Oil or gas

No flammable material within less than 16 cm from the 200°C steam exhaust.

ELECTRIC M2 OVENS

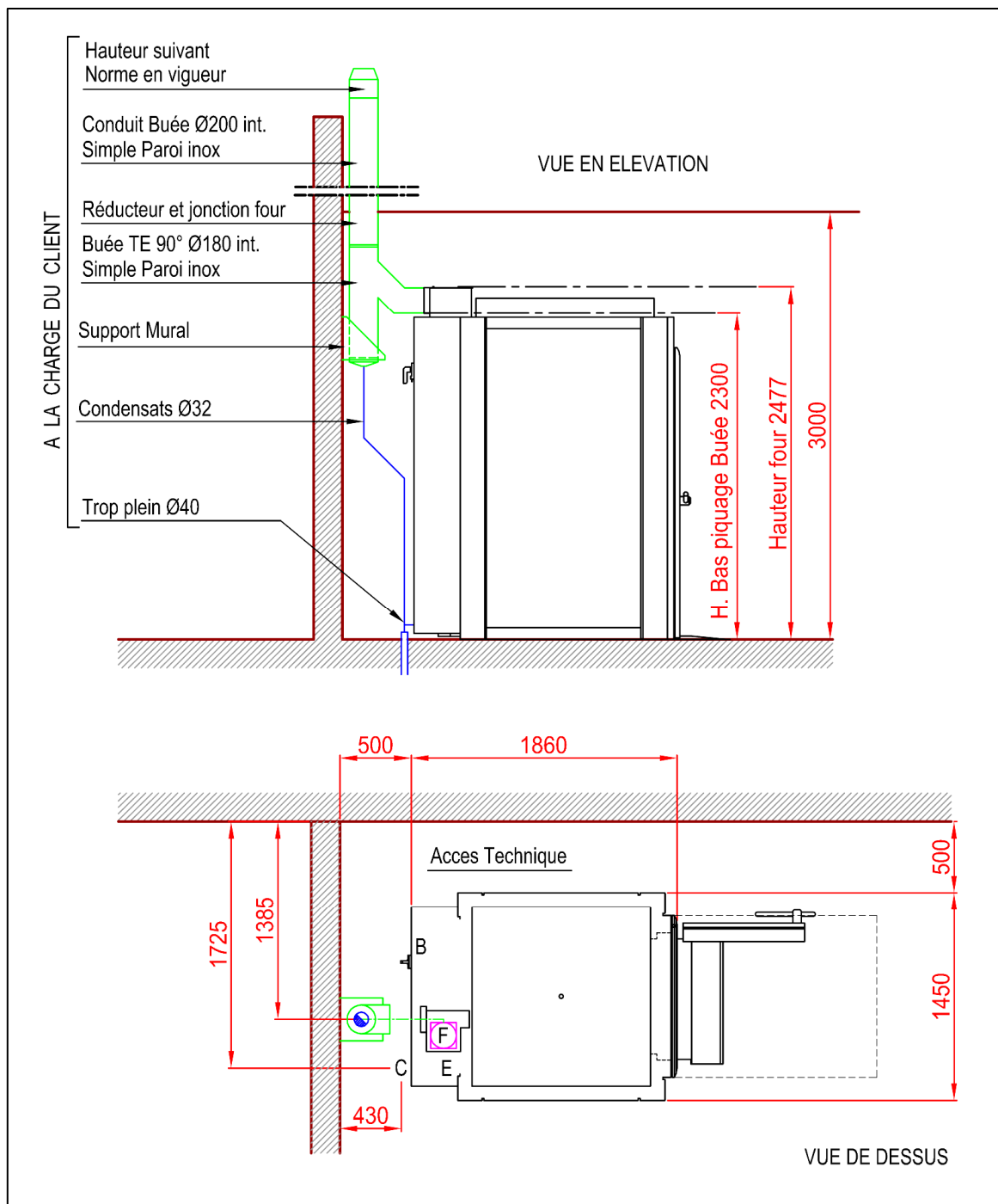

- B: 400V 3 phases +Earth
- C: Cold water inlet
- E: Waste water drain Ø30 min.
- F: Steam exhaust, horizontal Ø180 mm outlet, towards the back of the oven

No flammable material within less than 16 cm from the 200°C steam exhaust

M2 OIL/GAS OVENS

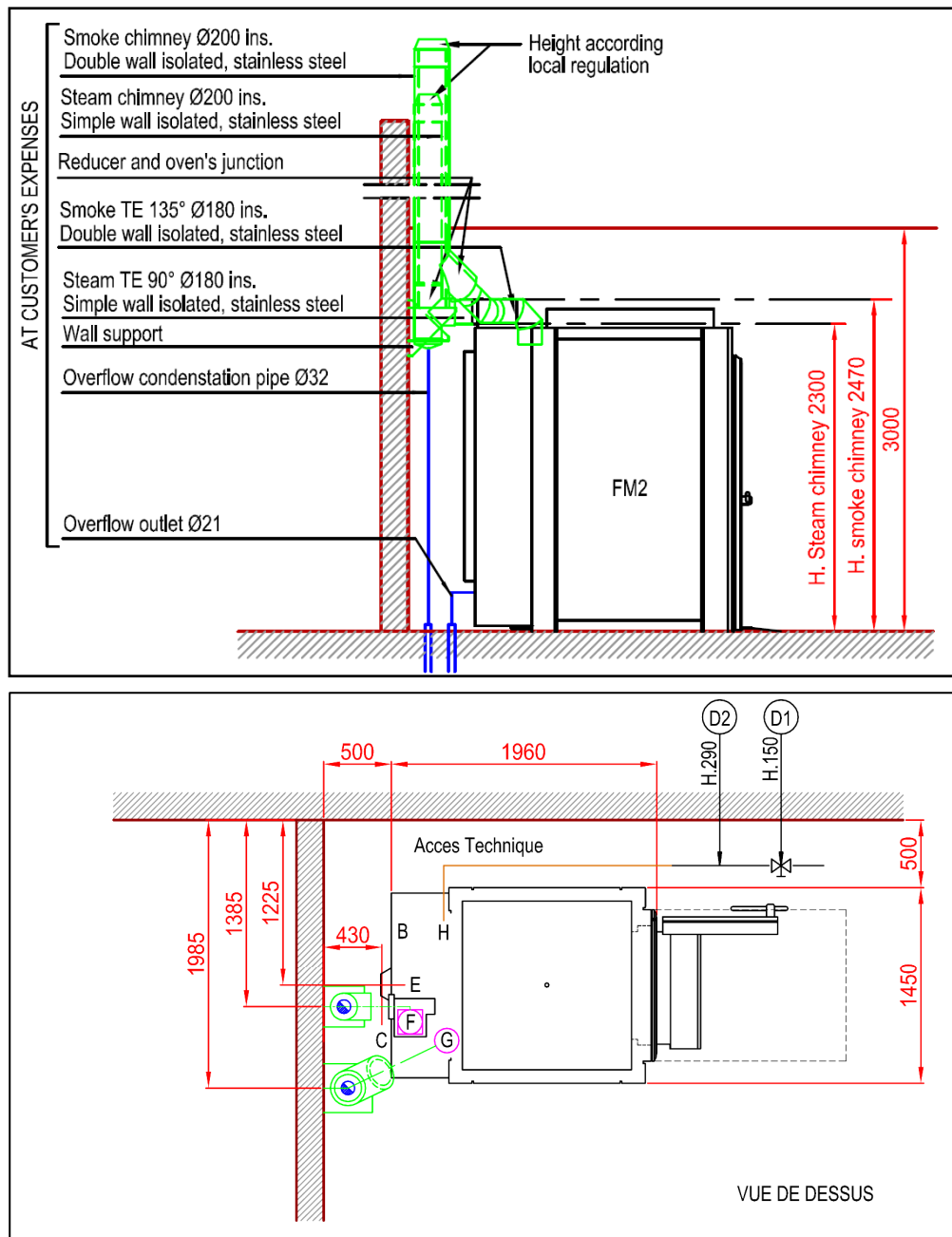

PL20020307

- B: 400V 3 phases +N+Earth
- C: Cold water inlet
- D1: Sectional valve
- E: Waste water drain Ø30 mini
- F: Steam exhaust, horizontal Ø180 mm outlet, towards the back of the oven
- G: Smoke outlet, Ø180 mm vertical
- H: Oil or gas

No flammable material within less than 16 cm from the 500°C smoke and 200°C steam exhausts.

3.2. GAS CONNECTION AND BURNER ADJUSTMENT

3.2.1 Checks

Connect the oven to the gas supply via a shut-off valve allowing the oven to be isolated from the rest of the installation.

The gas supply piping must be sized so as to reduce line pressure losses: its diameter must be specified as appropriate for its path (length, number of elbows ...) and total oven power. It terminates with a 26/34 female fitting.

Check that the oven adjustments are appropriate for the type of gas and distributed pressure throughout the installation.

To check the oven's gas supply pressure, connect a water column manometer to the pressure nozzle on the burner valve unit.

3.2.2 Installing the gas burner

Approved burner models for CRISTAL ovens are as follows:

NATURAL GAS (G20, 20 mbar or G25, 25 mbar)			
	RIELLO	ELCO	CUENOD
M1	40 FS 10	VG1.55	FC6 GX 107/8 AT1
M2	40 FS 10	VG1.85	FC9 GX 107/8 AT1

PROPANE (G31, 50 or 37 mbar)			
	RIELLO	ELCO	CUENOD
M1	40 FS 10 + propane kit	VG1.55	FC6 GX 107/8 AT1
M2	40 FS 10 + propane kit	VG1.85	FC9 GX 107/8 AT1

- Install the burner and the valve unit (as shown on the previous page).
- Check that the gas circuit is leak-tight using a gas leak detector.
- For RIELLO propane burners, replace the \varnothing 2.2 nozzle with the \varnothing 1.5 nozzle supplied for propane (see the manual enclosed).
- For CUENOD or ELCO propane burners, install the propane seal cap provided (see Burner manual).
- **When handling the burner, do not drop anything inside the furnace.**
- For any further information regarding the burner, refer to the manual that comes with it.

M1 RIELLO burner

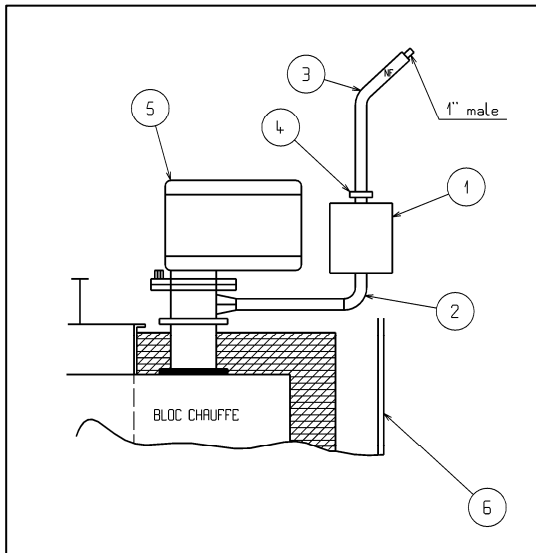

Side view

M2 RIELLO burner

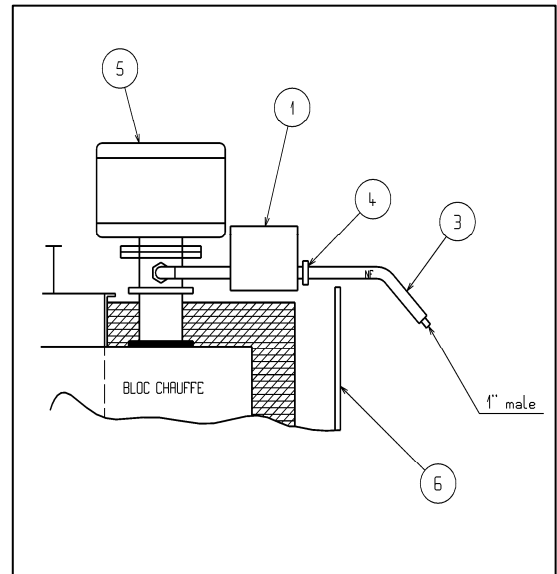

Side view

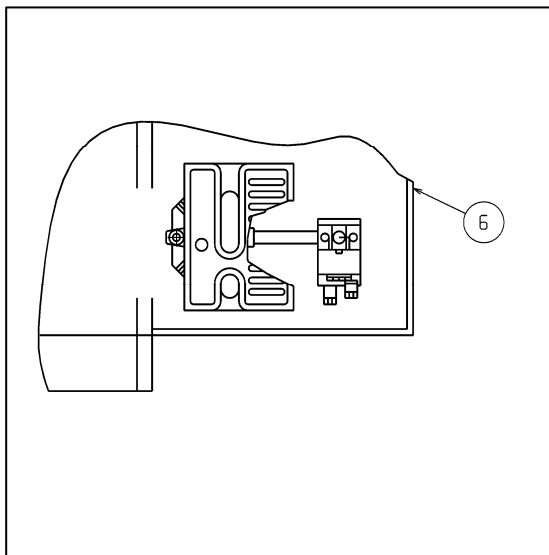

Top view

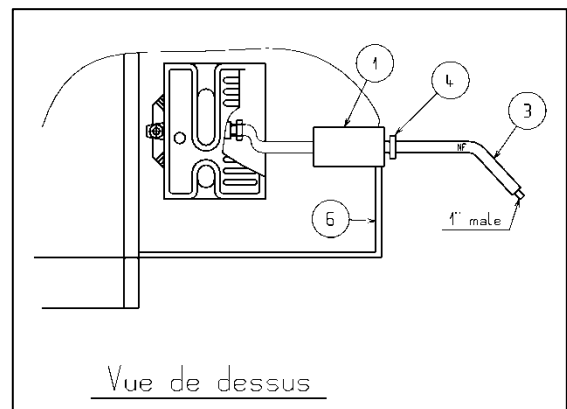

Top view

1. Valve unit
2. Normal elbow 20/27 MIF (31285)
3. NF hose 1 inch MMLG750
4. Reduction (31139)
5. Burner
6. Heating unit rear panel

**M1 and M2 CUENOD burners
M1 and M2 Elco burners**

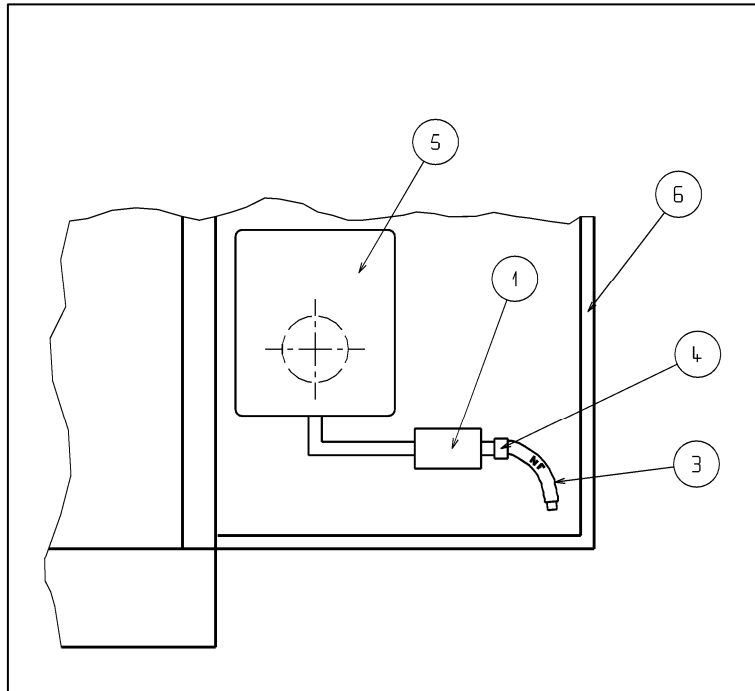

Top view

The burner must protrude 3cm inside the combustion chamber.

3.2.3 Adjustments

- Adjustment of the combustion head (see burner manual)
 - . RIELLO burner for M1 ovens: no. 0
 - . RIELLO burner for M2 ovens: no. 2
 - . ELCO burner for M1 ovens: dimension Y = 30
 - . ELCO burner for M2 ovens: dimension Y = 32
 - . CUENOD burner for M1 ovens: dimension Y = 30
 - . CUENOD burner for M2 ovens: dimension Y = 32
- Adjustment of electrodes (see burner manual).
- Check that the valve unit inlet pressure matches the specifications in the table below:

Natural gas Lacq Group H-G20	20 mbar
Natural gas Holland Group L-G25	25 mbar
Propane gas G31	50-37 mbar

- Adjustment of the gas flow, according to the table

Oven reference	Rated heat release (Kw sur HI)	Natural gas G20 - 20 mbar flow (L/min) at 15°C, 1013 mbar	Natural gas G25 - 25 mbar flow (L/min) at 15°C, 1013 mbar	Propane gas 50 - 37 - 30 mbar flow (L/min) at 15°C, 1013 mbar	Propane gas 50-37-30 mbar flow (g/min) at 15°C, 1013 mbar
M1	47	80	92	31	58
M2	77	136	158	53	99

- Adjustment of the air damper for efficient combustion (see burner manual)

	M1	M2
RIELLO	Rep. 2.5	Rep. 4
ELCO	Rep 14	Rep.12
CUENOD	Rep. 18	Rep.12

Figures indicated are for basic adjustments. They should be adapted in accordance with combustion test results.

- Adjustment of the air pressure switch: see manual

3.3. ELECTRICAL CONNECTIONS**3.3.1 Table of amperages**

Frequencies	Voltage	M1 Gas/Oil	M1 Electric	M2 Gas/Oil	M2 Electric
50Hz	220V	7 A	104 A	10A	164 A
	230V	7 A	109 A	10 A	172 A
	380V	4 A	60 A	6 A	94 A
	400V	4 A	63 A	6 A	99 A
	415V	4 A	65 A	6 A	103 A
60Hz	208V	10 A	101 A	14 A	157 A
	220V	10 A	106 A	14 A	166 A
	230V	10 A	112 A	14 A	175 A
	400	6 A	64 A	8 A	101 A
	415	6 A	67 A	8 A	104 A

3.3.2 Power ratings table

Frequencies	Voltage	M1 Gas/Oil	M1 Electric	M2 Gas/Oil	M2 Electric
50Hz	220V-380V	2.5 kW	39.5 kW	4 kW	62.5 kW
	230V-400V	2.5 kW	43.5 kW	4 kW	68.5 kW
	415V	2.5 kW	47 kW	4 kW	74 kW
60Hz	208V	3.5 kW	36.5 kW	5 kW	56.5 kW
	220V-380V	3.5 kW	40.5 kW	5 kW	63.5 kW
	230V-400V	3.5 kW	44.5 kW	5 kW	69.5 kW
	415	3.5 kW	48 kW	5 kW	75 kW

3.3.3 Electrical connections

	Oven type	M1		M2	
		Oil/Gas	Electric	Oil/Gas	Electric
Cables	208 to 240V	4 x 2.5 mm ²	4 x 35 mm ²	4 x 4mm ²	4 x 50 mm ²
	380 to 415V	5 x 1.5 mm ²	4 x 16 mm ²	5 x 2.5 mm ²	4 x 35 mm ²

- Cross sections are given for 1000RO2V cables for a maximum temperature of 30°C.

3.3.4 Connecting the fittings

CRISTAL M1-M2 OIL /GAS

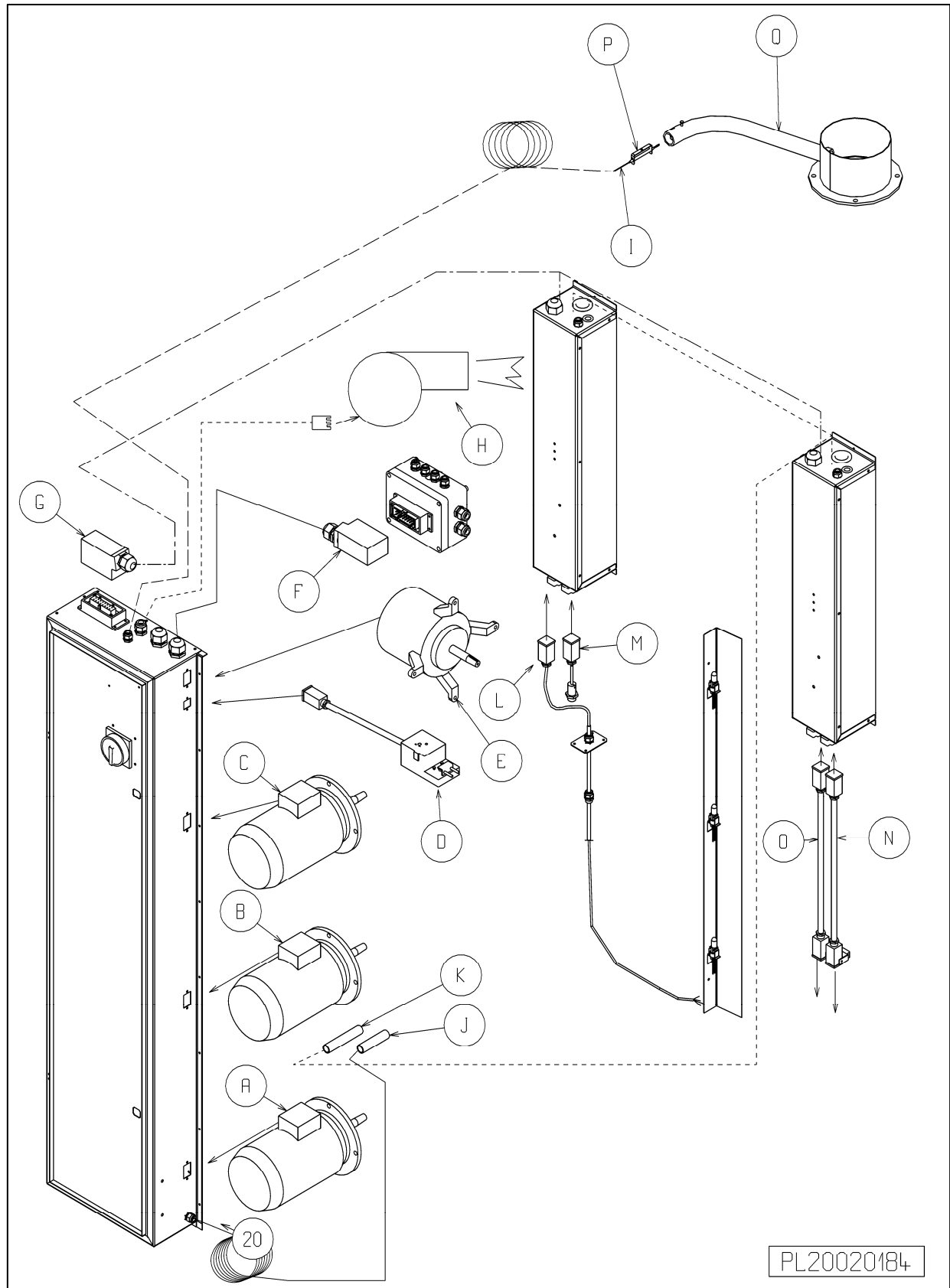

CRISTAL M1-M2 OIL/GAS

- A.** Moteur turbine de ventilation du bas
- B.** Moteur turbine de ventilation du milieu
- C.** Moteur turbine de ventilation du haut
- D.** Servomoteur de la commande du oura
- E.** Moteur de l'extracteur de buée
- F.** Connecteur 16 plots de la boîte de dérivation plafond
- G.** Connecteur 16 plots de la façade avant
- H.** Connecteur 6 plots du brûleur
- I.** Thermostat de sécurité des fumées
- J.** Doigt de gant du thermostat de sécurité de four
- K.** Doigt de gant du thermocouple de régulation du four
- L.** Connecteur 5 plots de l'éclairage
- M.** Connecteur 5 plots des détecteurs de la porte
- N.** Rallonge du détecteur de porte pour façade à gauche
- O.** Rallonge de l'éclairage pour façade à gauche
- P.** Support bulbe sécurité
- Q.** Tube sortie fumées

3.3.5 Connecting the fittings

CRISTAL M1-M2 ELECTRIC

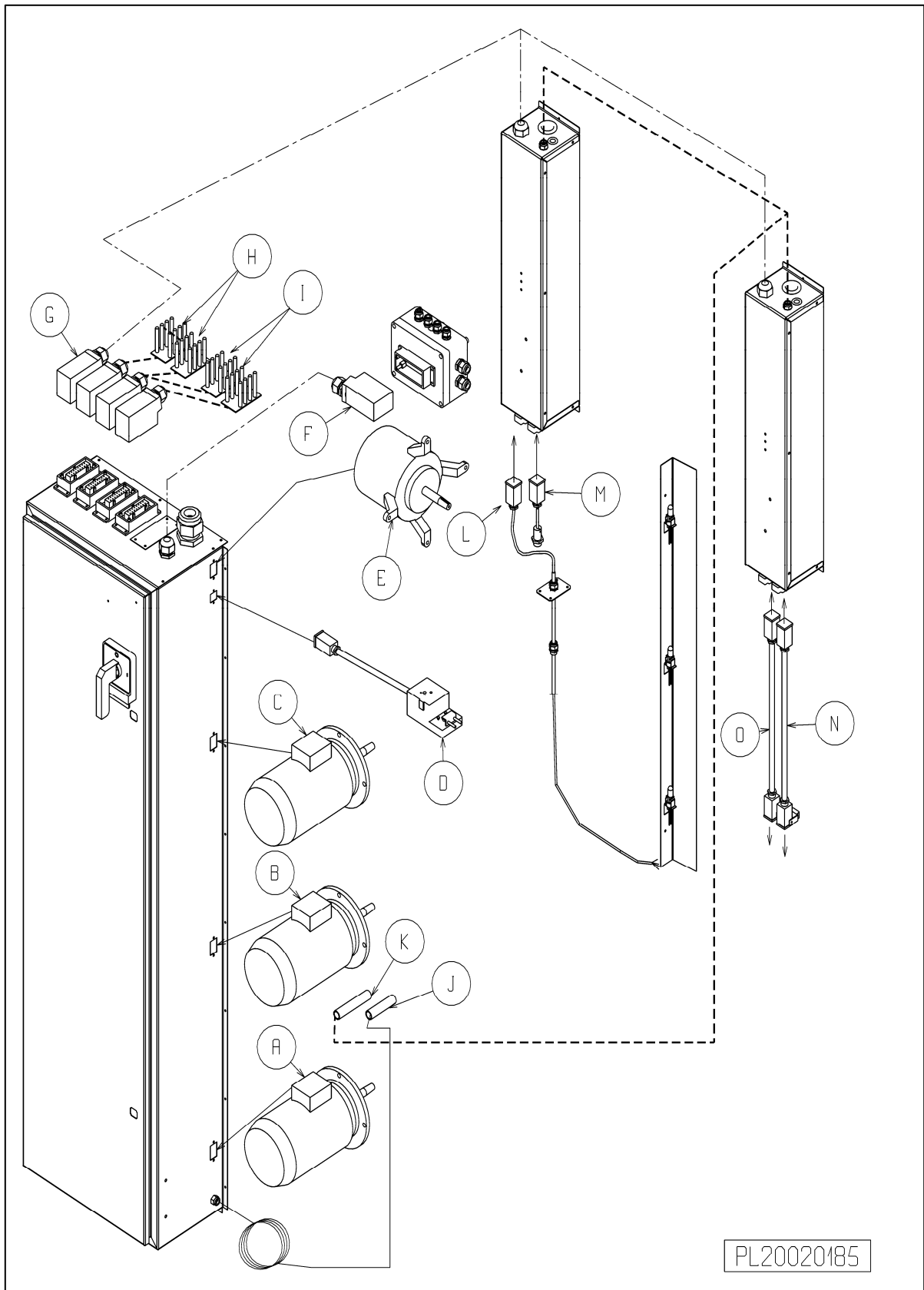

CRISTAL M1-M2 ELECTRIC

- A.** Moteur turbine de ventilation du bas
- B.** Moteur turbine de ventilation du milieu
- C.** Moteur turbine de ventilation du haut
- D.** Servomoteur de la commande du oura
- E.** Moteur de l'extracteur de buée
- F.** Connecteur 16 plots de la boîte de dérivation plafond
- G.** Connecteur 16 plots de la façade avant
- H.** Connecteur 6 plots du bloc résistance de gauche
- I.** Connecteur 6 plots du bloc résistance de droite
- J.** Doigt de gant du thermostat de sécurité de four
- K.** Doigt de gant du thermocouple de régulation de four
- L.** Connecteur 5 plots de l'éclairage
- M.** Connecteur 5 plots des détecteurs de la porte
- N.** Rallonge du détecteur de porte pour façade à gauche
- O.** Rallonge de l'éclairage pour façade à gauche

3.4. WATER CONNECTION

The room must have a water supply point with an inlet pressure between 1 and 5 bars max. and fitted with a shut-off valve. Connector diameter: copper 10/12 with 20/27 male fitting.

Also provide for a ground drain (water overflow) with a pipe having a diameter of 44 mm to the sewer system and a minimum slope of 1 cm per metre.



This equipment is not equipped with a protective device against the drinkable water pollution by return of water.

In Europe, it is of your responsibility for respecting the regulations in force and for setting up the protective device against the drinkable water pollution by return of water adapted to the configuration of your bakery and your network of the water supply, and in compliance with the standard IN 1717, in application of the European directive 98 / 83-CE.

3.5. SMOKE EXHAUST CONNECTION

Connection is done using a 150 mm diameter stainless steel pipe for M1 Ø 180 mm for M2.

The vertical smoke flue must have a diameter of 200 and be fitted with a closed steam trap.

3.6. STEAM EXHAUST CONNECTION

Ø 180 mm.

The vertical steam flue must have a diameter of 200 and be fitted with a bleeder for condensation discharge.

3.7. FRESH AIR INTAKE

The installation site must include fresh air inlets in accordance with current regulations.

- If the oven steam outlet is connected to the exterior, a fresh air inlet flow of 1000 m³/h for the oven is required.

- If the steam outlet is connected to a system discharging air inside the oven room (e.g. into a condenser), a fresh air inlet flow for the oven is required as follows:

90 m³/h for M1
140 m³/h for M2

3.8. OIL CONNECTION AND BURNER ADJUSTMENT

The connection should be done with a 10/12 copper pipe, as per the recommendations on the next page.

2 valves with check valves are required.

3.8.1 Installing the oil burner

Oil burners compatible with CRISTAL ovens are as follows:

	RIELLO	ELCO	CUENOD
M1	40 F10	VL1.55	FC6 H101 AT1
M2	40 F10	VL1.95	FC9 H101 AT1

– Install the nozzle with the burner (see settings table)

- When handling the burner, do not drop anything inside the furnace.
- For any further information regarding the burner, refer to the manual that comes with it.

3.8.2 Adjustments

- Adjustment of the combustion head (see burner manual)

	M1	M2
RIELLO	2.5	4
CUENOD	Y=20	Y=16
ELCO	Y = 20	Y=16

- Adjustment of electrodes (see manual)
- Adjust the oil flow by installing a pressure gauge on the pump (see burner manual). Adjust the pressure according to the table below.

	Nozzle (US gal)	Oil pressure bar	Oil flow l/hour
M1	1 gal, 60°	11	4.7
M2	1.65 gal, 60°	11	7.8

- Adjustment of the air damper for efficient combustion - see burner manual -

	M1	M2
RIELLO	3	6.5
CUENOD	18	14
ELCO	18	14

Figures indicated are for basic adjustments. They should be adapted in accordance with combustion test results.

- Adjustment of the air pressure switch -see burner manual-

RECOMMENDATIONS FOR RIELLO BURNERS

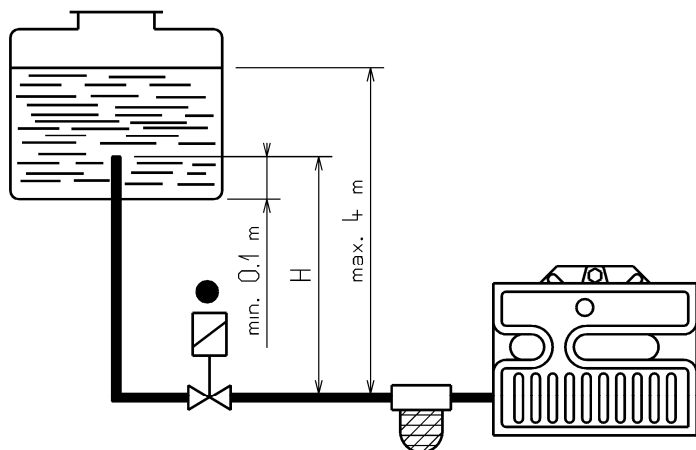

H = Difference in height
 L = Maximum length of suction pipe
 $\varnothing i$ = internal diameter of the pipe

T metre	L metres	
	$\varnothing i$ 8 mm	$\varnothing i$ 10 mm
0.5	10	20
1	20	40
1.5	40	80
2	60	100

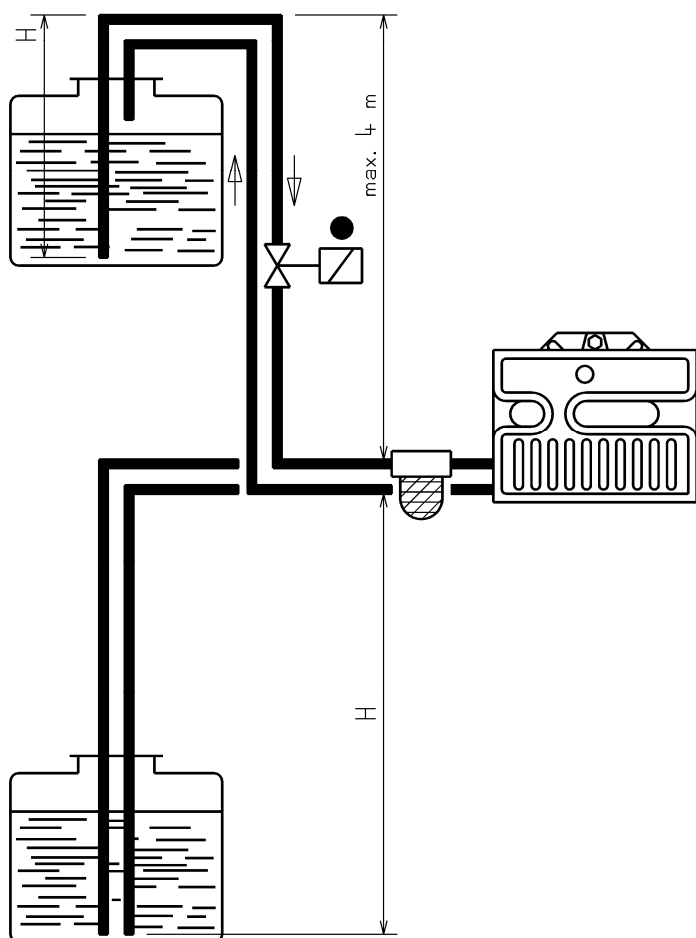

The oil lines must be perfectly leak-tight. It is advisable to design the arrival and return points at the same height in the tank. In this case the bottom valve is not required. If, on the other hand, the return line is located above the oil level, the bottom valve must be installed. This solution is less safe than in the previous case, owing to the possibility of valve leakage.

T metre	L metres	
	$\varnothing i$ 8 mm	$\varnothing i$ 10 mm
0	35	100
0.5	30	100
1	25	100
1.5	20	90
2	15	70
3	8	30
3.5	6	20

PL20020198

RECOMMENDATIONS for ELCO or CUENOD BURNERS

Pipe dimensions

SINGLE-PIPE SYSTEM PRESSURE SIDE

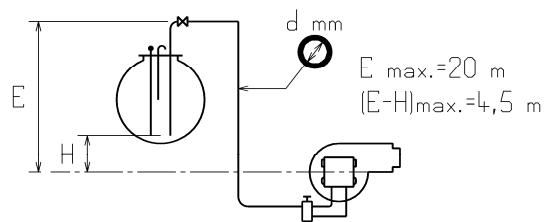

GPH NOZZLE	0.5	0.6	0.8	1	1.5	2
D(mm)	4	4	4	4	4	6
H(m)	4	4	4	4	4	6
0	90	75	56	45	30	150
0.5	100	83	63	50	33	150
1	110	92	69	55	37	150
2	131	109	82	65	44	150
3	152	126	95	76	50	150
4	172	144	108	86	57	150

SINGLE-PIPE SYSTEM SUCTION SIDE

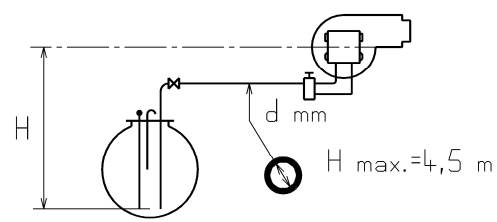

GPH NOZZLE	0.5	0.6	0.8	1	1.5	2
D(mm)	4	4	4	4	4	6
H(m)	4	4	4	4	4	6
0	90	75	56	45	30	150
0.5	76	66	50	40	26	134
1	69	57	43	34	23	116
2	48	40	30	24	16	80
3	28	23	17	14	9	47
4	7	6	4	0	0	12

TWIN-PIPE SYSTEM PRESSURE SIDE

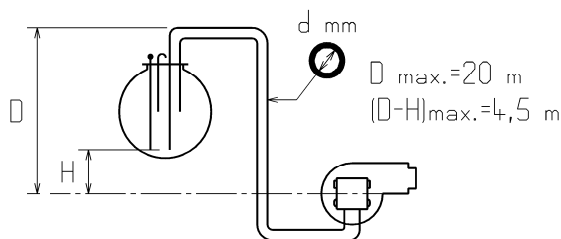

HEIGHT	PIPE OUTER DIAMETER d (mm)			
m	4	6	8	10
0	2	15	50	124
0.5	2	16	56	138
1	2	18	61	150
2	3	22	73	150
3	4	26	85	150
4	4	30	97	150

TWIN-PIPE SYSTEM SUCTION SIDE

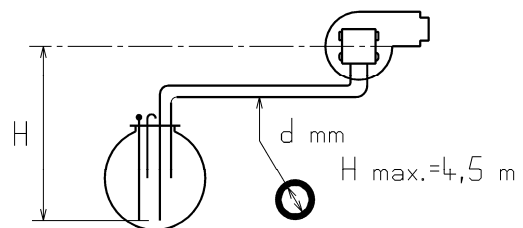

HEIGHT	PIPE OUTER DIAMETER d (mm)			
m	4	6	8	12
0	15	50	124	150
0.5	13	44	109	150
1	11	38	95	150
2	7	26	66	138
3	3	14	37	79
4	0	0	8	19

*** Single-pipe system suction side**

We thoroughly recommend the use of a prefilter linked to the pump by twin pipes - this allows for manual or automatic draining of the installation.

Open the drain cock during burner inhibition and only close when oil flows through the drain cock. The volume of residual air in the pump will be eliminated through the nozzle.

The pump is not amenable to conversion from a twin pipe to a single pipe configuration.

Maximum lengths (intersection of a line and a column) are indicated in metres and have been calculated with four elbows, 1 stop valve and 1 check valve. In the event of additional limitation, this length should be reduced by equivalent values as regards head loss.

Examples:

Twin pipe system suction side:

- Suction height: 1 metre
 - Length of pipes between the burner and the tank bottom: 25 metres
- Pipes with an internal diameter of 8 mm (6 mm is too small as max. length = 10 metres) should be used.

Single pipe system pressure side:

- Nozzle used: 2 gph
- Distance between tank bottom and burner: 0.5 metre
- Pipe length: 70 metres

Pipes with an internal diameter of 6 mm (4 mm is too small as max. length = 24 metres) should be used.

4. CONVERTING THE OVEN FOR USE WITH A DIFFERENT TYPE OF GAS



For Belgium, this operation has to be carried out by Pavailler.

For all other countries, this operation has to be carried out by a qualified technician.

4.1. RIELLO BURNER

Replace the current injector by a model compatible with the new type of gas.

. Natural gas \varnothing 2.2

. Propane gas \varnothing 1.5

Repeat complete burner adjustment procedure (*see section 3.2*).

4.2. CUENODOR ELCO BURNER

Install or remove the propane seal cap

. Natural gas → no seal cap, diffuser set.

. Propane gas → cap installed, diffuser removed.

Repeat complete burner adjustment procedure (*see section 3.2*).

Record the results in the maintenance log.

5. OPERATION AND INSTRUCTIONS FOR USE

5.1. CONTROL PANEL

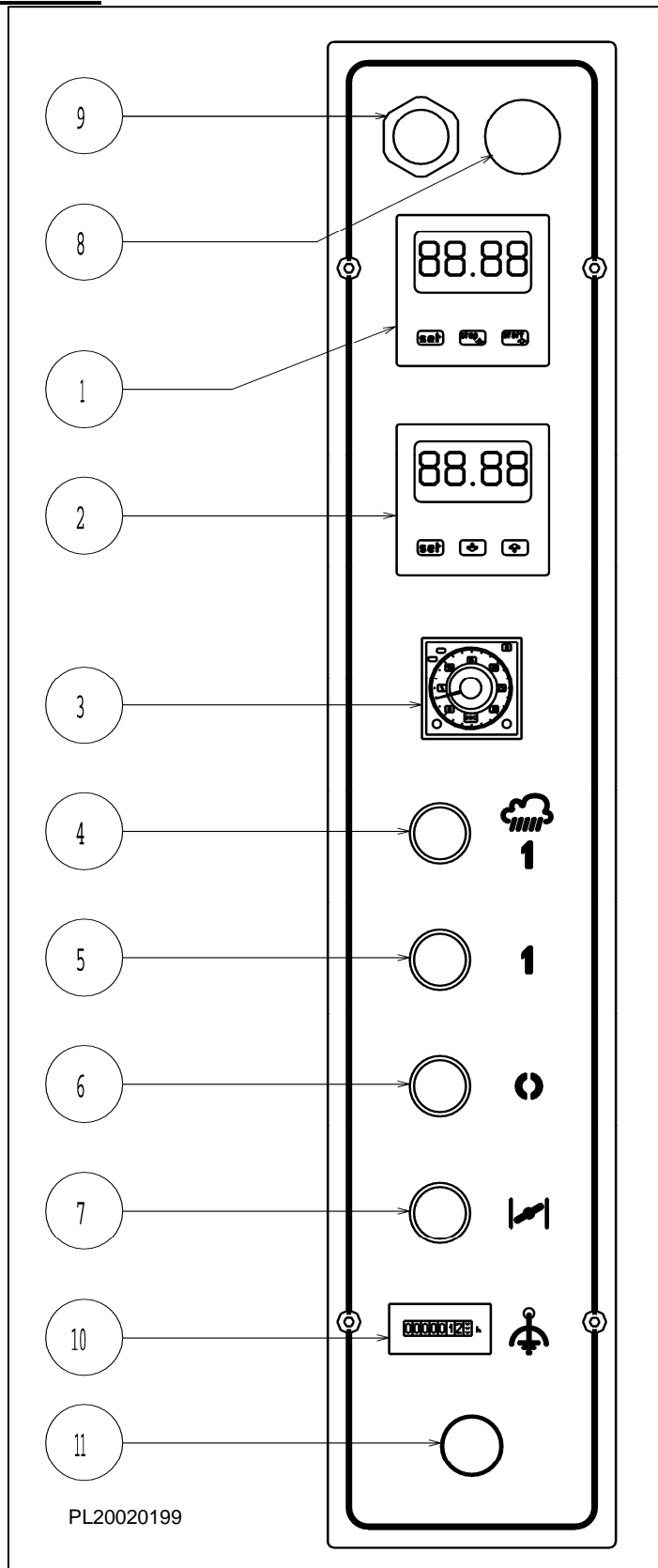

REP.	DESIGNATION	UTILISATION
1	Minuterie de fin de cuisson ou démarrage différé	Détermine la fin de cuisson par buzzer ou permet le démarrage du four en différé
2	Régulateur de température	Permet de régler la température de la chambre de cuisson
3	Minuterie de buée	Règle la durée d'injection de buée
4	Bouton marche avec buée	Permet le démarrage du four et l'injection automatique de buée
5	Bouton marche sans buée	Permet le démarrage du four sans injection de buée (préchauffage ou cuisson viennoiserie)
6	Bouton arrêt	Permet l'arrêt du four (sans extraction de buée)
7	Bouton d'ouverture du OURA	Permet le changement de position du OURA : Voyant éteint : OURA fermé Voyant éclairé : OURA ouvert
8	Voyant	Signal lumineux de fin de cuisson
9	Buzzer	Signal sonore discontinu en fin de cuisson Signal sonore continu pendant la descente du chariot
10	Compteur totalisateur	Indiquer le nombre d'heure de fonctionnement du four (pour entretien)
11	Bouchon	

The oven door opening (ajar position) allows for automatic steam discharge before opening the door completely (delayed safety system).

5.2. TIMER

This timer has two operational modes:

- baking timer from 00 to 99 minutes
- automatic oven start-up from 00 hr 00 min to 99 hr 59 minutes

To change over to automatic start-up mode, press 'Stop' for 3 seconds.

To return to baking timer mode, press 'Stop' once.

The display is different depending on the mode selected:

In baking timer mode, two digits are displayed.

In automatic start-up mode, four digits are displayed.

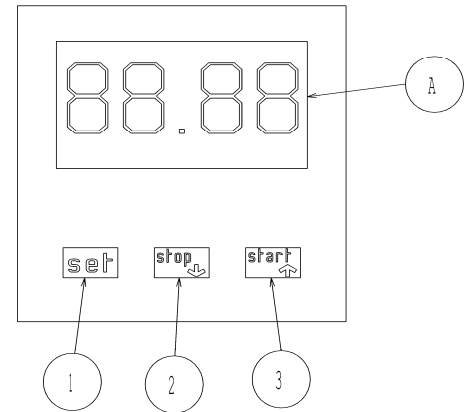

5.2.1 Baking timer mode

The baking timer mode makes it possible to indicate the end of the baking time by means of a buzzer (Note: the oven does not actually turn off automatically).

- To set the baking time, press 'Set': The display will flash. Reduce or increase the baking time using the 'Stop' or 'Start' buttons. Press 'Set' to confirm. The display will stop flashing.
- To start the timer running, press 'Start'.
- During the baking time, you can use the 'Stop' button to stop and go back to the programmed baking time.
- At the end of the baking time, press 'Stop' to silence the buzzer.

5.2.2 Automatic start-up mode

The automatic start-up mode makes it possible to start the oven automatically once the programmed time has elapsed (for pre-heating).

- To set the time before start-up: press 'Set'. The hours flash. Reduce or increase the value using the 'Stop' or 'Start' buttons. Press 'Set'. The minutes will now flash. Adjust the value using the 'Stop' or 'Start' buttons.
- To start the countdown, press 'Start'. The colon will flash.
- You can stop the countdown by pressing the 'Stop' button and return to baking timer mode.
- At the end of the countdown, the oven starts and the timer reverts to baking timer mode.

5.3. TEMPERATURE REGULATOR

This is where you can select the baking temperature. The temperature value is shown on the regulator display. As soon as the temperature setpoint is reached, the display OUT1 goes out.

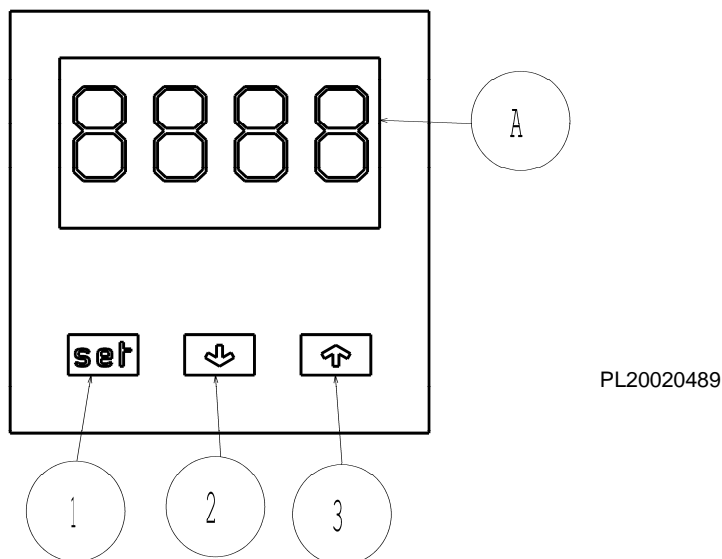

5.3.1 Oven temperature reading

Permanently shown on the display (A).

5.3.2 Reading and changing the temperature

Press the SET button (1) once.

The bottom left thermometer icon will flash. The temperature value is displayed.

You can adjust this temperature using the up (3) and down (2) arrows.

To go back to the actual oven temperature, press SET once. The thermometer icon will go out.

5.3.3 Locking the regulator

Continue pressing the up arrow button (3) (for approx. 4 sec) until the device displays '0-nn'.

The regulator is now locked. If you press 'set', '0-nn' is displayed and you can no longer see or change the set temperature.

To unlock, continue pressing the up arrow (around 4 sec) until 0-nn disappears.

5.4. START-UP

CAUTION ON THE RISKS OF BURNS :

During all the duration of use of the oven in cooking, from the preheating to the cooling, there are residual risks of burns, particularly at the front of the oven, especially on articulated windows.

Wearings personal protective equipment like anti-scald gloves is **REQUIRED** for the introduction and the withdrawal of cooking support in the oven.

PRELIMINARY OPERATIONS:

- CHECK the direction of rotation of impellers (anti-clockwise inside the oven) by pressing an impeller motor contactor KM6.

If necessary, reverse 2 phases on the MAINS SUPPLY of the disconnection switch.

- Then press the contactor KM4 briefly to check that you are in the UP DIRECTION.

THEN:

Set the switch to the ON position on the oven's electrical cabinet.

- Position 0 - oven OFF

- Position 1 - oven ON

Close the oven door.

Set the timer to 'bake' mode.

Set the temperature regulator to the required temperature.

Press the ON button 1, the indicator lights up (steam generator off)

The oven is pre-heating.

Heat-up time

Oven 15'

Steam heat-up time: 1 hour

Automatic start-up

See baking timer.

5.5. BAKING TIME

- The values are given by way of information. The user should adjust these as preferred.
- Temperature between 220° and 230°C.

Products:	200 gr	20'
	250 gr	25'
	400 gr	30'
	500 gr	35'

5.6. STARTING A BAKING CYCLE

The oven is ON (press 'Start'):

- Set the steam generator timer,
- Set the baking time on the timer.

To load the 1st rack, stop the oven by pressing the OFF button 0.

- Open the door.
- Insert the rack.
- Close the door.
- Press the 'Start with steam' button.
- The oven starts with automatic steam injection.
The impeller and burner do not start immediately (approx. 2' time delay).

5.7. END OF BAKING CYCLE

- Open the DAMPER where applicable.
- Open the door with the handle and leave it ajar.
.The steam exhaust fan starts
.At the end of the extraction process, the rack descends and the door is unlocked.
- Remove the rack.

5.8. CLEANING OF THE OVEN

Regularly clean the oven inside and outside surfaces to prevent excess dirt.
Before any cleaning operation switch off the oven and disconnect it.

Prevention of risks related to flour emissions:

Cleaning may raise substantial amounts of flour dust. Flour dust is the main cause of respiratory allergies in bakery.

- Do not use compressed air blowers.
- Use a suitable industrial vacuum cleaner.

5.8.1 Cleaning of stainless steel surfaces, painted parts and glazing:

Use:

- detergents such as soap, lye, dishwashing products, bleach-free window-cleaning products. Always rinse off with clear water.
- sponges, clean cloths and chamois leather, squeegees.

Do not use:

- any products containing bleach or other chlorinated derivatives
- pressurized water jets or high pressure cleaners.
- brush with steel bristles or steel pads
- silverware cleaning products
- powders for scouring and scraper sponges
- hydrochloric acid is strictly forbidden.

Clean: interior, middle and exterior door glazing.

- Remove the external knurled nuts and silicone washers (4 each) and clean the exterior and middle glazing.
- Assemble in reverse order and tighten the knurled nuts manually.
- Then remove the knurled nuts and silicone washers (10 each) of the interior glazing and clean the interior and middle glazing.
- Assemble in reverse order and tighten the knurled nuts manually. Make sure you replace the gasket of the interior glazing properly.

Remove any dust from the oven.

5.8.2 Cleaning of the floor around the oven

Make sure not to let any water underneath the oven when cleaning the floor.

No bleach (even diluted) should go underneath the oven.

Avoid any contact with acids especially hydrochloric acid. (Used by floor tilers for cleaning purposes)













5.9. ELECTRONIC CONTROL PANEL

5.9.1 Presentation













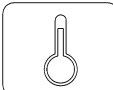

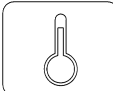
Nos.	Description
1	Oven start-up
2	Hood fan On/Off key
3	Steam injection
4	Temperature settings
5	Timer settings
6	Program selection
7	Opening of the steam damper with its indicator (indicator on = steam damper open; indicator off = steam damper closed)
8	Cycle start
9	"Minus" key
10	"Plus" key
11	Lighting On/Off key
12	Access to the "manual" mode
13	Current program
14	Baking time left (or programming)
15	Baking temperature (or programming)

5.9.2 Date settings

STEPS	DISPLAY	KEYS	ACTION										
0	<table border="1"> <tr><td>2</td><td>5</td><td>0</td></tr> <tr><td>1</td><td>1</td><td>2</td><td>2</td></tr> <tr><td>P</td><td>0</td><td>1</td></tr> </table>	2	5	0	1	1	2	2	P	0	1	PREHEATING MODE	→ Oven temperature: 250° → Time: 11h22 → Program: 01
2	5	0											
1	1	2	2										
P	0	1											
			Press 5 s										
1	<table border="1"> <tr><td></td><td></td><td></td></tr> <tr><td>0</td><td>9</td><td>3</td><td>2</td></tr> <tr><td></td><td></td><td></td></tr> </table>				0	9	3	2				 	TIME modification
0	9	3	2										
			Validation										
2	<table border="1"> <tr><td></td><td>1</td><td>1</td></tr> <tr><td>0</td><td>-</td><td>9</td><td>9</td></tr> <tr><td></td><td></td><td></td></tr> </table>		1	1	0	-	9	9				 	YEAR modification
	1	1											
0	-	9	9										
			Validation										
3	<table border="1"> <tr><td></td><td>0</td><td>4</td></tr> <tr><td>0</td><td>-</td><td>1</td><td>2</td></tr> <tr><td></td><td></td><td></td></tr> </table>		0	4	0	-	1	2				 	MONTH modification
	0	4											
0	-	1	2										
			Validation										
4	<table border="1"> <tr><td></td><td>1</td><td>2</td></tr> <tr><td>0</td><td>-</td><td>3</td><td>1</td></tr> <tr><td></td><td></td><td></td></tr> </table>		1	2	0	-	3	1				 	DAY modification
	1	2											
0	-	3	1										
			Validation Press 5 s or wait 10 s										



5.9.3 Delayed start (manual or automatic)

STEPS	DISPLAY	KEYS	ACTION												
0	<table border="1"> <tr><td>-</td><td>1</td><td>-</td><td></td></tr> <tr><td>1</td><td>8</td><td>2</td><td>0</td></tr> <tr><td></td><td></td><td></td><td></td></tr> </table>	-	1	-		1	8	2	0					STANDBY MODE	→ Day: Monday → Time: 18H20
-	1	-													
1	8	2	0												
			Press 5 s												
1	<table border="1"> <tr><td>-</td><td>-</td><td>-</td><td></td></tr> <tr><td>-</td><td>-</td><td>-</td><td>-</td></tr> <tr><td>H</td><td>0</td><td>1</td><td></td></tr> </table>	-	-	-		-	-	-	-	H	0	1		 	Timer selection (H01 to H14)
-	-	-													
-	-	-	-												
H	0	1													
			Press 5 s												
2	<table border="1"> <tr><td>-</td><td>2</td><td>-</td><td></td></tr> <tr><td></td><td></td><td></td><td></td></tr> <tr><td>H</td><td>0</td><td>1</td><td></td></tr> </table>	-	2	-						H	0	1		 	Timer selection
-	2	-													
H	0	1													
	<p>1 = Monday 2 = Tuesday 3 = Wednesday 4 = Thursday 5 = Friday 6 = Saturday 7 = Sunday</p>		<p>1-5 = From Monday to Friday 1-6 = From Monday to Saturday 1-7 = From Monday to Sunday 6-7 = From Saturday to Sunday</p>												
			Timer selection												
3	<table border="1"> <tr><td>P</td><td>0</td><td>1</td><td></td></tr> <tr><td></td><td></td><td></td><td></td></tr> <tr><td>H</td><td>0</td><td>1</td><td></td></tr> </table>	P	0	1						H	0	1		 	Press 5 s
P	0	1													
H	0	1													
			Timer selection												
4	<table border="1"> <tr><td>-</td><td>2</td><td>-</td><td></td></tr> <tr><td>0</td><td>6</td><td>0</td><td>0</td></tr> <tr><td>H</td><td>0</td><td>1</td><td></td></tr> </table>	-	2	-		0	6	0	0	H	0	1		 	Press 5 s
-	2	-													
0	6	0	0												
H	0	1													
		 OR 	Timer selection												





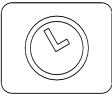

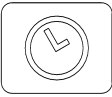



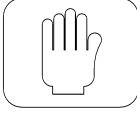

<p>If active timer</p>	<p>- 1 - 1 8 2 0 - - - - 2 - 0 6 0 0 H 0 1</p>	<p>Current status (Day and time)</p> <p>Programming (Day, time and program)</p>	<p>} Display in intermittence</p>	<p>Automatic start-up mode</p>
<p>If no active timer</p>	<p>- 1 - 1 8 2 0 - - -</p>			<p>Standby mode</p>

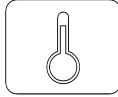
When the oven stops the next start-up is searched according to the day and time of the programmed timers. A maximum number of 14 timers can be programmed.

5.9.4 Operating hours counter







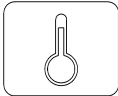

STEPS	DISPLAY	KEYS	ACTION
0	<p>- 1 - 1 8 2 0 - - -</p>	<p>STANDBY MODE</p>	<p>→ Day: Monday → Time: 18H20</p>
1	<p>- - - 1 2 7 H C 0 1</p>	  	<p>Counter selection: C01 = Number of operating hours of the board (power on) C02 = Number of running hours (except standby) C03 = Number of heating hours C03 = Number of non-heating hours C05 = Number of cycles initiated (button 8) C06 = Number of steam cycles (button 3)</p>
2			<p>Visual display output Press 5 s or wait 10 s</p>

5.9.5 Manual operation (without program)

STEPS	DISPLAY	KEYS	ACTION												
															
1	<table border="1" style="border-collapse: collapse; text-align: center;"> <tr><td>1</td><td>9</td><td>0</td><td></td></tr> <tr><td>0</td><td>0</td><td>1</td><td>5</td></tr> <tr><td>M</td><td>A</td><td>n</td><td></td></tr> </table>	1	9	0		0	0	1	5	M	A	n		 then  	Manual program selection MAn
1	9	0													
0	0	1	5												
M	A	n													
			Validation												
2	<table border="1" style="border-collapse: collapse; text-align: center;"> <tr><td>1</td><td>9</td><td>0</td><td></td></tr> <tr><td>0</td><td>0</td><td>1</td><td>5</td></tr> <tr><td>M</td><td>A</td><td>n</td><td></td></tr> </table>	1	9	0		0	0	1	5	M	A	n		 	Temperature modification
1	9	0													
0	0	1	5												
M	A	n													
			Validation												
3	<table border="1" style="border-collapse: collapse; text-align: center;"> <tr><td>1</td><td>9</td><td>0</td><td></td></tr> <tr><td>0</td><td>0</td><td>1</td><td>5</td></tr> <tr><td>M</td><td>A</td><td>n</td><td></td></tr> </table>	1	9	0		0	0	1	5	M	A	n		 	Baking time modification
1	9	0													
0	0	1	5												
M	A	n													
			Validation												
4	<table border="1" style="border-collapse: collapse; text-align: center;"> <tr><td>1</td><td>9</td><td>0</td><td></td></tr> <tr><td></td><td></td><td></td><td>0</td></tr> <tr><td>M</td><td>A</td><td>n</td><td></td></tr> </table>	1	9	0					0	M	A	n			End
1	9	0													
			0												
M	A	n													





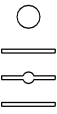
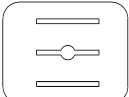









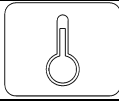

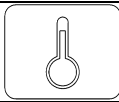

There is no automatic steam injection.

5.9.6 Manual modification during a baking cycle

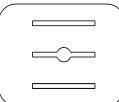
STEPS	DISPLAY	KEYS	ACTION									
												
1	<table border="1" style="border-collapse: collapse; text-align: center;"> <tr><td>2</td><td>0</td><td>0</td></tr> <tr><td></td><td></td><td>t 2</td></tr> <tr><td>P</td><td>0</td><td>1</td></tr> </table>	2	0	0			t 2	P	0	1	 	Temperature modification T1 = Preheating Temperature T2 = Baking Temperature
2	0	0										
		t 2										
P	0	1										
			Validation after 10 s									
			Validation									
2	<table border="1" style="border-collapse: collapse; text-align: center;"> <tr><td>2</td><td>0</td><td>0</td></tr> <tr><td>0</td><td>0</td><td>0 7</td></tr> <tr><td>P</td><td>0</td><td>1</td></tr> </table>	2	0	0	0	0	0 7	P	0	1	 	Modification of the baking time left
2	0	0										
0	0	0 7										
P	0	1										
			Validation after 10 s									
3			Holding the key: Steam injection									
4			Opening / closing of valve									
	LED on = Valve open LED off = Valve closed											



These settings are limited and do not change the programming of a recipe.

5.9.7 Recipe programming







STEPS	DISPLAY	KEYS	ACTION																				
		 then 	A red point flashes above on the right of P during all the programming																				
1	<table border="1" style="border-collapse: collapse; text-align: center;"> <tr><td>2</td><td>0</td><td>0</td><td></td></tr> <tr><td>0</td><td>0</td><td>2</td><td>0</td></tr> <tr><td>P</td><td>0</td><td>5</td><td></td></tr> </table>	2	0	0		0	0	2	0	P	0	5		 	Program selection								
2	0	0																					
0	0	2	0																				
P	0	5																					
			Validation																				
2	<table border="1" style="border-collapse: collapse; text-align: center;"> <tr><td>2</td><td>2</td><td>0</td><td></td></tr> <tr><td></td><td></td><td>t</td><td>1</td></tr> <tr><td>P</td><td>0</td><td>5</td><td></td></tr> </table>	2	2	0				t	1	P	0	5		 	Preheating temperature modification								
2	2	0																					
		t	1																				
P	0	5																					
			Validation																				
3	<table border="1" style="border-collapse: collapse; text-align: center;"> <tr><td>2</td><td>0</td><td>0</td><td></td></tr> <tr><td></td><td></td><td>t</td><td>2</td></tr> <tr><td>P</td><td>0</td><td>5</td><td></td></tr> </table>	2	0	0				t	2	P	0	5		 	Baking temperature modification								
2	0	0																					
		t	2																				
P	0	5																					
			Validation																				
4	<table border="1" style="border-collapse: collapse; text-align: center;"> <tr><td>2</td><td>0</td><td>0</td><td></td></tr> <tr><td>0</td><td>0</td><td>2</td><td>1</td></tr> <tr><td>P</td><td>0</td><td>5</td><td></td></tr> </table>	2	0	0		0	0	2	1	P	0	5		 	Baking time selection								
2	0	0																					
0	0	2	1																				
P	0	5																					
			Validation																				
5	<table border="1" style="border-collapse: collapse; text-align: center;"> <tr><td>○</td><td></td><td></td><td></td></tr> <tr><td>—</td><td></td><td></td><td>5</td></tr> <tr><td>—</td><td></td><td></td><td></td></tr> <tr><td>—</td><td></td><td></td><td></td></tr> <tr><td>P</td><td>0</td><td>5</td><td></td></tr> </table>	○				—			5	—				—				P	0	5		 	Valve opening time selection (at end of baking cycle)
○																							
—			5																				
—																							
—																							
P	0	5																					
			Validation																				
	<table border="1" style="border-collapse: collapse; text-align: center;"> <tr><td></td><td></td><td></td><td></td></tr> <tr><td></td><td></td><td>1</td><td>0</td></tr> <tr><td>P</td><td>0</td><td>5</td><td></td></tr> </table>							1	0	P	0	5		 	Steam injection time selection								
		1	0																				
P	0	5																					
6			Press 5 s: Parameter validation																				





Each key validates the previously modified parameter.

5.9.8 Selecting and starting a recipe

STEPS	DISPLAY	KEYS	ACTION										
0	<table border="1"> <tr><td>2</td><td>5</td><td>0</td></tr> <tr><td>1</td><td>1</td><td>2</td><td>2</td></tr> <tr><td>P</td><td>0</td><td>1</td></tr> </table>	2	5	0	1	1	2	2	P	0	1	PREHEATING MODE	→ Oven temperature: 250° → Time: 11h22 → Program: 01
2	5	0											
1	1	2	2										
P	0	1											
1			Program selection (see recipe programming)										
		Validation after 10 s											
	<table border="1"> <tr><td>2</td><td>5</td><td>0</td></tr> <tr><td>1</td><td>1</td><td>2</td><td>2</td></tr> <tr><td>-</td><td>-</td><td>=</td></tr> </table> <p>Intermittent sound signal</p>	2	5	0	1	1	2	2	-	-	=		Temperature reached End of preheating cycle
2	5	0											
1	1	2	2										
-	-	=											
			Door opening: Loading										
			Door closing										
2			Start of baking cycle										
	<table border="1"> <tr><td>2</td><td>5</td><td>0</td></tr> <tr><td>0</td><td>0</td><td>2</td><td>0</td></tr> <tr><td>P</td><td>0</td><td>1</td></tr> </table>	2	5	0	0	0	2	0	P	0	1		Baking cycle → Oven temperature: 250° → Time left: 20 min → Program: 01
2	5	0											
0	0	2	0										
P	0	1											
	<table border="1"> <tr><td>2</td><td>0</td><td>0</td></tr> <tr><td>0</td><td>0</td><td>2</td><td>0</td></tr> <tr><td>=</td><td>-</td><td>-</td></tr> </table> <p>Intermittent sound signal</p>	2	0	0	0	0	2	0	=	-	-		End of baking cycle
2	0	0											
0	0	2	0										
=	-	-											
3			Stop buzzer										

5.9.9 Protouch panel error list

ERROR	CAUSE	ACTION
Err 1	Defect if absence Sector > 2mn	Press key 
Err 2	Defect sounds Temperature 1 Detected if disconnected or defective probe (borders 29 and 30)	Press key 
Err 3	Defect sounds Temperature 2 Detected if disconnected or defective probe (borders 27 and 28)	Press key 
Err 4	Defect sounds Temperature 3 Detected if disconnected or defective probe (borders 25 and 26)	Press key 
Err 6	Defect of rack rotation(border 5)	Press key 
Err 7	Defect thermostats of security (border 6)	Press key 

ERREUR	CAUSE	ACTION
Err 11	Defect open door (border 4)	Press key 
Err 12	Defect battery : change the battery CR2032 if tension < 2,5V	Press key 
Err 13	Not exploitation of the oven Detected if the oven is in regulation since 45 mn or no injection vapor since 70 mn	Press key 
tEC 14	Annual revision if counter > 10000 h	Press key 
Err 16	Defect connection keyboard	Press key 

6. MAINTENANCE

Important:

**Maintenance and servicing must be carried out by a qualified technician.
The oven must be switched off (position 0 on the oven disconnection switch).
Never use the disconnection switch while the oven is on.**

6.1.1 Replacement of wear and adjustment parts.

- Replacement and tensioning of the screw-nut system belt (for M1 and M2 ovens only).

Adjustment and greasing of rack drive gears with WOLFRAKOT GREASE (grey).

- Greasing of the rack raising screw-nut system with WOLFRAKOT GREASE (grey) (only applicable for M1 and M2 versions).

- Greasing of the top ball thrust bearing, yoke and rotary shaft mount bronze rings, drive disc threading with HT BARRIERTA or PYRATEX GREASE (white).

- Greasing of the two ball bearings of the screw-nut system with BEARING GREASE (yellow) (for M1 and M2 ovens only).

IMPORTANT: never mix different greases together.

6.1.2 Oil or gas ovens

- Maintenance of burner max. every 6 months or 800 hours of operation. (Refer to burner manual).

- Clean the oil pump filter and replace the seal (oil ovens).

- Clean the oil prefilter (optional) (oil ovens).

- Sweep the flue in accordance with current local regulations.

In all cases, it must be swept at least once a year.

Check the door gasket and replace if necessary.

6.1.3 Steam generator

To be carried out max. every 6 months or after 800 hours of operation or as soon as steam injection efficiency is reduced.

- Remove the steam generators.
- Descale them
- Rinse thoroughly to eliminate any traces of the scale remover.
- Replace the steam generators.

7. WIRING DIAGRAMS

7.1. OIL/GAS 380/415V POWER DISTRIBUTION DIAGRAM

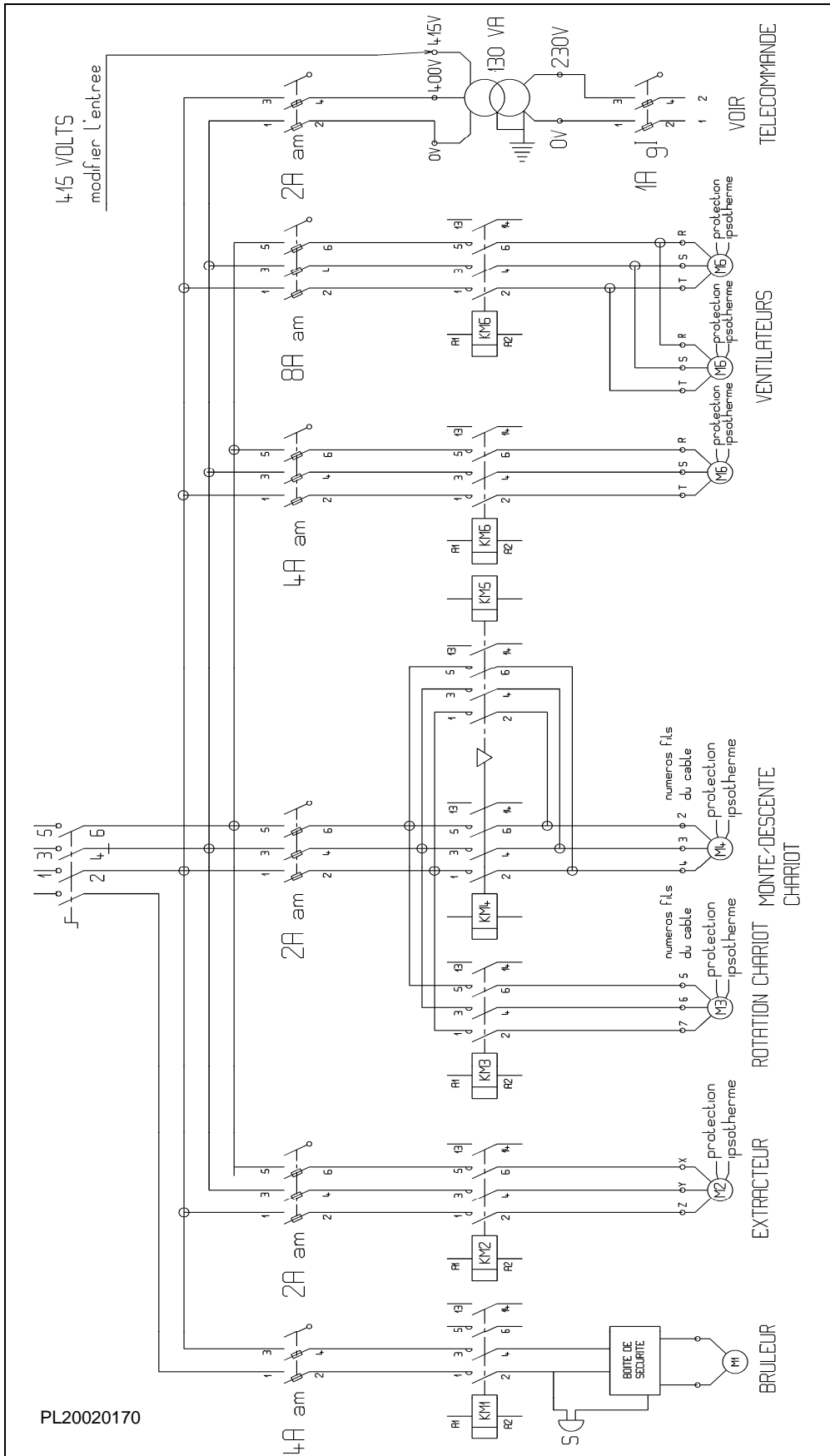

7.2. OIL/GAS 208/230 POWER DISTRIBUTION DIAGRAM

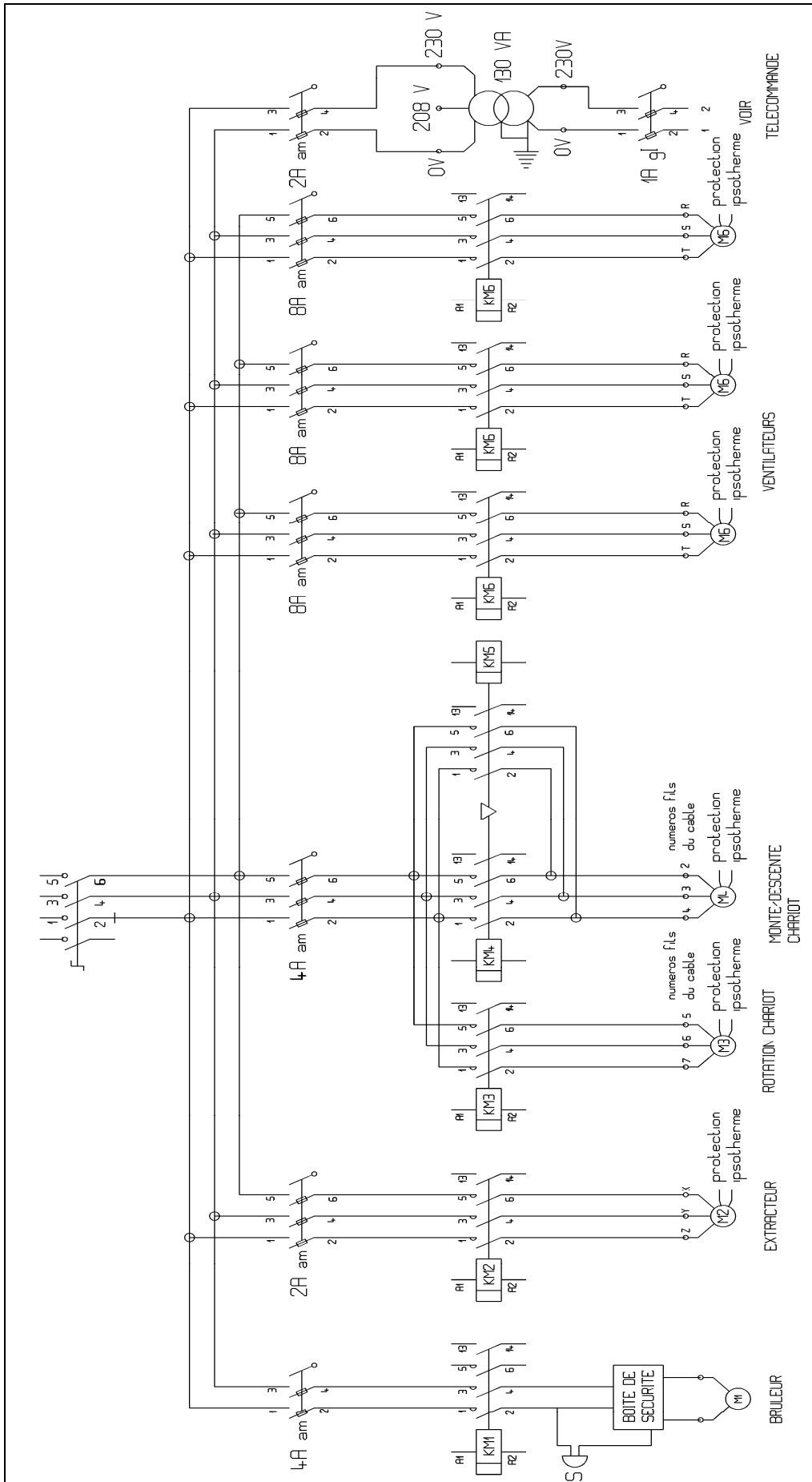

7.3. **ELECTRIC 380/415V POWER DISTRIBUTION DIAGRAM**

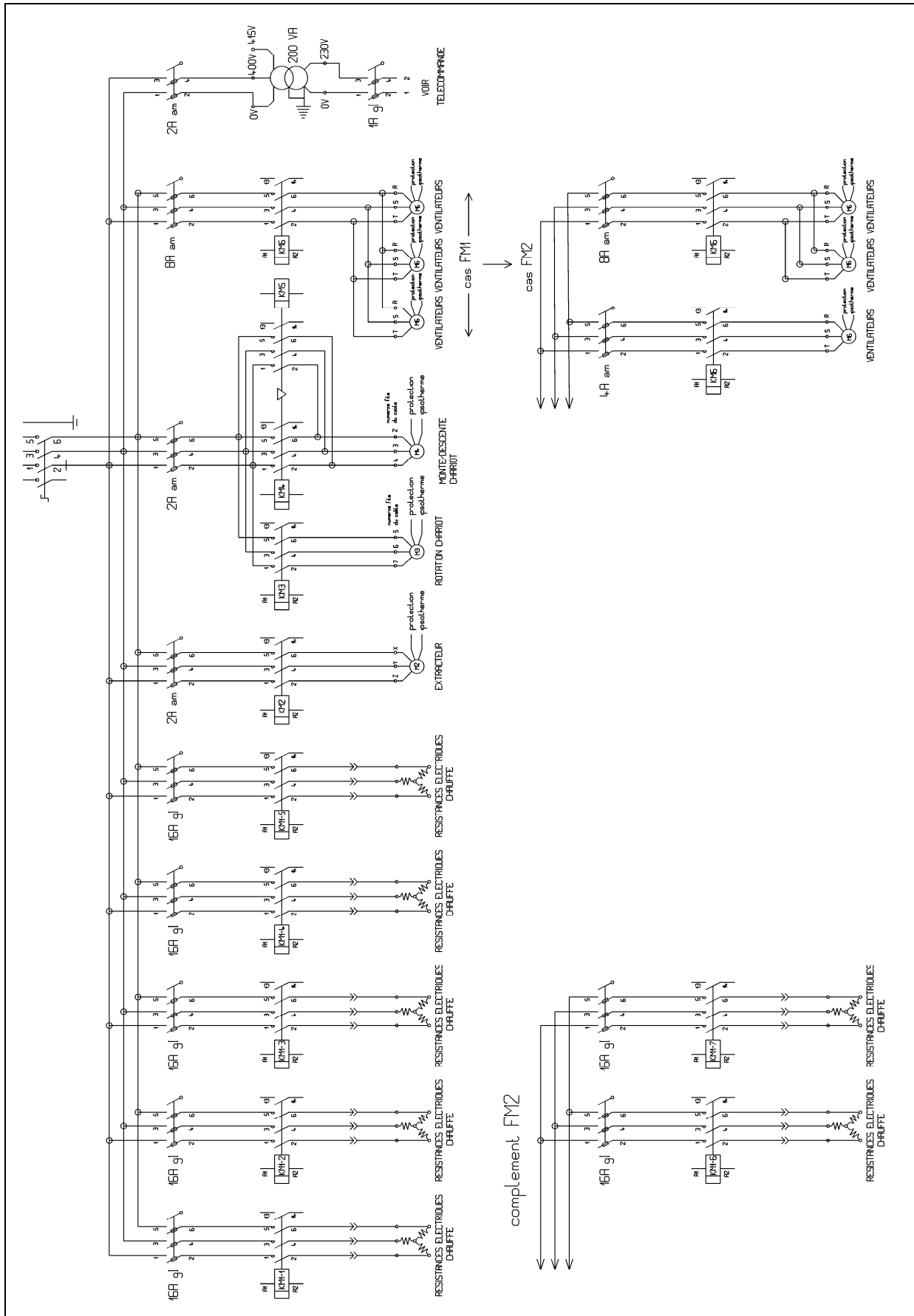

7.4. ELECTRIC 208/230V POWER DISTRIBUTION DIAGRAM

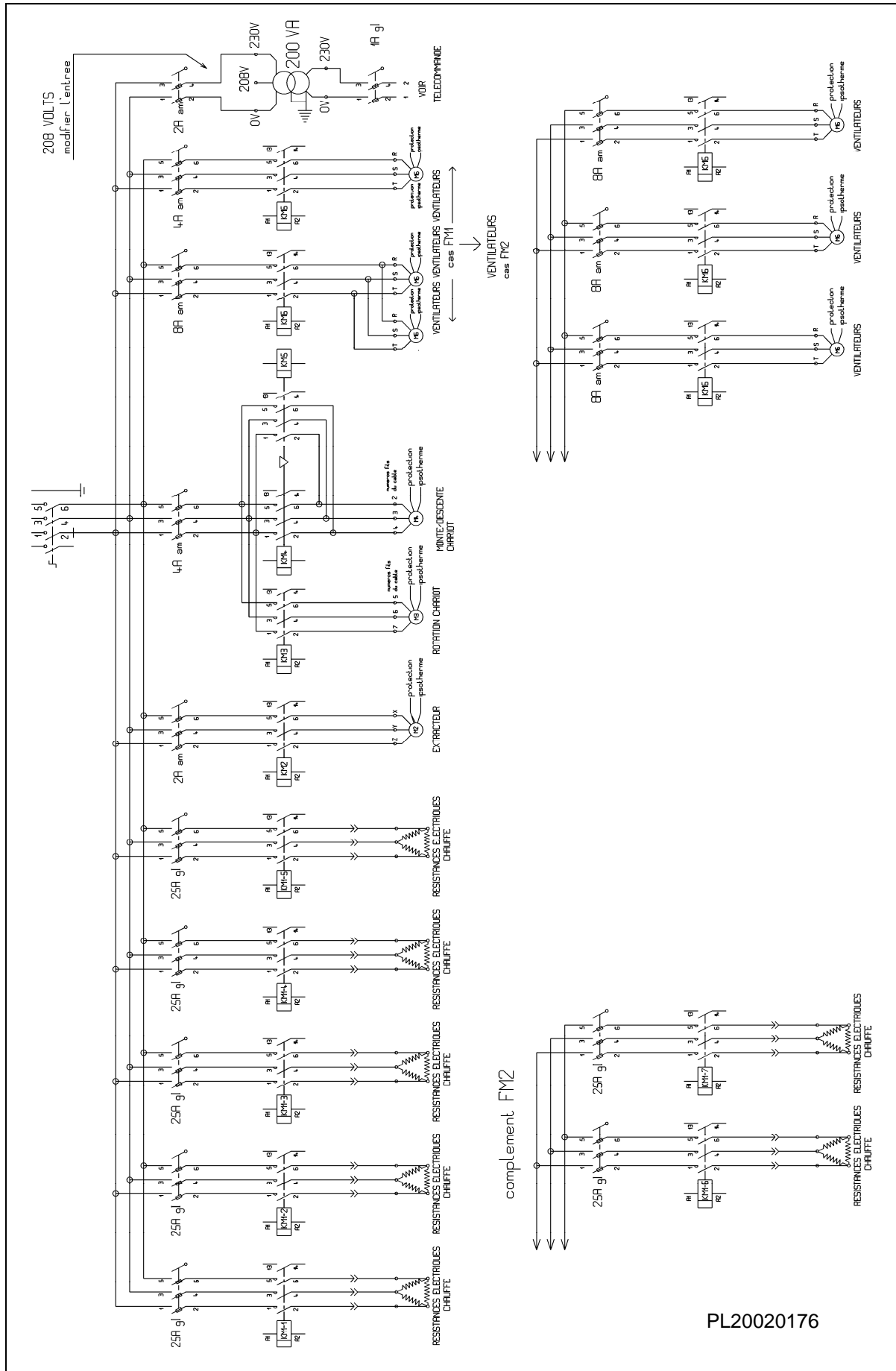

7.5. OIL/GAS FM1/2 POWER DISTRIBUTION DIAGRAM WITH SPEED VARIATOR

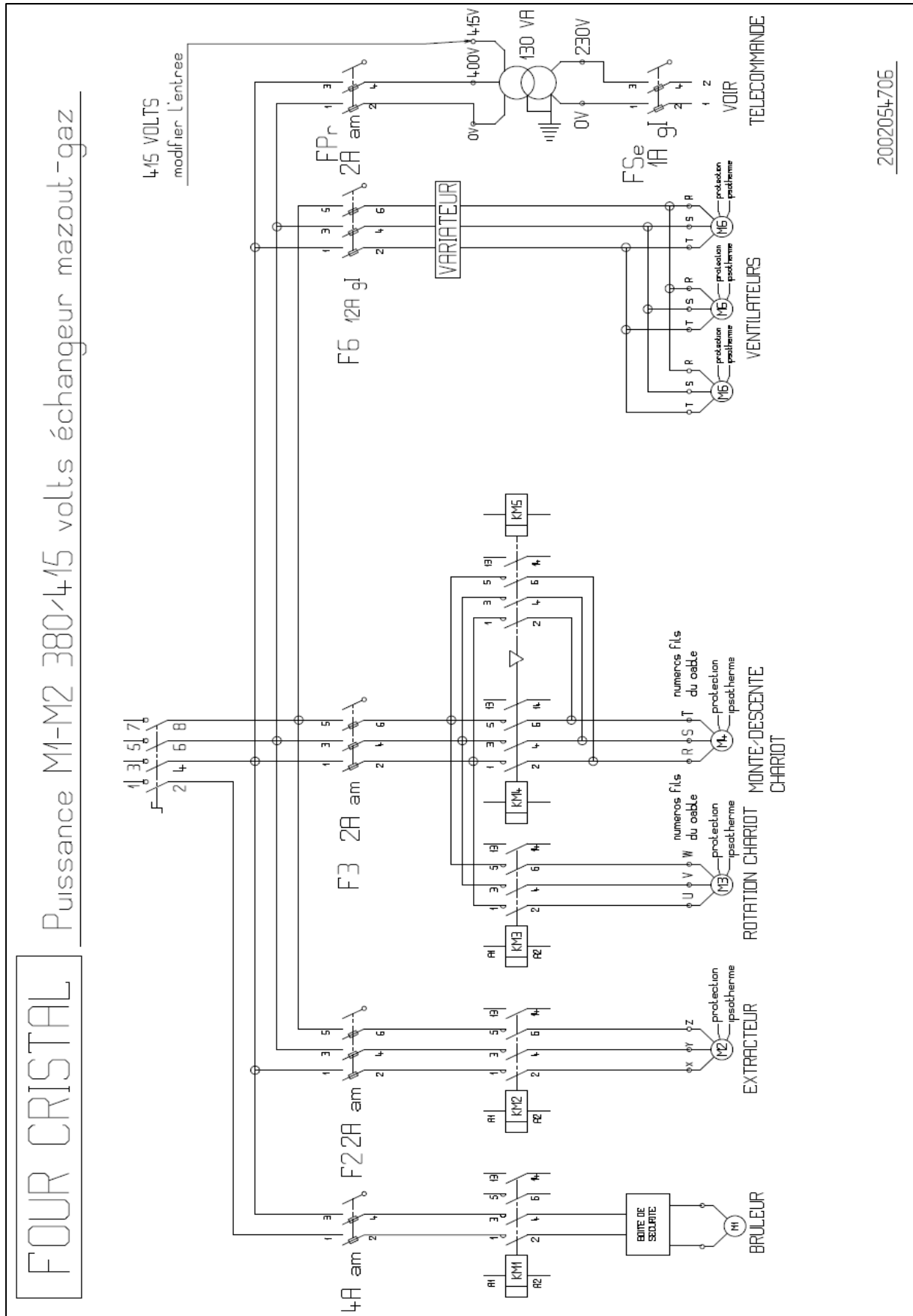

7.6. ELECTRIC FM1/2 POWER DISTRIBUTION DIAGRAM WITH SPEED VARIATOR

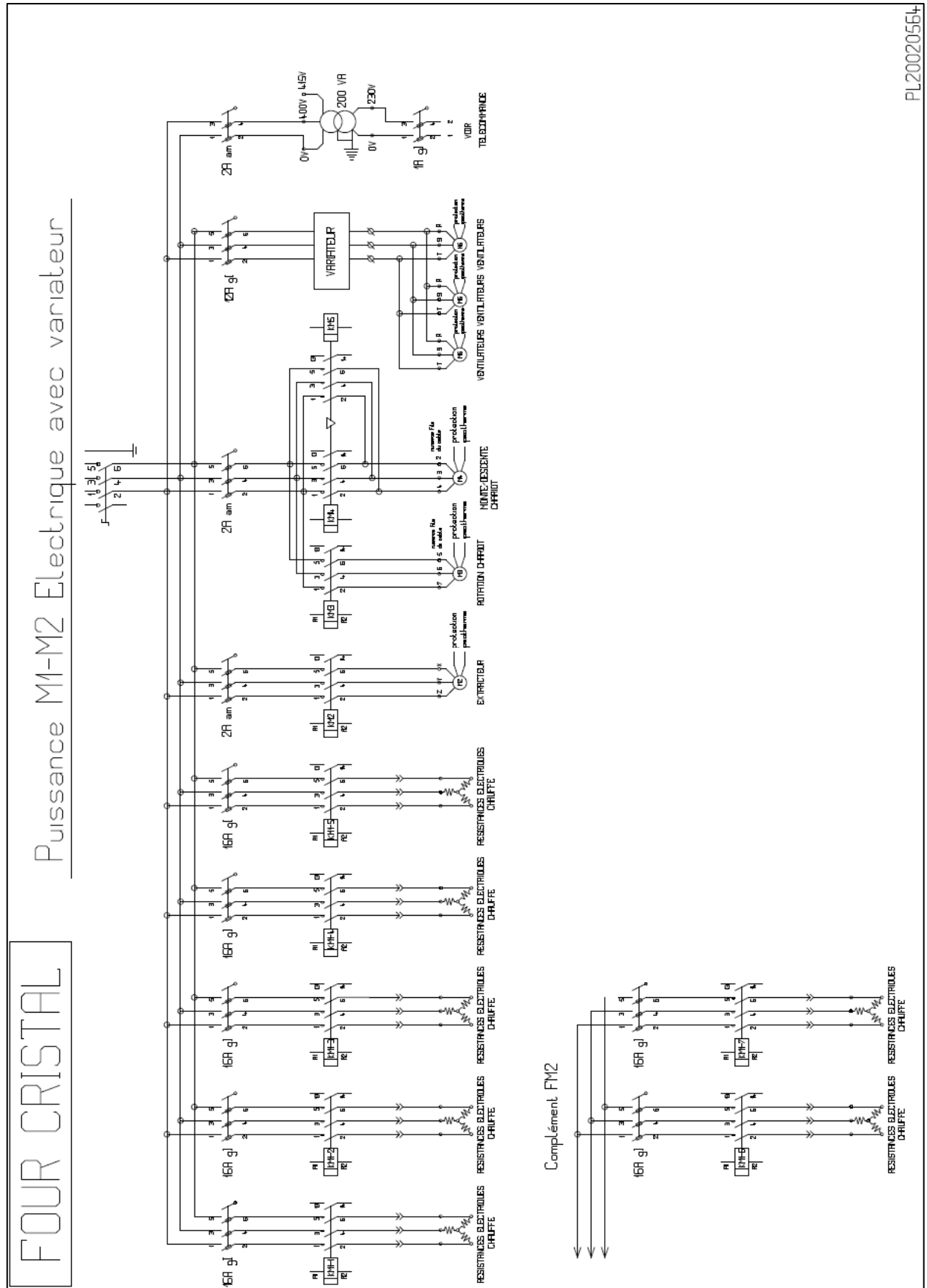

7.7. DELAT ELECTRIC VARIATOR

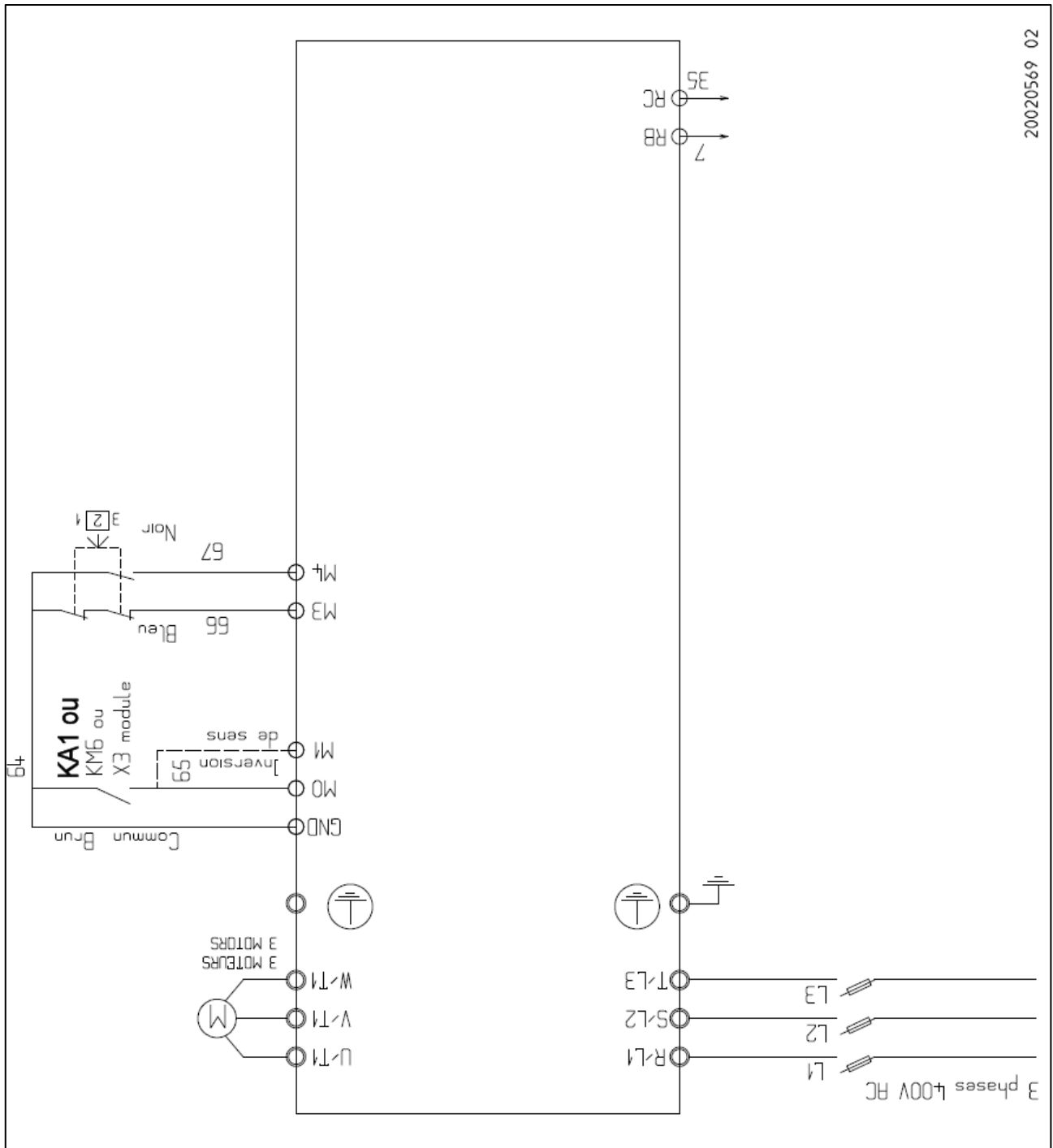

20020569 02

ROOF DISTRIBUTION BOX WIRING

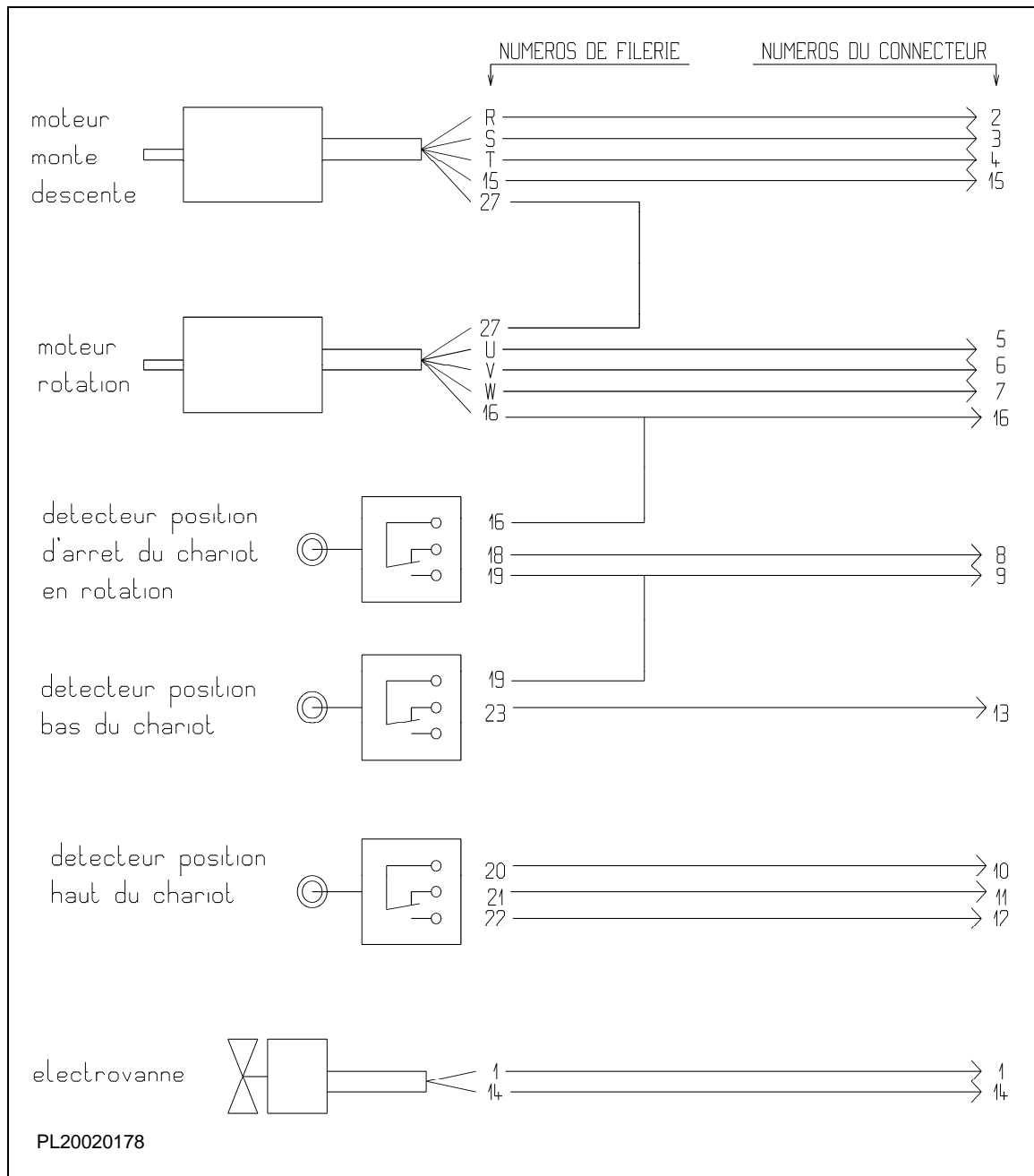

7.8. OIL/GAS CONTROL DIAGRAM

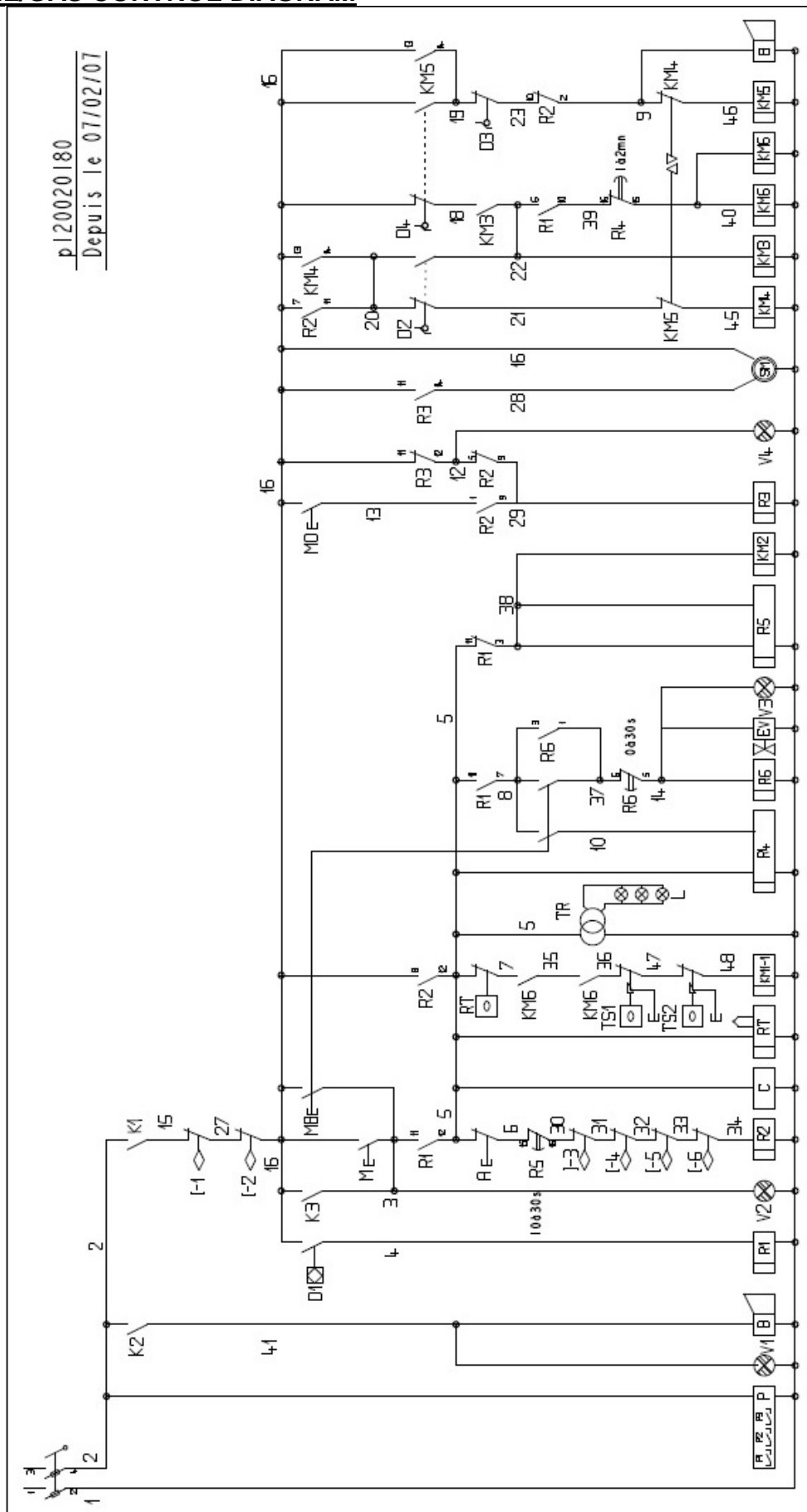

OIL/GAS CONTROL DIAGRAM

M	Marche four sans buée	D1	Détecteur inductif présence de porte
MB	Marche four avec buée	D2	Détecteur de position haute du chariot
MO	Marche OURA (ouvert, fermé)	D3	Détecteur de position basse du chariot
A	Arrêt four	D4	Détecteur de rotation du chariot
P	Programmateur des temps de cuisson et différé	V1	Voyant jaune de fin de cuisson
P1	Contact de sortie cuisson programmateur	V2	Voyant marche du four
P2	Contact de sortie différé programmateur	V3	Voyant d'injection de buée
P3	Contact de sortie impulsion programmateur	V4	Voyant d'ouverture du OURA
I-1	Ipsotherme de protection moteur montée/descente chariot	TR	Transfo d'éclairage
I-2	Ipsotherme de protection moteur rotation du chariot	L	Lampe halogène
I-3	Ipsotherme de protection moteur extracteur de buée	RT	Régulateur de température du four
I-4	Ipsotherme de protection moteur turbine ventilation haute	B	Buzzer 2 tons (cuisson, descente chariot)
I-5	Ipsotherme de protection moteur turbine ventilation milieu	C	Compteur horaire
I-6	Ipsotherme de protection moteur turbine ventilation basse	SM	Servomoteur OURA
R1	Relais de présence porte		
R2	Relais marche du four		
R3	Térupteur d'ouverture fermeture du OURA		
R4	Relais temporise d'arrêt des turbines ventilation		
R5	Relais temporise d'arrêt four		
R6	Relais temporise d'injection de buée		
KM1-1	Contacteur de chauffe du four		
KM2	Contacteur de l'extracteur des buées		
KM3	Contacteur de rotation du chariot du four		
KM4	Contacteur de montée du chariot du four		
KM5	Contacteur de descente du chariot du four		
KM6	Contacteur des turbines ventilation four		
TS-1	Thermostat de sécurité du four		
TS-2	Thermostat des fumées du four		
S	Sonnerie de défaut du brûleur		

7.9. ELECTRIC CONTROL DIAGRAM

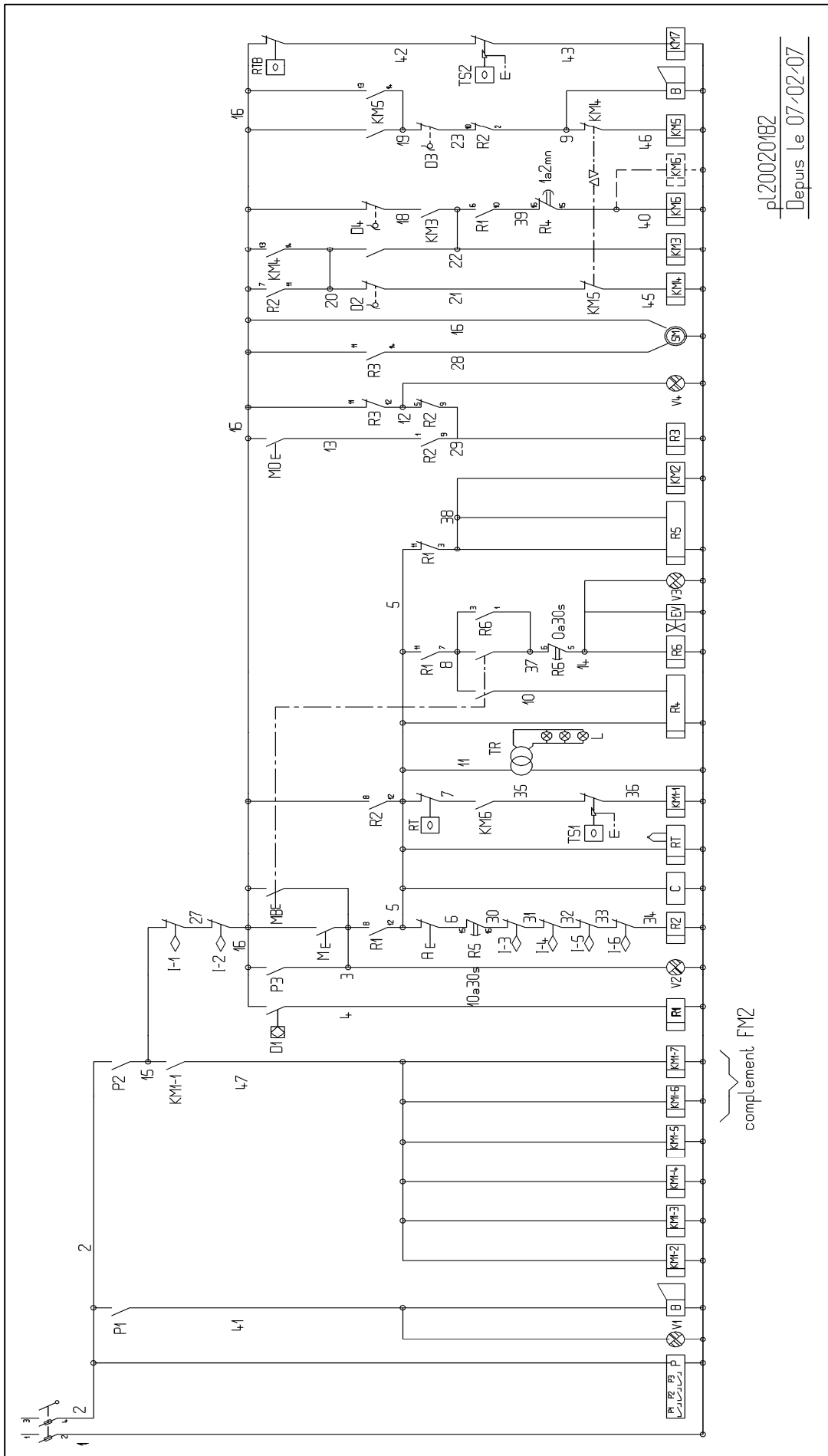

p.L20020182
Depuis Le 07/02/07

ELECTRIC CONTROL DIAGRAM

M	Marche four sans buée	D1	Détecteur inductif présence de porte
MB	Marche four avec buée	D2	Détecteur de position haute du chariot
MO	Marche OURA (ouvert, fermé)	D3	Détecteur de position basse du chariot
A	Arrêt four	D4	Détecteur de rotation du chariot
P	Programmateur des temps de cuisson et différé	V1	Voyant jaune de fin de cuisson
P1	Contact de sortie cuisson programmateur	V2	Voyant marche du four
P2	Contact de sortie différé programmateur	V3	Voyant d'injection de buée
P3	Contact de sortie impulsion programmateur	V4	Voyant d'ouverture du OURA
I-1	Ipsitherme de protection moteur montée/descente chariot	TR	Transfo d'éclairage
I-2	Ipsitherme de protection moteur rotation du chariot	L	Lampe halogène
I-3	Ipsitherme de protection moteur extracteur de buée	RT	Régulateur de température du four
I-4	Ipsitherme de protection moteur turbine ventilation haute	B	Buzzer 2 tons (cuisson, descente chariot)
I-5	Ipsitherme de protection moteur turbine ventilation milieu	SM	Servomoteur OURA
I-6	Ipsitherme de protection moteur turbine ventilation basse	C	Compteur horaire
R1	Relais de présence porte	TS-1	Thermostat de sécurité du four
R2	Relais marche du four	KM1-8	Contacteur n°8 de chauffe du four M3
R3	Télerupteur d'ouverture fermeture du OURA	KM1-9	Contacteur n°9 de chauffe du four M3
R4	Relais temporise d'arrêt des turbines ventilation	KM1-10	Contacteur n°10 de chauffe du four M3
R5	Relais temporise d'arrêt four	KM2	Contacteur de l'extracteur des buées
R6	Relais temporise d'injection de buée	KM3	Contacteur de rotation du chariot du four
KM1-1	Contacteur n°1 de chauffe du four	KM4	Contacteur de montée du chariot du four
KM1-2	Contacteur n°2 de chauffe du four	KM5	Contacteur de descente du chariot du four
KM1-3	Contacteur n°3 de chauffe du four	KM6	Contacteur des turbines ventilation du four
KM1-4	Contacteur n°4 de chauffe du four		
KM1-5	Contacteur n°5 de chauffe du four		
KM1-6	Contacteur n°6 de chauffe du four M2-M3		
KM1-7	Contacteur n°7 de chauffe du four M2-M3		

7.10. CONTROL KEYBOARD

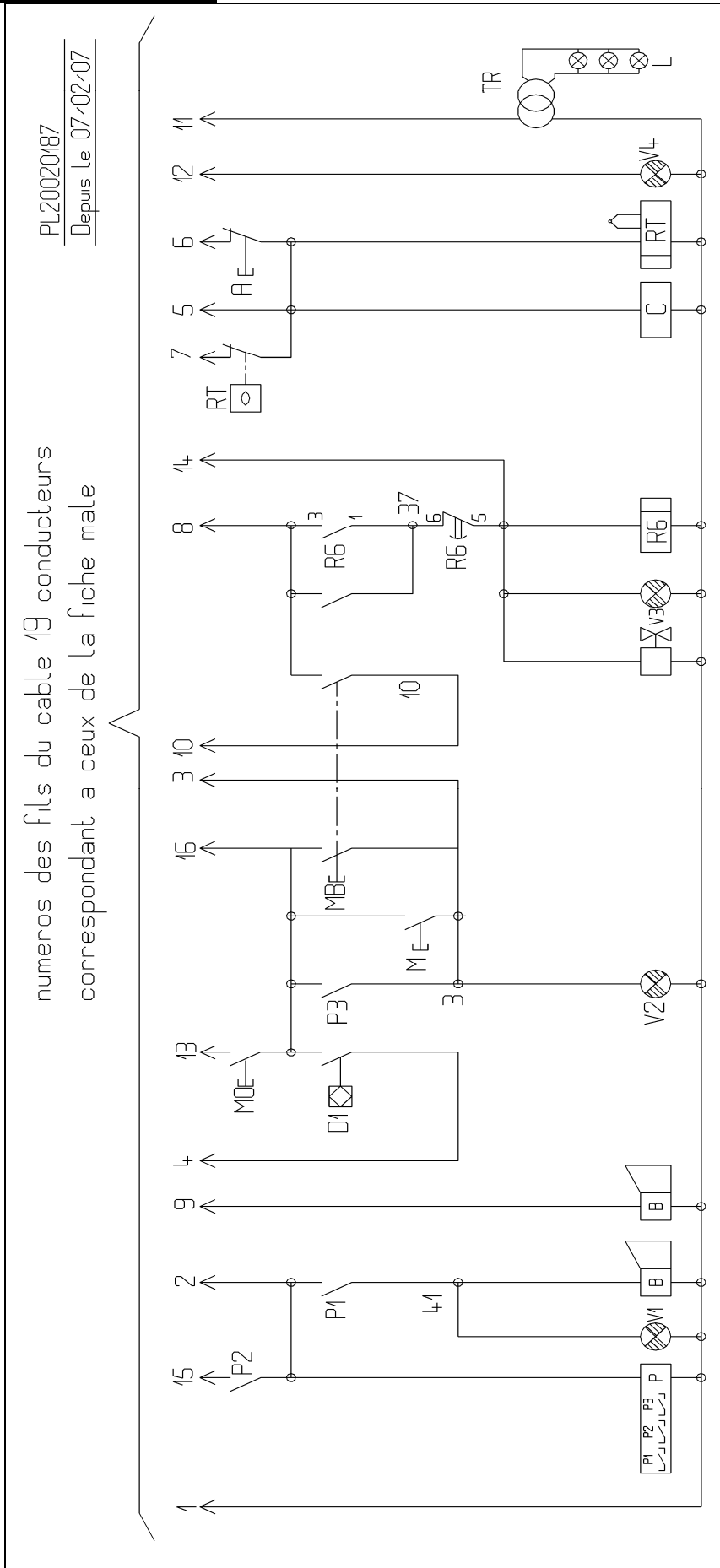

PL20020187

R6	Relais temporisé d'injection de buée	D1	Détecteur inductif présence de porte
S	Sonnerie de défaut du brûleur	V1	Voyant jaune de fin de cuisson
M	Marche four sans buée	V2	Voyant marche du four
MB	Marche four avec buée	V3	Voyant d'injection de buée
MO	Marche OURA (ouvert, fermé)	V4	Voyant d'ouverture du OURA
A	Arrêt four	L	Lampe halogène
P1	Contact de sortie cuisson programmeur	RT	Régulateur de température du four
P2	Contact de sortie différé programmeur	B	Buzzer 2 tons (cuisson, descente chariot)
P3	Contact de sortie impulsion programmeur	C	Compteur horaire

7.11. OIL/GAS CONTROL DIAGRAM WITH PROTOUCH AND SPEED VARIATOR

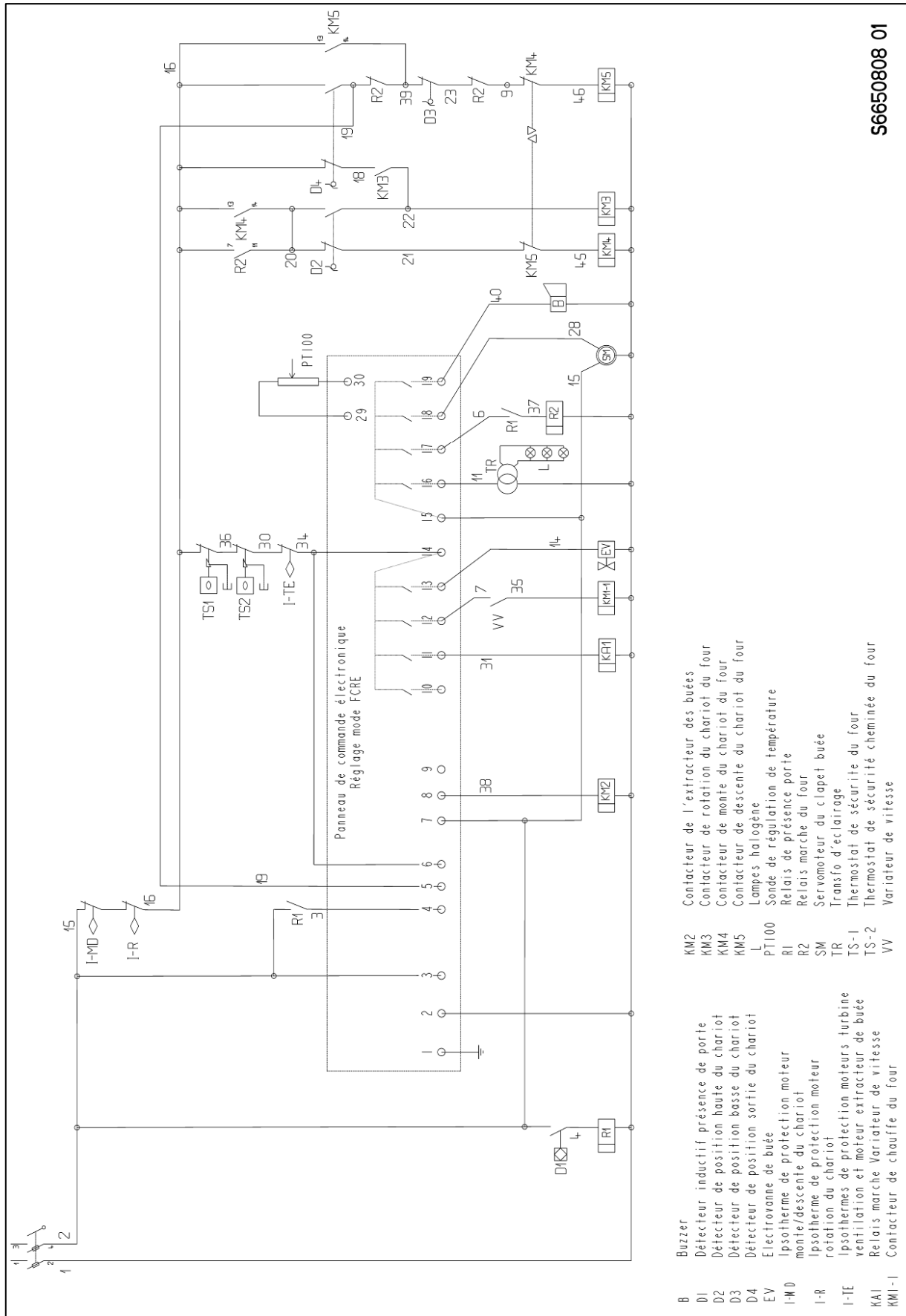

- | | | | |
|-------|--|-------|---|
| B | Buzzer | KM2 | Contacteur de l'extracteur des buées |
| D1 | Détecteur inductif présence de porte | KM3 | Contacteur de rotation du chariot du four |
| D2 | Détecteur de position haute du chariot | KM4 | Contacteur de monte du chariot du four |
| D3 | Détecteur de position basse du chariot | KM5 | Contacteur de descente du chariot du four |
| D4 | Détecteur de position sortie du chariot | L | Lampes halogène |
| EV | Electrovanne de buée | PT100 | Sonde de régulation de température |
| I-M0 | Ipsitherme de protection moteur monte/descente du chariot | R1 | Relais de présence porte |
| I-R | Ipsitherme de protection moteur rotation du chariot | R2 | Relais marche du four |
| I-TE | Ipsithermes de protection moteurs turbine ventilation et moteur extracteur de buée | SM | Servomoteur du clapet buée |
| KAI | Relais marche Variateur de vitesse | TR | Transfo d'éclairage |
| KMI-1 | Contacteur de chauffe du four | TS-1 | Thermostat de sécurité du four |
| | | TS-2 | Thermostat de sécurité cheminée du four |
| | | VV | Variateur de vitesse |

7.12. ELECTRIC CONTROL DIAGRAM WITH PROTOUCH AND SPEED VARIATOR

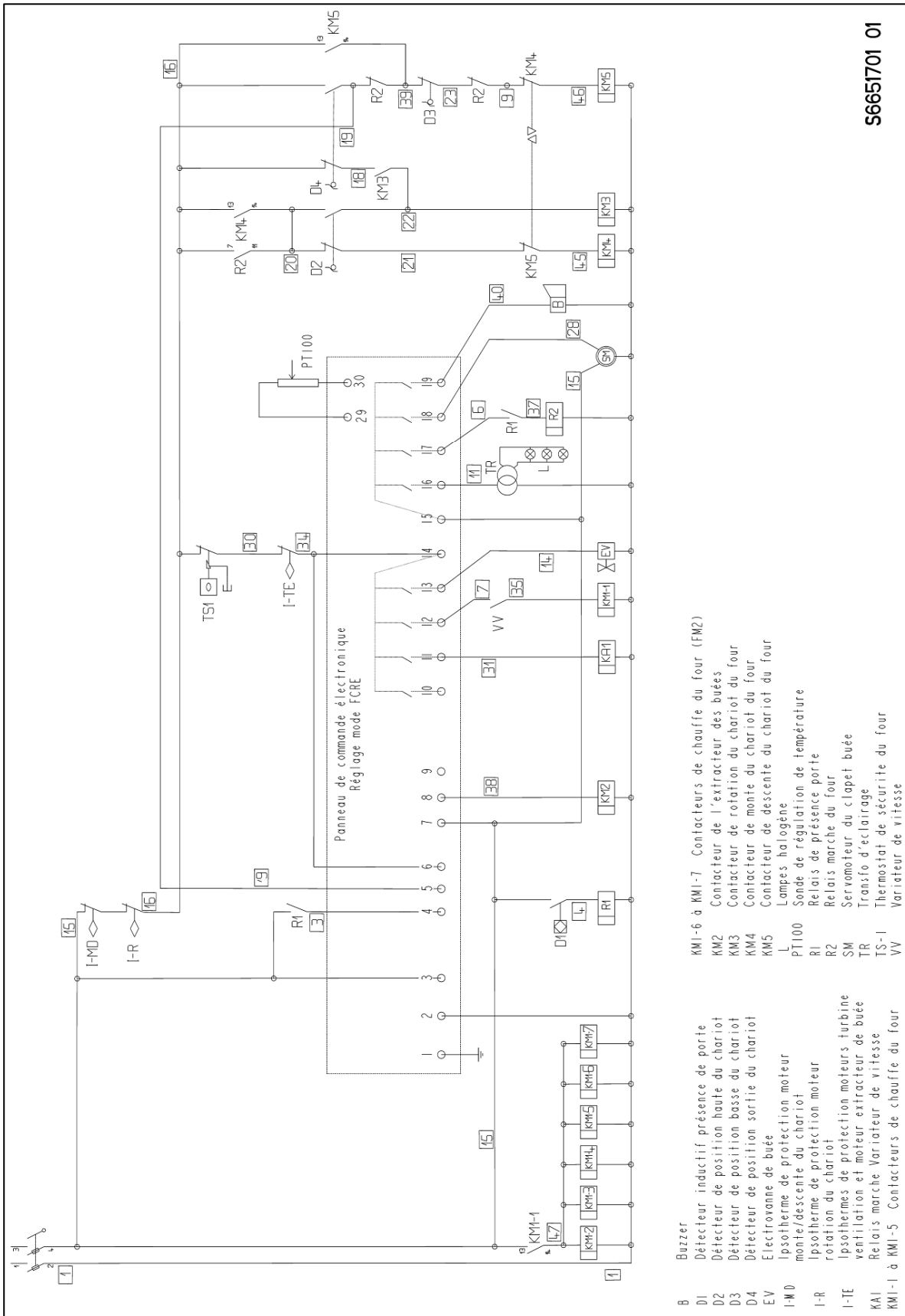

- B Buzzer
- D1 Détecteur inductif présence de porte
- D2 Détecteur de position haute du charriot
- D3 Détecteur de position basse du charriot
- D4 Détecteur de position sortie du charriot
- EV Electrovanne de buée
- I-MD Isotherme de protection moteur monte/descende du chariot
- I-R Isotherme de protection moteur rotation du charriot
- I-TE Isothermes de protection moteurs turbine ventilation et moteur extracteur de buée
- KM1 Relais marche Variateur de vitesse
- KM1-1 à KM1-5 Contacteurs de chauffe du four
- KM1-6 à KM1-7 Contacteurs de chauffe du four (FM2)
- KM2 Contacteur de l'extracteur des buées
- KM3 Contacteur de rotation du charriot du four
- KM4 Contacteur de monte du chariot du four
- KM5 Contacteur de descente du charriot du four
- L Lampes halogène
- PT100 Sonde de régulation de température
- R1 Relais de présence porte
- R2 Relais marche du four
- SM Servomoteur du clapet buée
- TR Transfo d'éclairage
- TS-1 Thermostat de sécurité du four
- VV Variateur de vitesse

8. PARTS LIST

8.1. ELECTRIC OVEN GENERAL PARTS LIST

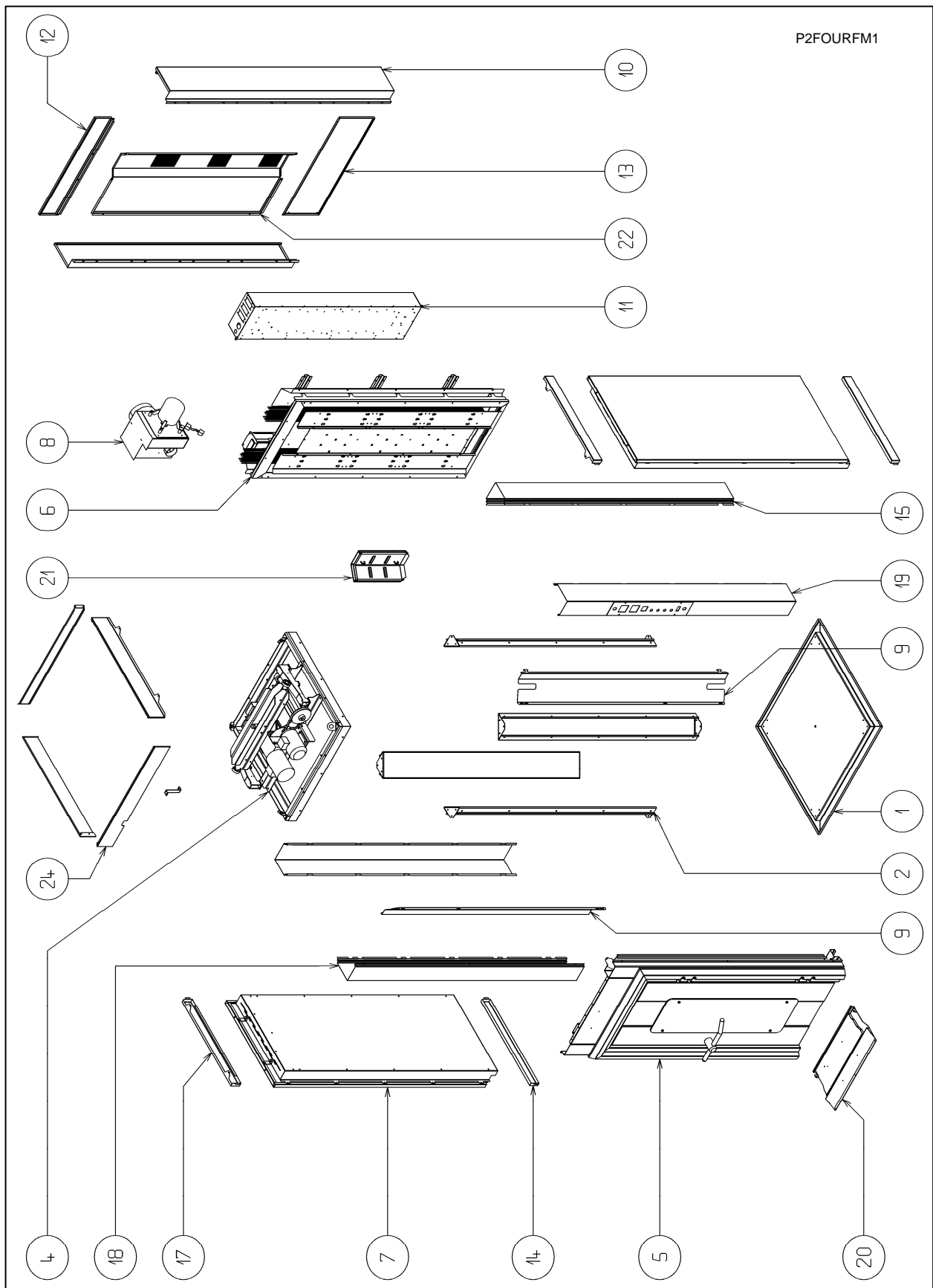

Electric oven

Rep.	Désignation		M1	M2	
1	Plancher		AF220005151	AF220005051	
2	Pilier		AF220005176	AF220005054	
4	Plafond	Porte droite	400V	AF220005611	AF220005612
			208/230V	AF220006590	AF220006591
	Porte gauche	400V	AF220014591	AF220014593	
		208/230V	AF220014590	AF220014592	
5	Bloc porte		droit	AF220005600	AF220005601
			gauche	AF220014520	AF220014540
6	Bloc chauffe		50Hz	AF220005607	AF220005608
			60Hz	AF220006650	AF220006651
7	Panneau		AF220005192	AF220005135	
8	Extracteur		AF220005604	AF220005605 →10/00 11/00→ AF220006670	
9	Tôle calorifuge avant		AF220005439	AF220005446	
10	Jaquette latérale		AF220005687	AF220005688	
11	Coffret électrique		400 V	AF220005731	AF220005733
			208/230V	AF220005732	AF220005734
12	Traverse arrière haute		AF220005690	AF220005691	
13	Traverse arrière basse		AF220005692	AF220005693	
14	Plinthe		AF220005183	AF220005120	
15	Angle arrière		AF220005199	AF220005121	
17	Bandeau		AF220005184	AF220005122	
18	Angle avant		AF220005148	AF220005124	
19	Angle avant droit câblé		50 Hz	AF220005715	AF220005726
			60 Hz	AF220005782	AF220005783
	Angle avant gauche câblé		50 Hz	AF220005737	AF220005738
			60 Hz	AF220005785	AF220005786
20	Pan incliné		Porte droite	AF220005626	AF220005627
			Porte gauche	AF220014500	AF220014506
21	Boîte à buée		AF220005668	AF220005670	
22	Jaquette arrière		AF220005699	AF220005128	
24	Ceinture supérieure				
COMPRENANT					
	Ceinture avant		Porte droite	AF220005655	AF220005658
			Porte gauche	AF220014580	AF220014581
	Ceinture latérale		AF220005656	AF220005659	
	Ceinture arrière		AF220005657	AF220005660	
	Support		AF220005664	AF220005664	

8.2. OIL/GAS OVEN REAR PARTS LIST

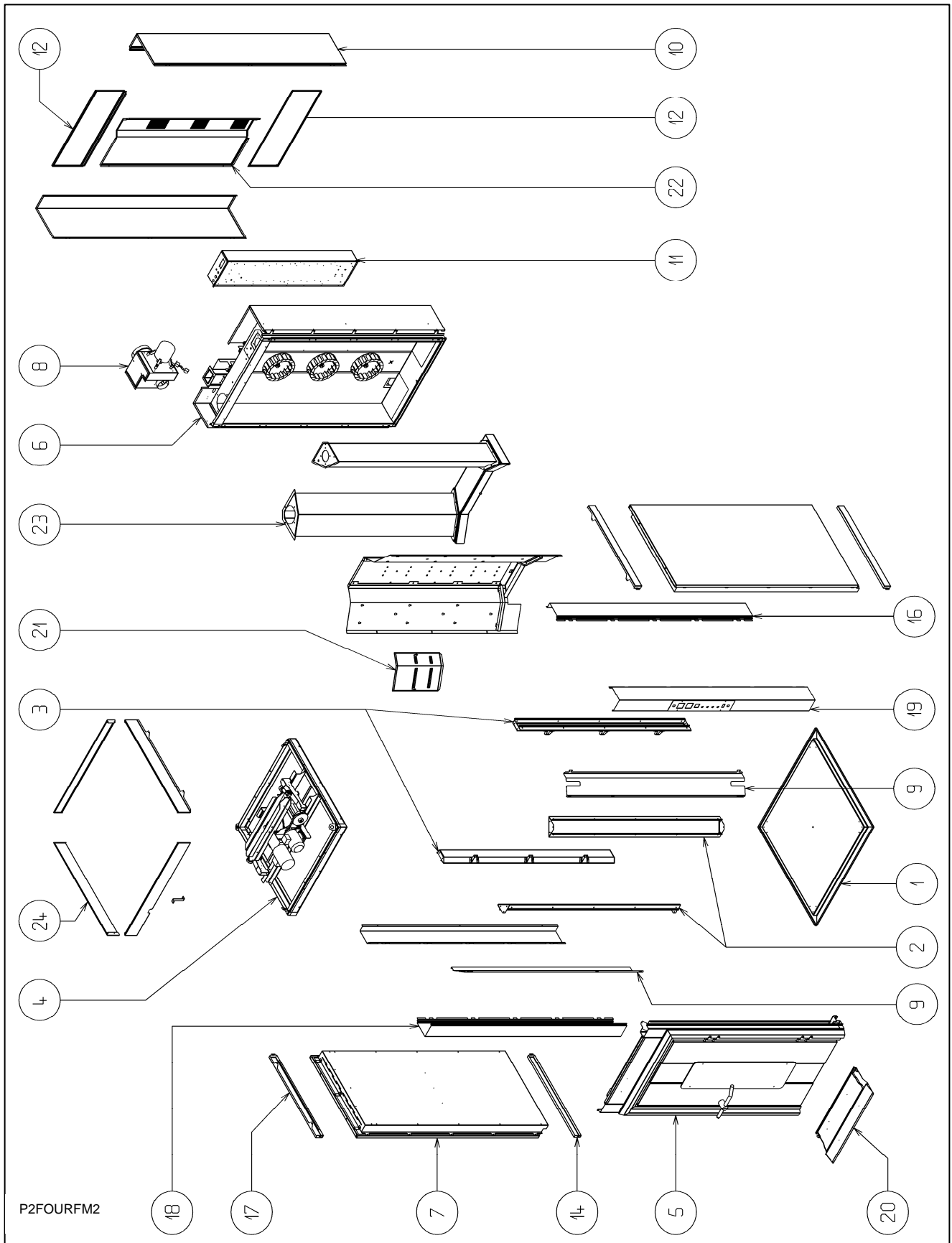

Oil/gas oven rear

Rep.	Désignation		M1	M2	
1	Plancher		AF220005151	AF220005051	
2	Pilier standard		AF220005176	AF220005054	
3	Pilier Mazout/Gaz		AF220005470	AF220005471	
4	Plafond	Porte droite	400V	AF220005611	AF220005612
			208/230V	AF220006590	AF220006591
		Porte gauche	400V	AF220014591	AF220014593
			208/230V	AF220014590	AF220014592
5	Bloc porte	Droit	AF220005600	AF220005601	
		Gauche	AF220014520	AF220014540	
6	Bloc chauffe	50Hz	AF220005615	AF220005616	
		60Hz	AF220006655	AF220006656	
7	Panneau		AF220005192	AF220005135	
8	Extracteur		AF220005604	AF220005605 →10/00	
				11/00→ AF220006670	
9	Tôle calorifuge avant		AF220005439	AF220005446	
10	Jaquette latérale bloc chauffe		AF220005694	AF220005695	
11	Coffret électrique	400V	AF220005729	AF220005729	
		208/230V	AF220005730	AF220005730	
12	Traverse arrière bloc chauffe		AF220005697	AF220005698	
14	Plinthe		AF220005183	AF220005120	
16	Angle arrière Mazout/Gaz		AF220005570	AF220005585	
17	Bandeau		AF220005184	AF220005122	
18	Angle avant		AF220005148	AF220005124	
19	Angle avant droit câblé	50 Hz	AF220005715	AF220005726	
		60 Hz	AF220005782	AF220005783	
	Angle avant gauche câblé	50 Hz	AF220005737	AF220005738	
		60 Hz	AF220005785	AF220005786	
20	Pan incliné	Porte droite	AF220005626	AF220005627	
		Porte gauche	AF220014500	AF220014506	
21	Boîte à buée		AF220005669	GA AF220005671	
				DR AF220005672	
22	Jaquette arrière bloc chauffe		AF220005699	AF220005699	
23	Echangeur		AF220005619	AF220005620	
24	Ceinture supérieure				
	COMPRENANT				
	Ceinture avant	Porte droite	AF220005655	AF220005658	
		Porte gauche	AF220014580	AF220014581	
	Ceinture latérale		AF220005656	AF220005659	
	Ceinture arrière		AF220005657	AF220005660	
	Support		AF220005664	AF220005664	

8.3. GENERAL PARTS LIST FOR OIL/GAS OVEN SIDE

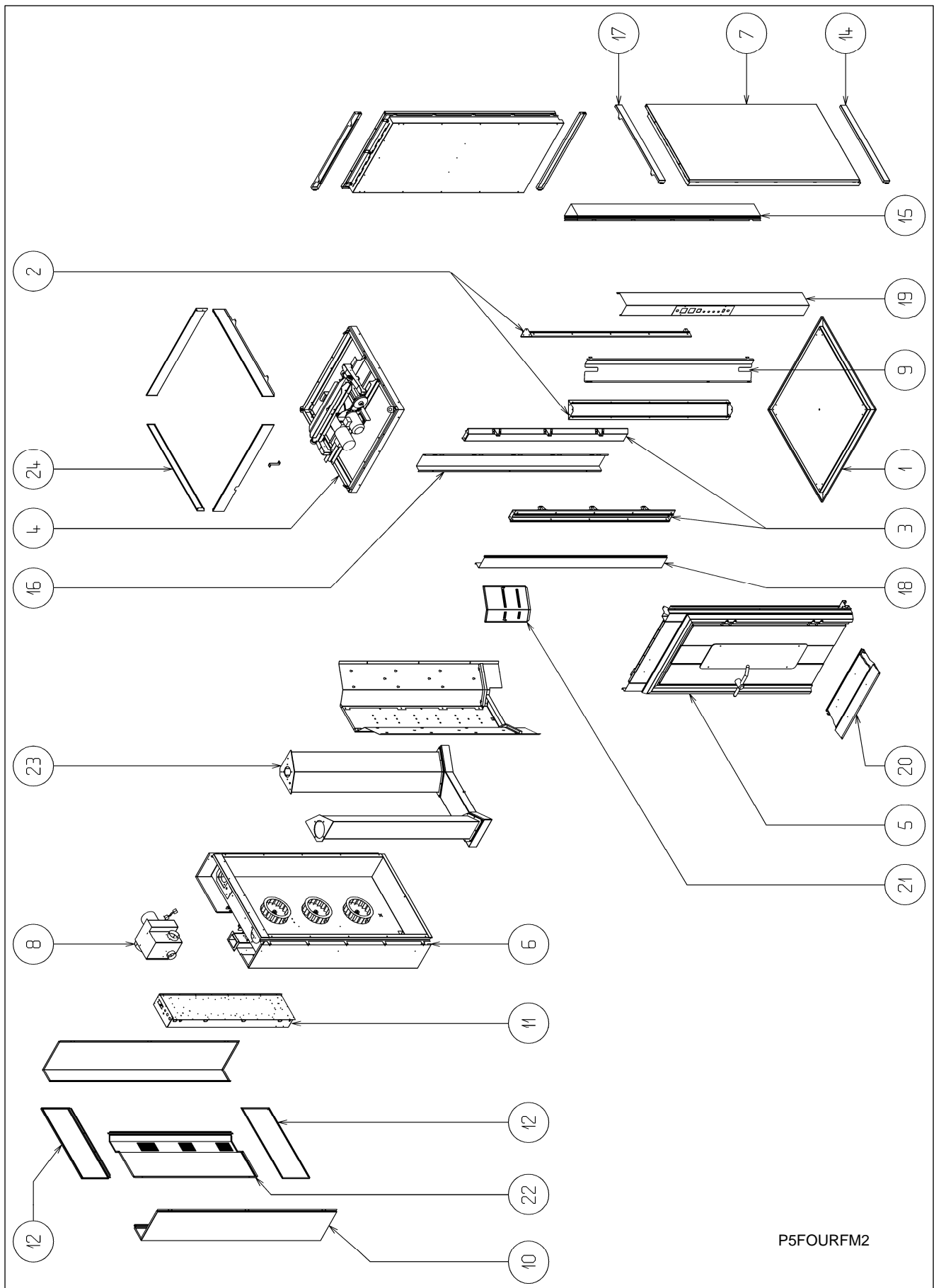

Oil/gas oven side

Rep.	Désignation		M1	M2	
1	Plancher		AF220005151	AF220005051	
2	Pilier standard		AF220005176	AF220005054	
3	Pilier Mazout/Gaz		AF220005470	AF220005471	
4	Plafond	Porte droite	400V	AF220005611	AF220005612
			208/230V	AF220006590	AF220006591
		Porte gauche	400V	AF220014591	AF220014593
			208/230V	AF220014590	AF220014592
5	Bloc porte	droit	AF220005600	AF220005601	
		gauche	AF220014520	AF220014540	
6	Bloc chauffe	50Hz	AF220005615	AF220005616	
		60Hz	AF220006655	AF220006656	
7	Panneau		AF220005192	AF220005135	
8	Extracteur		AF220005604	AF220005605 →10/00 11/00→ AF220006670	
9	Tôle calorifuge avant		AF220005439	AF220005446	
10	Jaquette latérale bloc chauffe		AF220005694	AF220005695	
11	Coffret électrique	400V	AF220005729	AF220005729	
		208/230V	AF220005730	AF220005730	
12	Traverse arrière bloc chauffe		AF220005697	AF220005698	
14	Plinthe		AF220005183	AF220005120	
15	Angle arrière		AF220005199	AF220005121	
16	Angle arrière Mazout/Gaz		AF220005570	AF220005585	
17	Bandeau		AF220005184	AF220005122	
18	a) Angle avant Mazout/Gaz		AF220005587	AF220005572	
	b) Angle avant GAU câblé	50 Hz	AF220005737	AF220005738	
		60 Hz	AF220005785	AF220005786	
19	a) Angle avant DROIT câblé	50 Hz	AF220005715	AF220005726	
		60 HZ	AF220005782	AF220005783	
	b) Angle avant Mazout/Gaz		AF220005587	AF220005572	
20	Pan incliné	Porte droite	AF220005626	AF220005627	
		Porte gauche	AF220014500	AF220014506	
21	Boîte à buée		AF220005669	GA AF220005671 DR AF220005672	
22	Jaquette arrière bloc chauffe		AF220005699	AF220005699	
23	Echangeur		AF220005619	AF220005620	
24	Ceinture supérieure				
	COMPRENANT				
	Ceinture avant	Porte droite	AF220005655	AF220005658	
		Porte gauche	AF220014580	AF220014581	
	Ceinture latérale		AF220005656	AF220005659	
	Ceinture arrière		AF220005657	AF220005660	
	Support		AF220005664	AF220005664	

Note: a) Heating unit on the left
b) Heating unit on the right

8.4. ROOF PARTS LIST 1/3

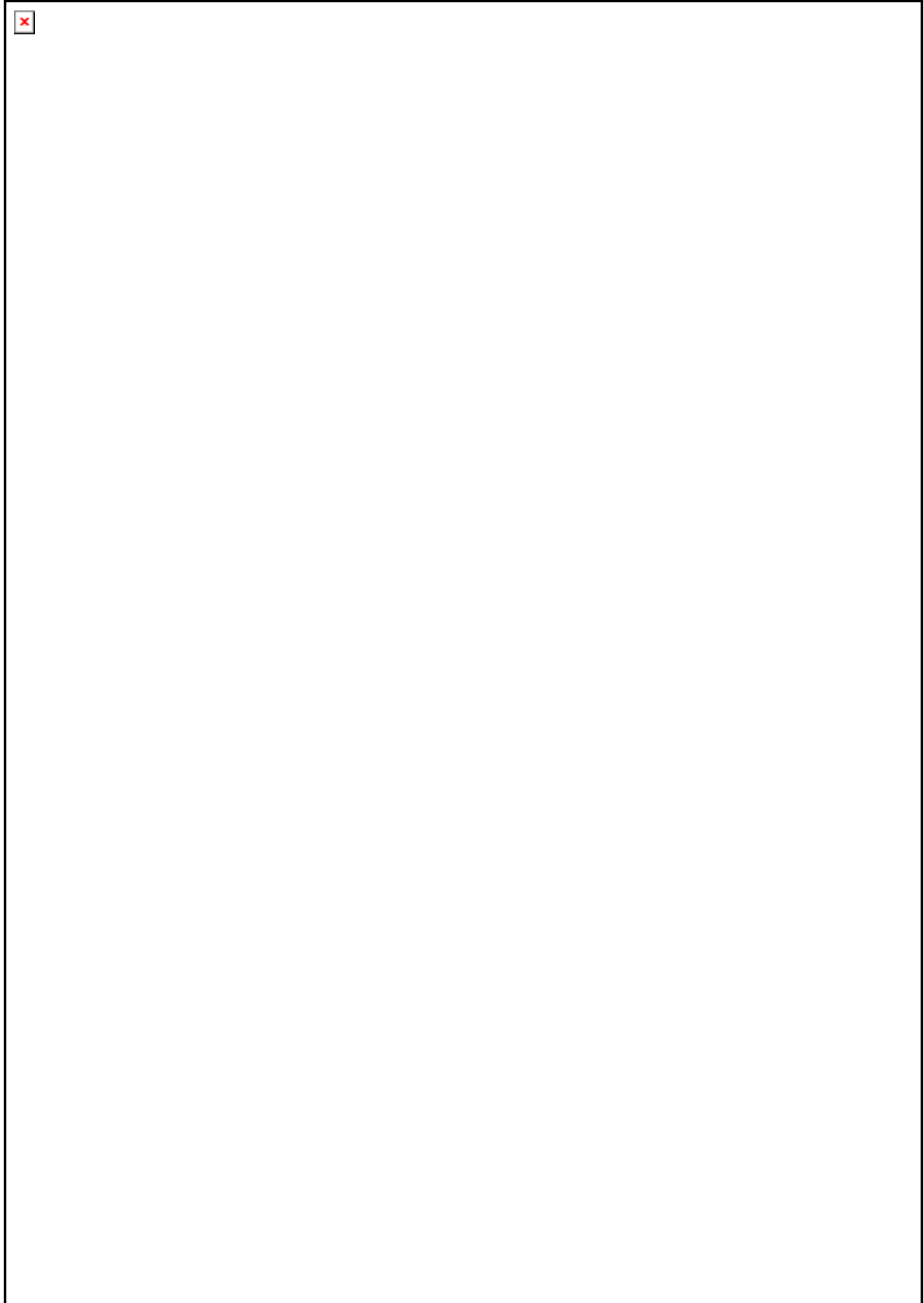

Roof parts list 1/3

Rep.	Désignation		M1	M2
	Plafond monté	Porte droite	400V	Plafond monté
			208/230V	
		Porte gauche	400V	
			208/230V	
	Planche 1			
	COMPRENANT			
1	Plafond soudé		AF220005155	AF220005057
2	Longeron support mécanique		AF220005167	AF220005080
3	Canne relevage		AF220005086	AF220005086
4	Support moto-réducteur		AF220005092	AF220005092
5	Moto-réducteur Rossi * =>12 2006		AF220005003	AF220005003
	Moto-réducteur Bonfiglioli 01 2007=>...		AF220014645	AF220014645
6	Pignon moteur rotation		AF220005004	AF220005004
7	Renfort moto-réducteur		AF220005404	AF220005404
8	Moteur relevage		AF200033920	AF200033920
9	Poulie motrice relevage		AF220005015	AF220005015
10	Courroie		AF200011744	AF200011744
11	Joint angle		AF220005527	AF220005527
12	Entretoise motoreducteur 08 2006=>...		AF220014652	AF220014652

*To replace a Rossi gear motor with a Bonfiglioli gear motor, replace the gear motor mounts 20005092, 20005404 and add 5 spacers 20014652

8.5. ROOF PARTS LIST 2/3

P220005611

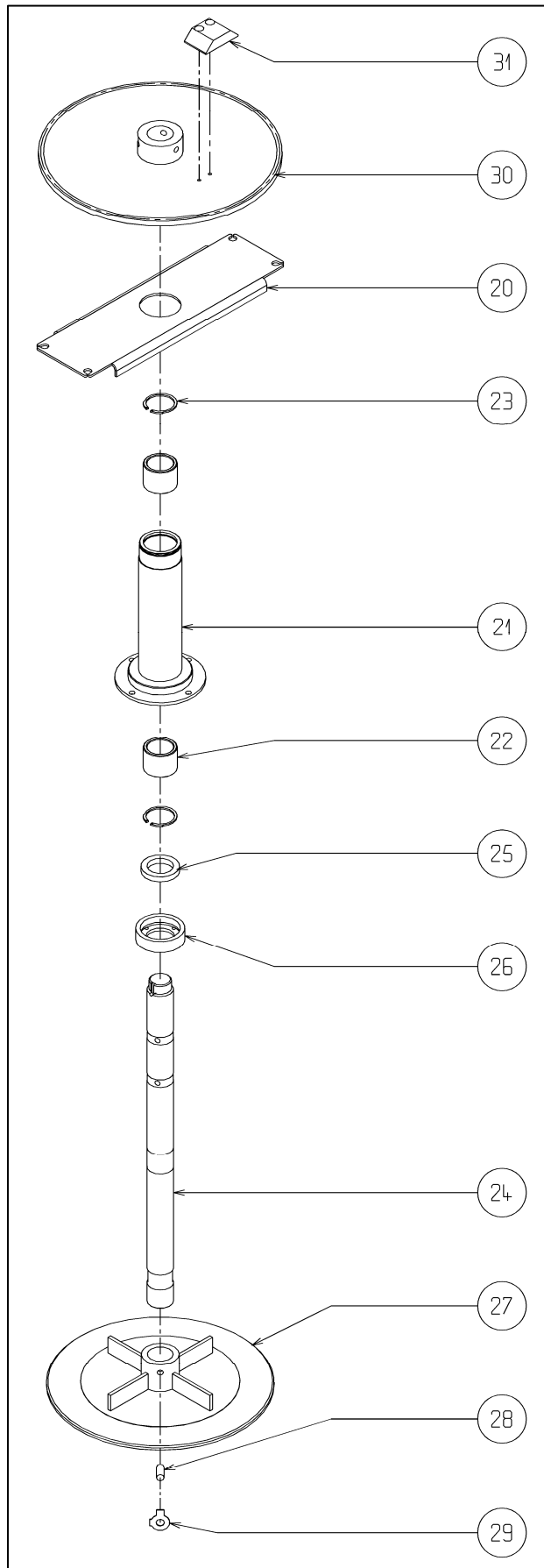

Roof parts list 2/3

Rep.	Désignation	M1	M2
	planche 2		
20	Support palier arbre rotation	AF220005081	AF220005081
21	Palier arbre rotation	AF220005001	AF220005001
22	Bague bronze	AF220005036	AF220005036
23	Circlips	AF200015399	AF200015399
24	Arbre rotation	AF220005000	AF220005000
25	Tresse étanchéité	AF220005017	AF220005017
26	Presse étoupe	AF220005002	AF220005002
27	Plateau support chariot	AF200007332	AF200007332
28	Vis pointeau	AF200032919	AF200032919
29	Rondelle frein	AF200032934	AF200032934
30	Roue 105 dents	AF220005041	AF220005041
31	Pion détection rotation	AF220005486	AF220005486

8.6. ROOF PARTS LIST 3/3

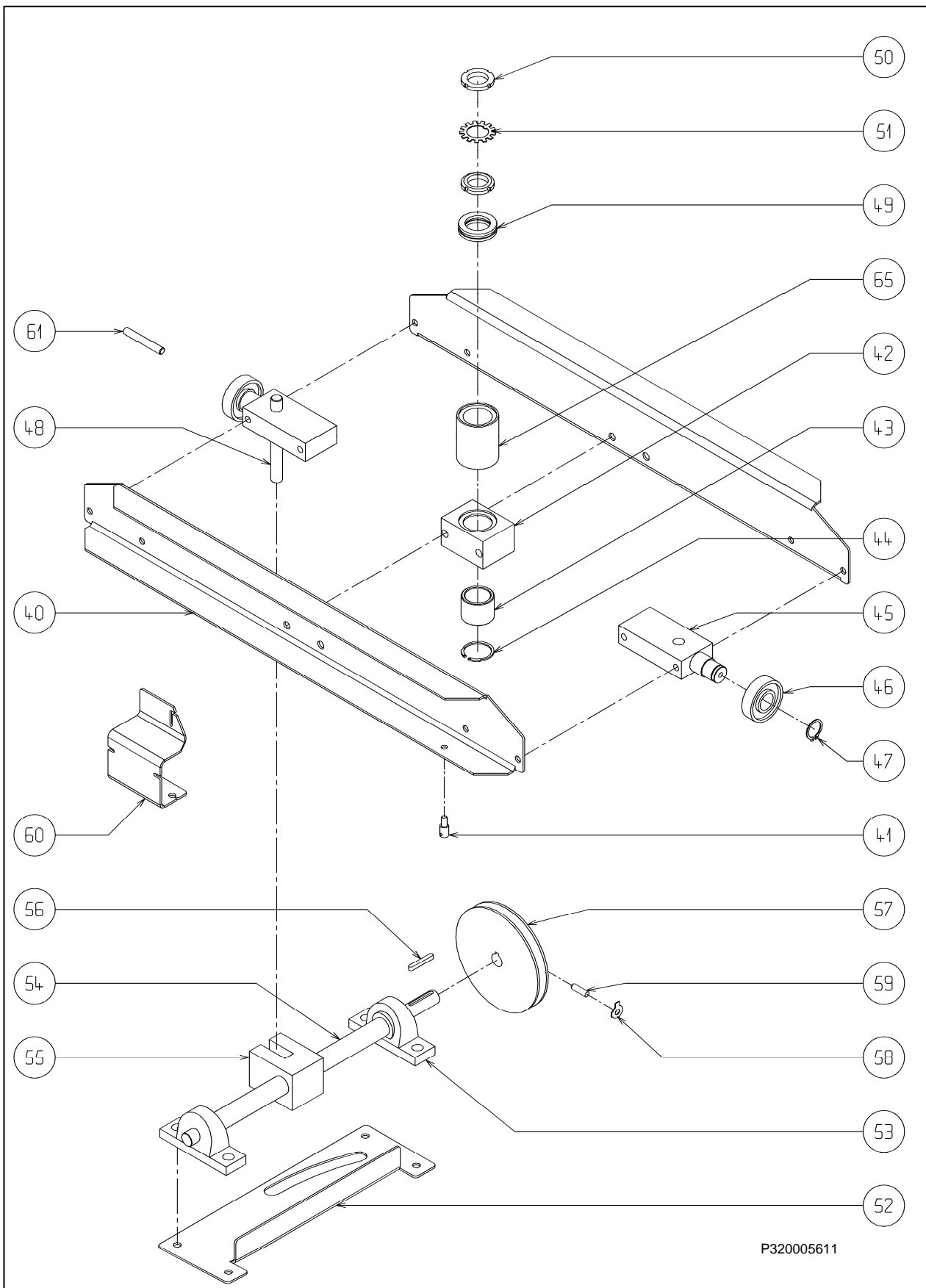

P320005611

Roof parts list 3/3

Rep.	Désignation		M1	M2
	planche 3			
40	Palonnier		AF220005085	AF220005085
41	Axe Câble palonnier		AF220005049	AF220005049
42	Moyeu palonnier		AF220005006	AF220005006
43	Bague bronze		AF220005036	AF220005036
44	Circlips		AF200015399	AF200015399
45	Embout palonnier		AF220005008	AF220005008
46	Roulement		AF220002540	AF220002540
47	Circlips		AF200032899	AF200032899
48	Axe commande palonnier		AF220005009	AF220005009
49	Butée à bille		AF200015201	AF200015201
50	Erou SKF		AF200015602	AF200015602
51	Rondelle SKF		AF200015603	AF200015603
52	Support vis-écrou	Porte droite	AF220005083	AF220005083
		Porte gauche	AF220014597	AF220014597
53	Palier à semelle		AF220005013	AF220005013
54	Vis commande palonnier		AF220005011	AF220005011
55	Erou commande palonnier		AF220005012	AF220005012
56	Clavette		AF220005479	AF220005479
57	Poulie réceptive relevage		AF220005016	AF220005016
58	Rondelle frein		AF200032933	AF200032933
59	Vis pointeau		AF200032830	AF200032830
60	Support détecteur rotation		AF220005144	AF220005144
61	Axe arrêt palonnier FM		AF220005569	AF220005569
	Si cage d'écureuil			
65	Bague réhausse		AF220005007	AF220005007

8.7. DOOR UNIT PARTS LIST 1/3

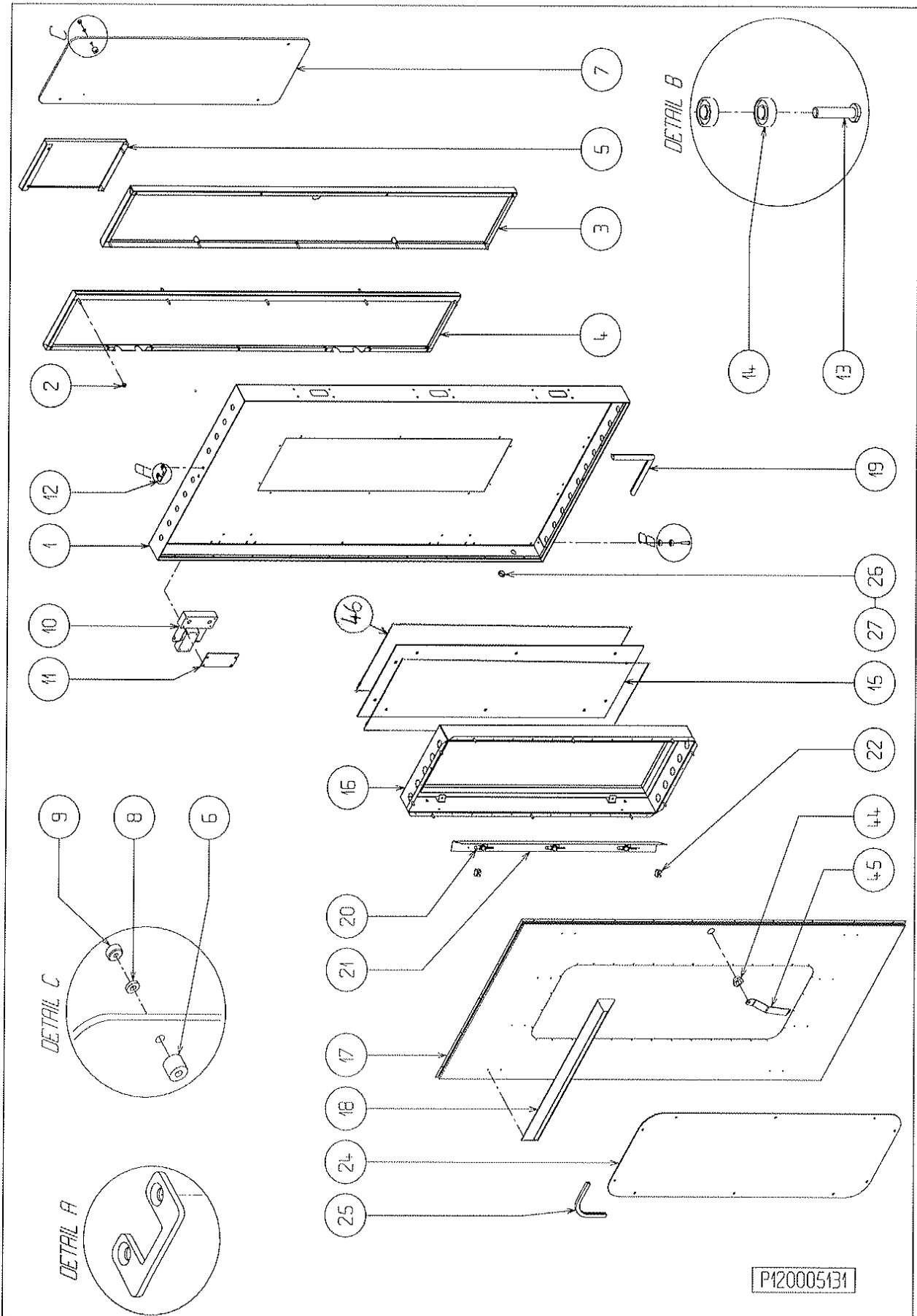

DOOR UNIT PARTS LIST 1/3

Rep.	Désignation		M1	M2
	BLOC PORTE MONTE	AF220005600	AF220005601	20005601
		AF220014520	AF220014540	20014540
	COMPRENANT			
	PORTE MONTEE	AF220005189	AF220005131	20005131
		AF220014535	AF220014555	20014555
	planche 1			
1	Porte soudée	AF220005188	AF220005130	20005130
		AF220014536	AF220014556	20014556
2	Rondelle isolation		AF220005024	AF220005024
3	Panneau poignée		AF220005382	AF220005385
4	Panneau charnière		AF220005383	AF220005386
5	Panneau milieu		AF220005384	AF220005387
6	Entretoise		AF200019111	AF200019111
7	Vitre extérieure		AF220005421	AF220005421
8	Rondelle silicone		AF220005422	AF220005422
9	Ecrou moleté		AF220005026	AF220005026
10	Charnière		AF220005410	AF220005410
11	Renfort charnière		AF220005066	AF220005066
12	Butée crochet		AF220005111	AF220005111
13	Axe roulement		AF220005034	AF220005034
14	Roulement		AF200011890	AF200011890
15	Vitre intermédiaire		AF220005420	AF220005420
16	Ancien cadre intér. porte →11/04		AF220005423	AF220005423
	Cadre intérieur porte 11/04 →		AF220040004	AF220040004
17	Contre porte		AF220005161	AF220005065
18	Protection joint		AF220005292	AF220005293
19	Joint de porte		AF220005031	AF220005032
20	Lampe halogène		AF270035005	AF270035005
21	Tôle + lampe halogène 04/2007→		AF270035004	AF270035004
	Tube fluorescent → 04 /2007		AF200033304 Plus disponible kit de remplacement : AF0DEVI0106	
22	Borne porcelaine		AF200030409	AF200030409
-				
24	Vitre intérieure		AF220005419	AF220005419
25	Joint vitre intérieure		AF220005259	AF220005259
26	Passe fil		AF200033772	AF200033772
27	Ensemble Câble alimentation éclairage		AF220005438	AF220005438
44	Rondelle de calage		AF220005037	AF220005037
45	Poignée intérieure	AF220005118	AF220005118	20005118
		AF220014584	AF220014584	20014584
46	Joint silicone 13 x 1.5 ht		AF200031333	AF200031333

8.8. DOOR UNIT PARTS LIST 2/3

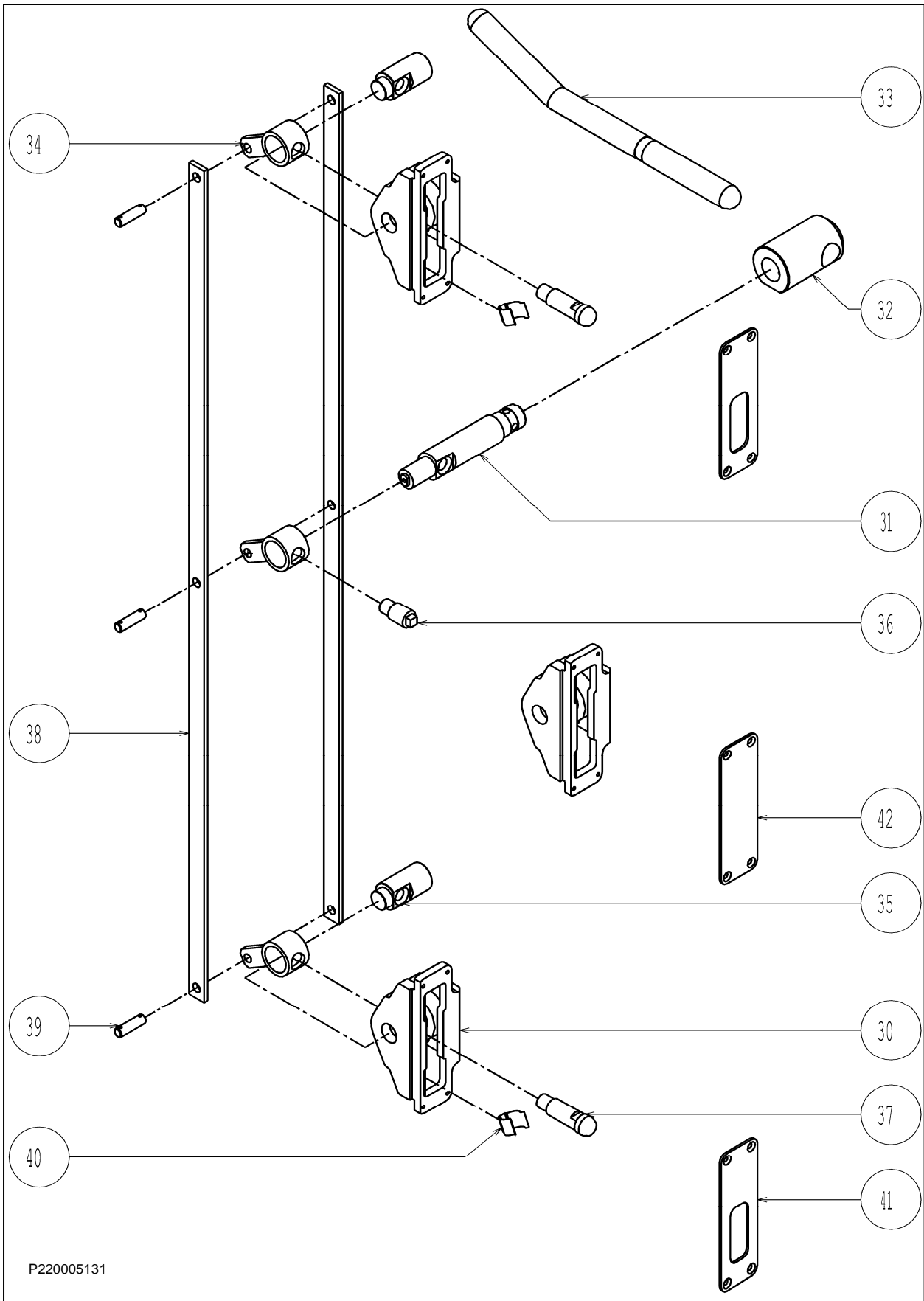

P220005131

DOOR UNIT PARTS LIST 2/3

Rep.	Désignation	M1	M2
30	Bloc verrou	AF220001080	AF220001080
31	Axe poignée	AF220005021 →11/04: AF220006071	AF220005021 →11/04: AF220006071
32	Axe extérieur poignée	AF220005035	AF220005035
33	Poignée	AF220005022	AF220005022
34	Bielle verrou	-	AF220011257
35	Axe renvoi	-	AF220005483
36	Axe verrou	-	AF220005482
37	Pène	AF200007063	AF200007063
38	Biellette verrou	-	AF220005484
39	Axe biellette	-	AF220005485
40	Agrafe lyre	AF200001858	AF200001858
41	Contre plaque	AF200007064	AF200007064
42	Contre plaque centrale	-	AF220005271

8.9. DOOR UNIT PARTS LIST 3/3

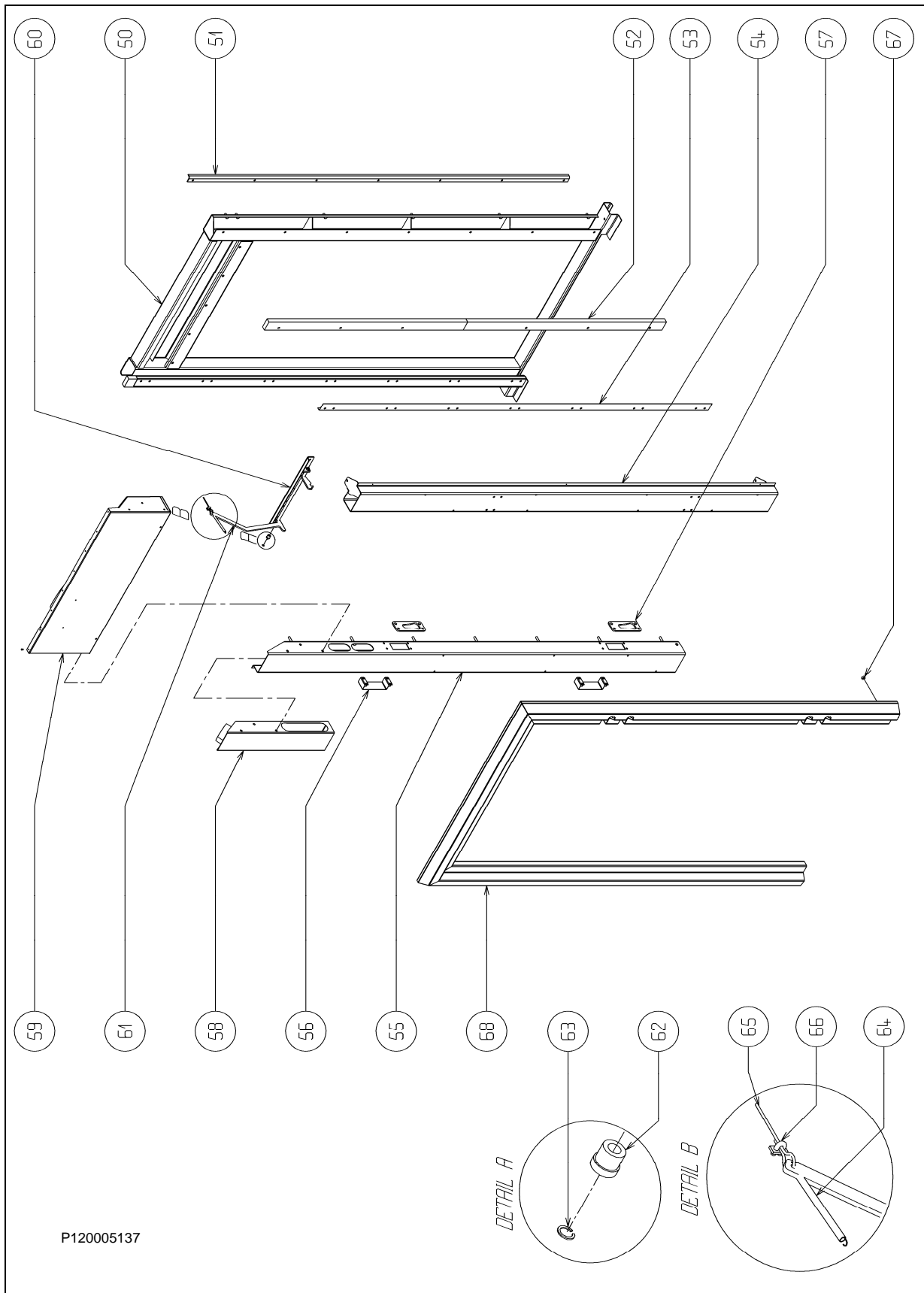

Door unit parts list 3/3

Rep.	Désignation		M1	M2
	CADRE PORTE MONTEE		AF220005187	AF220005137
	planche 3			
	COMPRENANT			
50	Cadre porte soudé		AF220005166	AF220005077
51	Renfort montant		AF220005117	AF220005181
52	Isolant cadre		AF220005257	AF220005258
53	Cache isolant		AF220005119	AF220005408
54	Montant droit	Porte droite	AF220005044	AF220005078
		Porte gauche	AF220014522	AF220014542
55	Montant gauche	Porte droite	AF220005045	AF220005079
		Porte gauche	AF220014524	AF220014544
56	Support gache		AF220005469	AF220005469
57	Gache		AF220001079	AF220001079
58	Boîte buée	Porte droite	AF220005436	AF220005436
		Porte gauche	AF220014530	AF220014530
59	Fronton monté	Porte droite	AF220005147	AF220005139
		Porte gauche	AF220014526	AF220014546
60	Support crochet	Porte droite	AF220005403	AF220005403
		Porte gauche	AF220014585	AF220014585
61	Crochet	Porte droite	AF220005402	AF220005402
		Porte gauche	AF220014538	AF220014538
62	Bague axe		AF220005401	AF220005401
63	Circlips		AF200032900	AF200032900
64	Ressort		AF200037615	AF200037615
65	Câble		AF220005496	AF220005496
66	Serre Câble		AF220005497	AF220005497
67	Rondelle isolation		AF220005024	AF220005024
68	Cadre extérieur porte	Porte droite	AF220005431	AF220005430
		Porte gauche	AF220014532	AF220014552

8.10. ELECTRIC HEATING UNIT

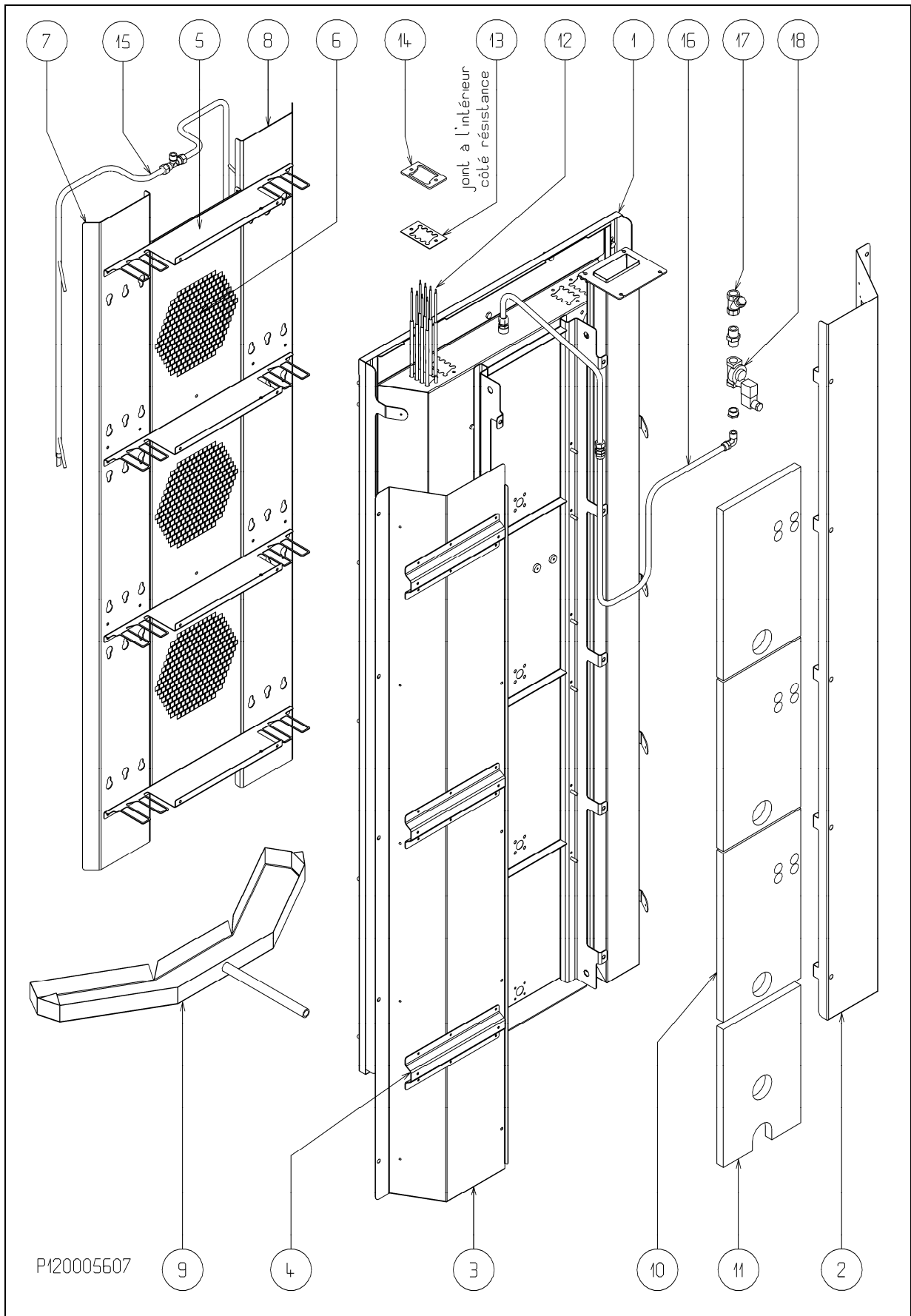

Electric heating unit

Rep.	Désignation		M1	M2
	BLOC MONTE ELECTRIQUE	50Hz	AF220005607	AF220005608
		60Hz	AF220006650	AF220006651
	Planche 1			
	COMPRENANT			
1	Bloc soudé		AF220005191	AF220005134
2	Tôle isolation droite		AF220005178	AF220005113
3	Tôle isolation gauche (coffret)		AF220005177	AF220005112
4	Traverse support coffret		AF220005236	AF220005236
5	Cloison horizontale intérieure		AF220005180	AF220005116
6	Tôle centrale aspiration	50Hz	AF220005179	AF220005114
		60Hz	AF220006640	AF220006641
7 - 8	Volet aspiration		AF220006504	AF220006509
9	Boîte trop plein	AF220006532 -> SEP 2002	AF220006533 -> SEP 2002	
		AF220005675 -> OCT 2002	AF220005676 -> OCT 2002	
10	Isolation arrière haute		AF220005028	AF220005266
11	Isolation arrière basse		AF220005029	AF220005267
12	Bloc résistance		AF220005014	AF220005010
13	Joint résistance		AF220005023	AF220005023
14	Bride résistance		AF220005182	AF220005182
15	Ensemble sortie eau		AF220006550	AF220006551
16	Ensemble alimentation eau		AF220005680	AF220005680
17	Filtre		AF200031385	AF200031385
18	Electrovanne		AF220006915	AF220006915

8.11. OIL/GAS HEATING UNIT PARTS LIST

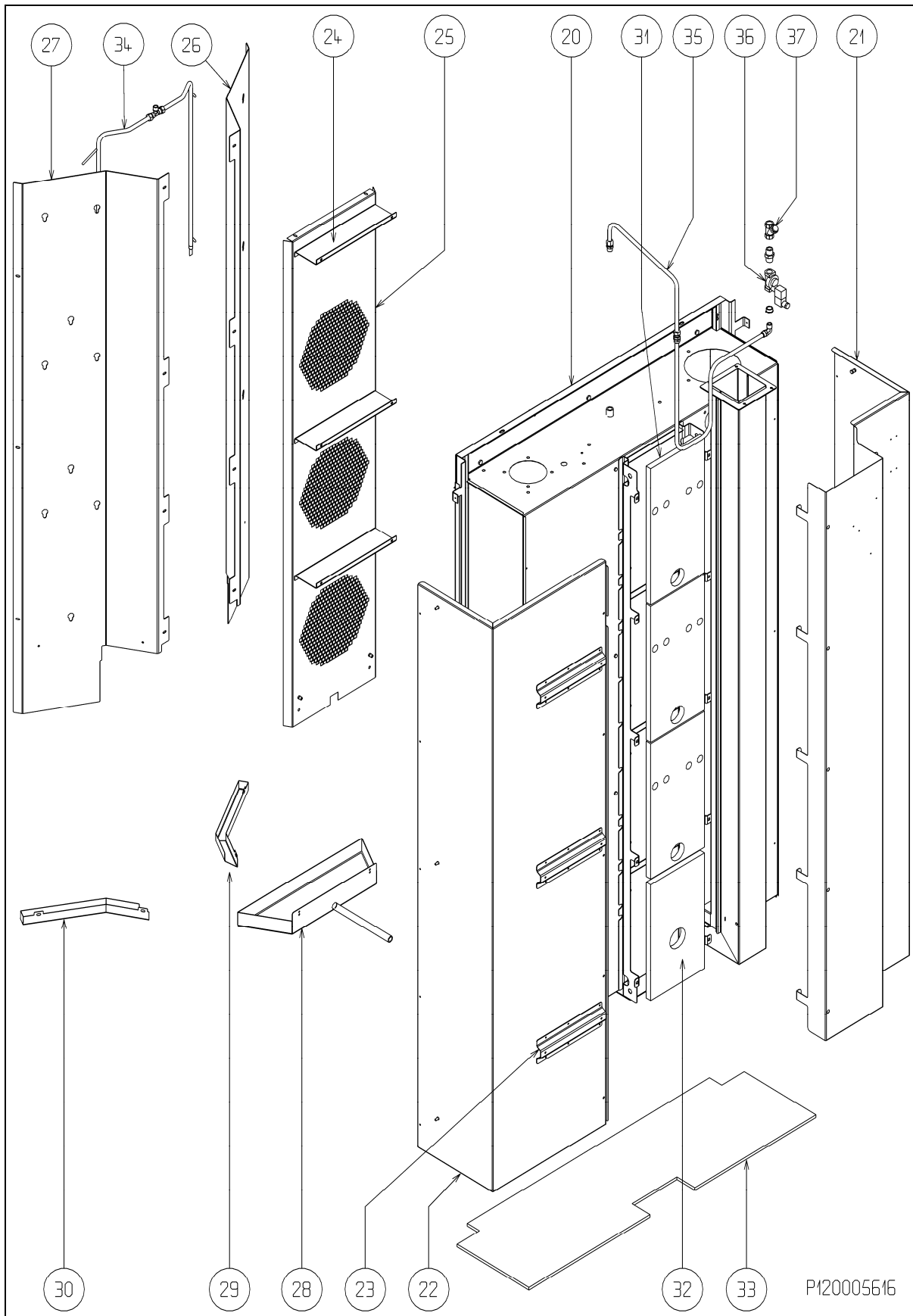

Oil/Gas Heating unit parts list

Rep.	Désignation		M1	M2
	BLOC MONTE MAZOUT/GAZ	50Hz	AF220005615	AF220005616
		60Hz	AF220006655	AF220006656
20	Bloc soudé		AF220005355	AF220005136
21	Tôle isolation droite		AF220005535	AF220005537
22	Tôle isolation gauche		AF220005536	AF220005538
23	Traverse support coffret		AF220005236	AF220005236
24	Séparation horizontale		AF220005327	AF220005371
25	Tôle centrale aspiration	50Hz	AF220005359	AF220005501
		60Hz	AF220006665	AF220006666
26	Volet gauche aspiration		AF220006518	AF220006520
27	Volet droit aspiration		AF220006519	AF220006521
28	Boîte trop plein		AF220005677	AF220005678
29	Bac gauche		AF220006660	AF220006662
30	Bac droit		AF220006661	AF220006663
31	Isolation arrière haute		AF220005028	AF220005268
32	Isolation arrière basse		AF220005029	AF220005269
33	Isolation inférieure		AF220005575	AF220005576
34	Ensemble sortie eau M/G		AF220006552	AF220006553
35	Ensemble alimentation eau		AF220005680	AF220005680
	Raccord		AF200031461	AF200031461
36	Electrovanne		AF220006915	AF220006915
37	Filtre		AF200031385	AF200031385

8.12. HEATING UNIT PARTS LIST: MOTOR IMPELLER ASSEMBLY

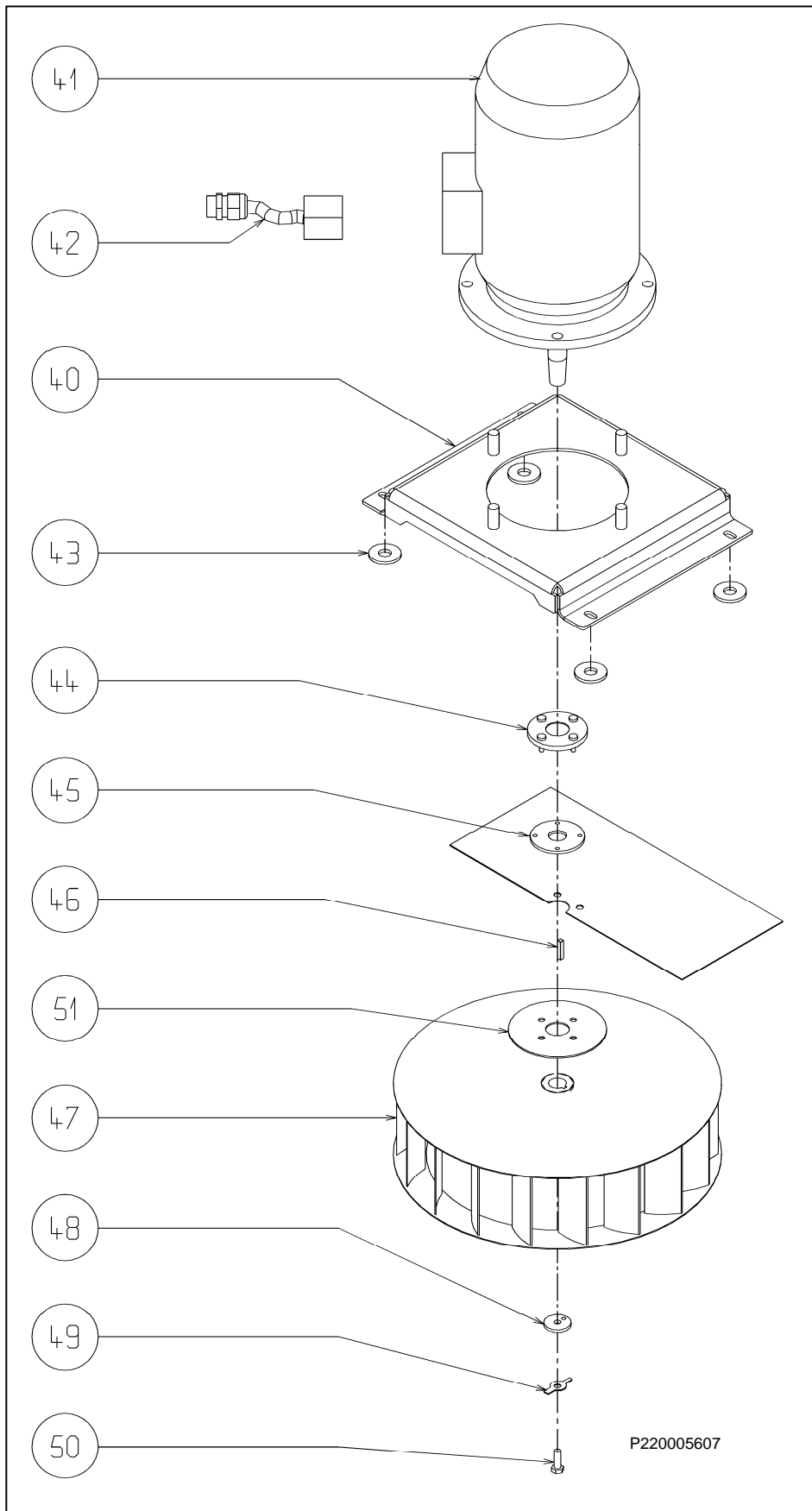

Heating unit parts list: motor-impeller

Rep.	Désignation		M1	M2
40	Support moteur		AF220005235	AF220005235
41	Moteur	50 Hz	AF200033941	AF200033942
		60 Hz	AF200033942	AF200033943
42	Connecteur		AF220005728	AF220005728
43	Rondelle isolante		AF200001473	AF200001473
44	Rondelle étanchéité		AF220008228	AF220008228
45	Joint étanchéité		AF200012539	AF200012539
46	Clavette		AF200019129	AF200019129
47	Turbine		AF220001192	AF220005270
48	Rondelle arrêt		AF201923301	AF201923301
49	Plaquette arrêt		AF201913001	AF201913001
50	Vis arrêt		AF200032003	AF200032003
51	Rondelle renfort joint moteur		AF220004625	AF220004625

8.13. DAMPER PARTS LIST

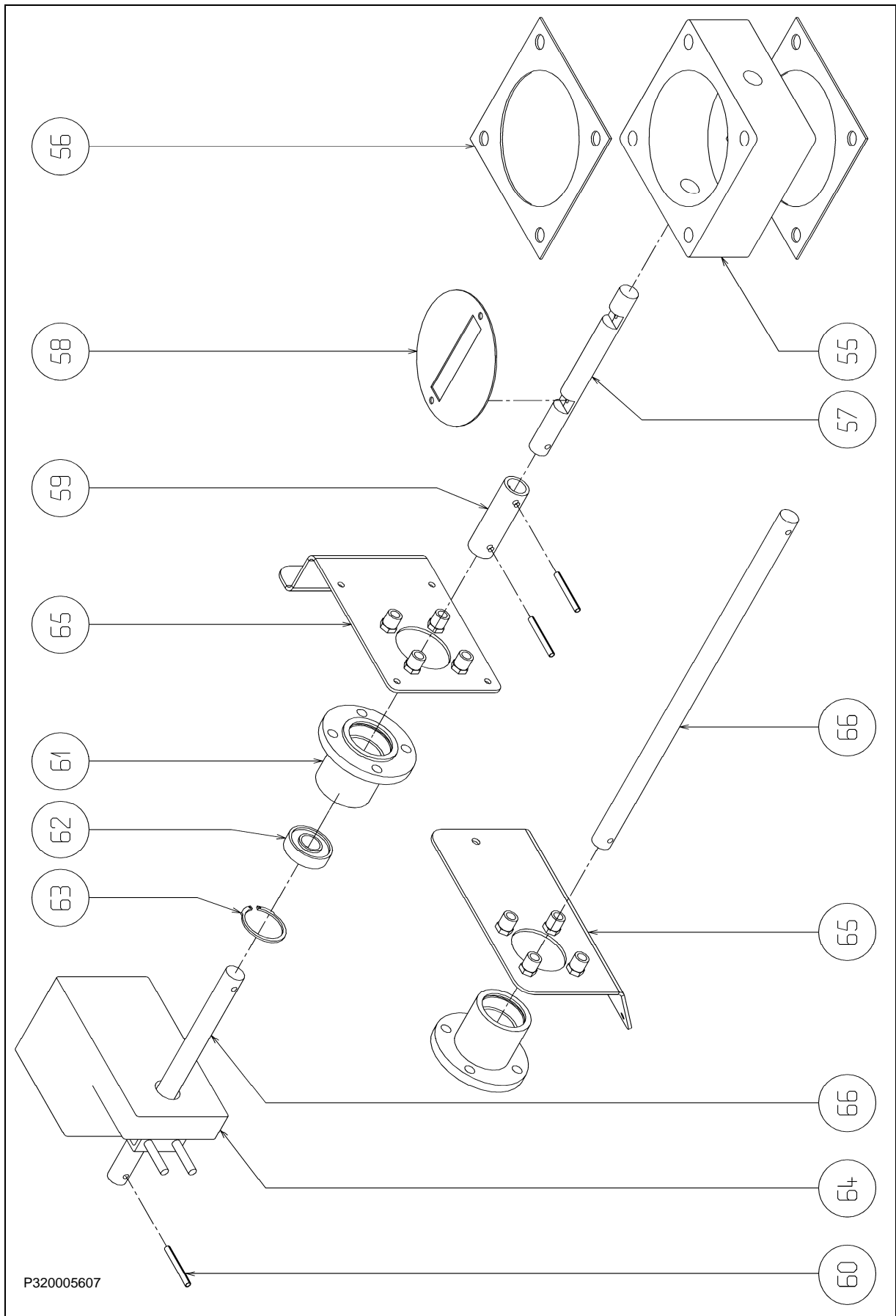

Damper parts list

Rep.	Désignation		M1	M2
55	Corps		AF220005039	AF220005039
56	Joint		AF220005030	AF220005030
57	Axe		AF220005488	AF220005488
58	Volet		AF220005291	AF220005291
59	Cardan		AF220005225	AF220005225
60	Goupille		AF200032598	AF200032598
61	Palier commande		AF220005489	AF220005489
62	Roulement à billes		2x AF200033090	2x AF200033090
63	Circlips		AF200032896	AF200032896
64	Servo-moteur		AF220005571	AF220005571
65	Support moteur	électrique	AF220005590	AF220005590
		mazout/gaz	AF220005591	AF220005591
66	Axe commande	électrique	AF220005494	AF220005494
		mazout/gaz	AF220005495	AF220005495

8.14. HEAT EXCHANGER PARTS LIST

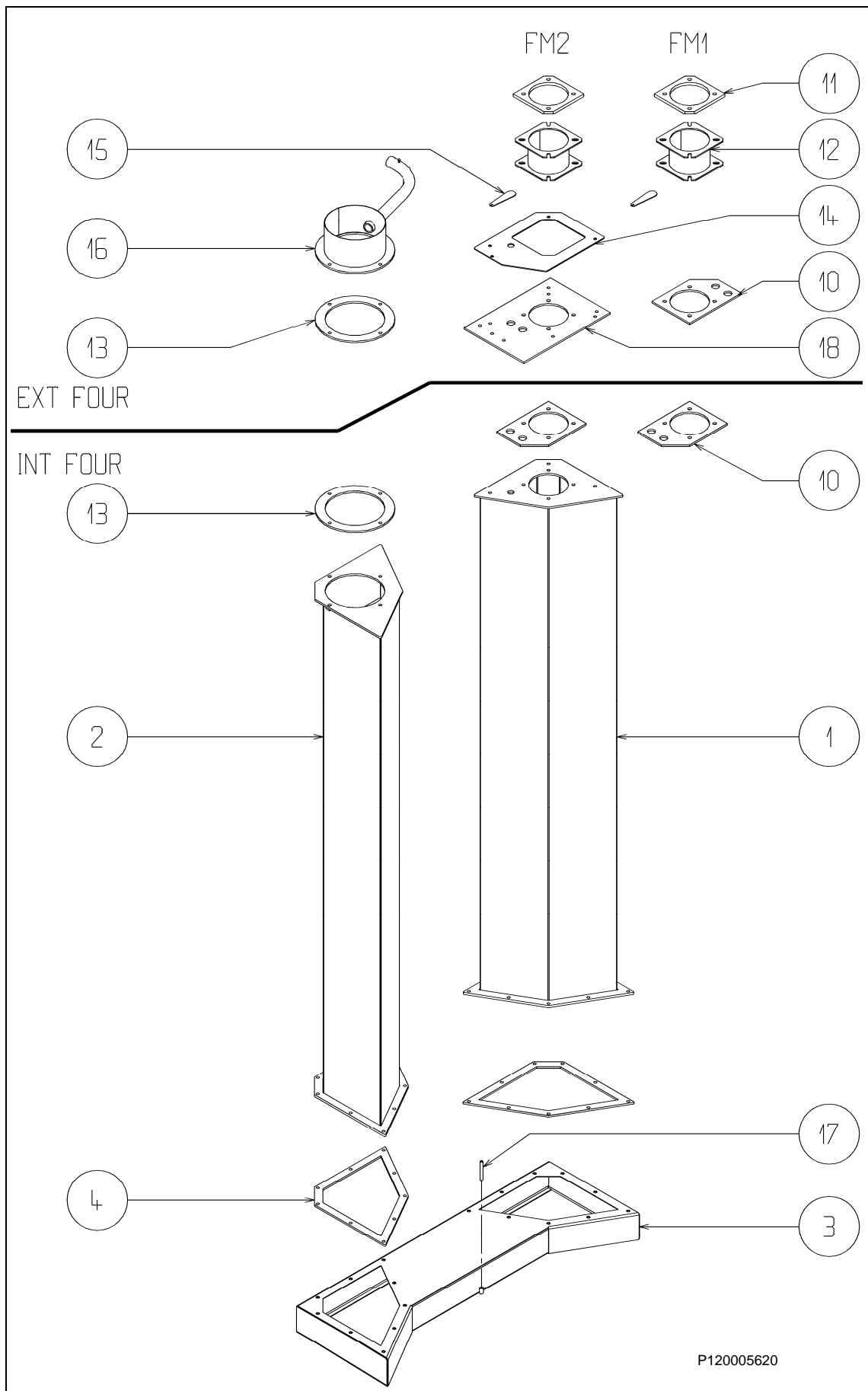

Oil/gas heat exchanger parts list

Rep.	Désignation	M1	M2
	ECHANGEUR MONTE	AF220005619	AF220005620
	COMPRENANT		
1	Colonne brûleur	AF220005352	AF220005541
2	Colonne cheminée	AF220005353	AF220005542
3	Boîte inférieure	AF220005354	AF220005543
4	Joint bride basse	AF220005520	AF220005521
10	Joint bouchon sup. brûleur	AF220005526	AF220005526
11	Isolant brûleur	AF220005272	AF220005272
12	Support brûleur H90	AF220005350	AF220005350
	Support brûleur H50	AF220005566	AF220005566
13	Joint bouchon sup. sortie	AF220005523	AF220005524
14	Renfort support colonne	-	AF220005379
15	Œillette	AF220005449	AF220005449
16	Sortie fumée	AF220005683	AF220005684
17	Axe guide échangeur	AF220005358	AF220005358
18	Joint bouchon sup brûleur	-	AF220017591

- Parts no. 4,10,13 and 18 are made of 6 mm thick high-temperature fibre. (not compressed).

- Part no. 11 is made of 10 mm thick high-temperature fibre (not compressed).

8.15. INCLINED PAN PARTS LIST

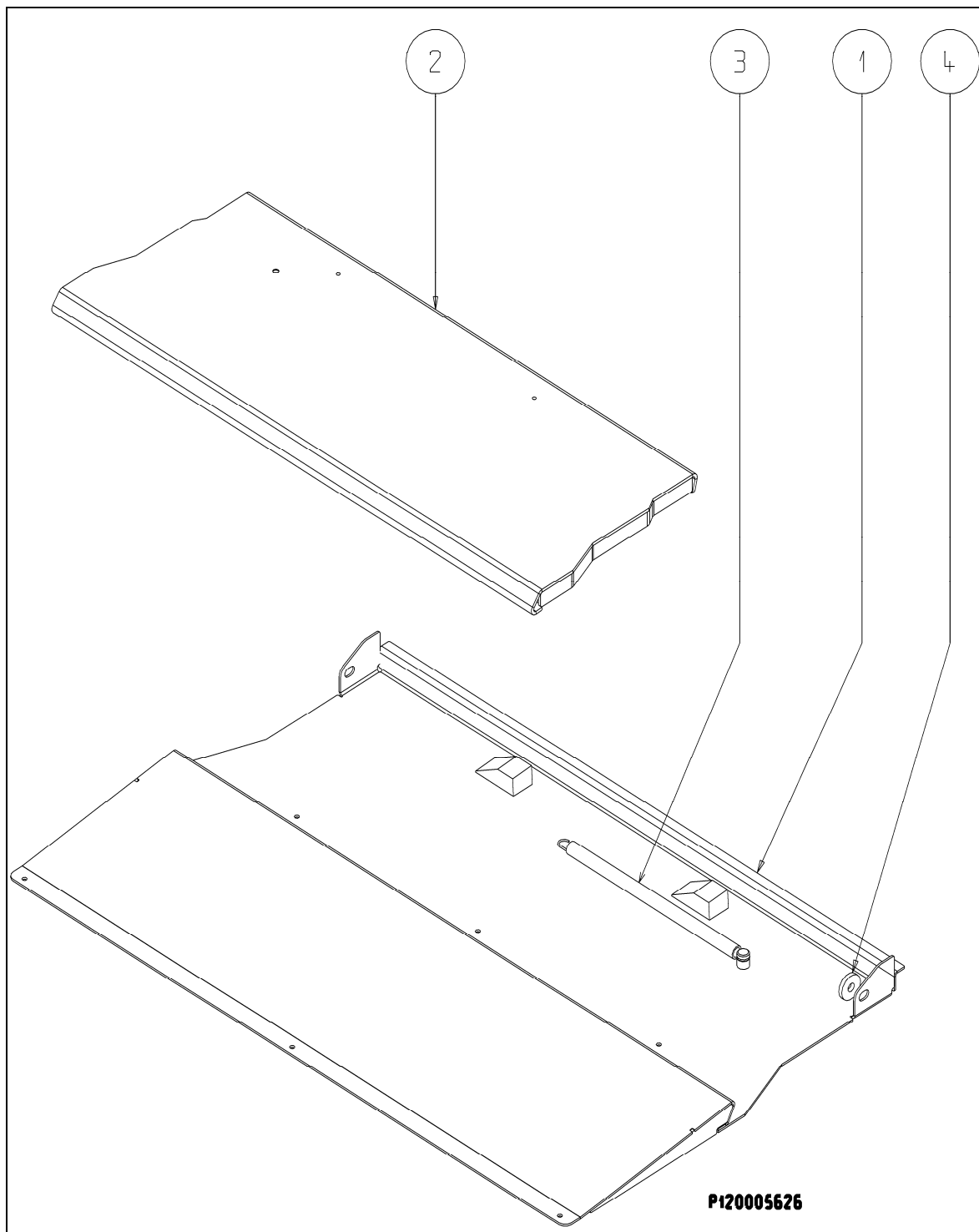

Inclined pan parts list

Rep.	Désignation		M1	M2
	PAN INCLINE MONTE	Porte droite	AF220005626	AF220005627
		Porte gauche	AF220014500	AF220014506
	COMPRENANT			
1	Pan incliné fixe	Porte droite	AF220005640	AF220005642
		Porte gauche	AF220014503	AF220014509
2	Pan incliné mobile	Porte droite	AF220005641	AF220005643
		Porte gauche	AF220014501	AF220014507
3	Ressort de rappel		AF220005499	AF220005499
4	Rondelle de calage		AF220014609	AF220014609

8.16. STEAM EXHAUST FAN PARTS LIST

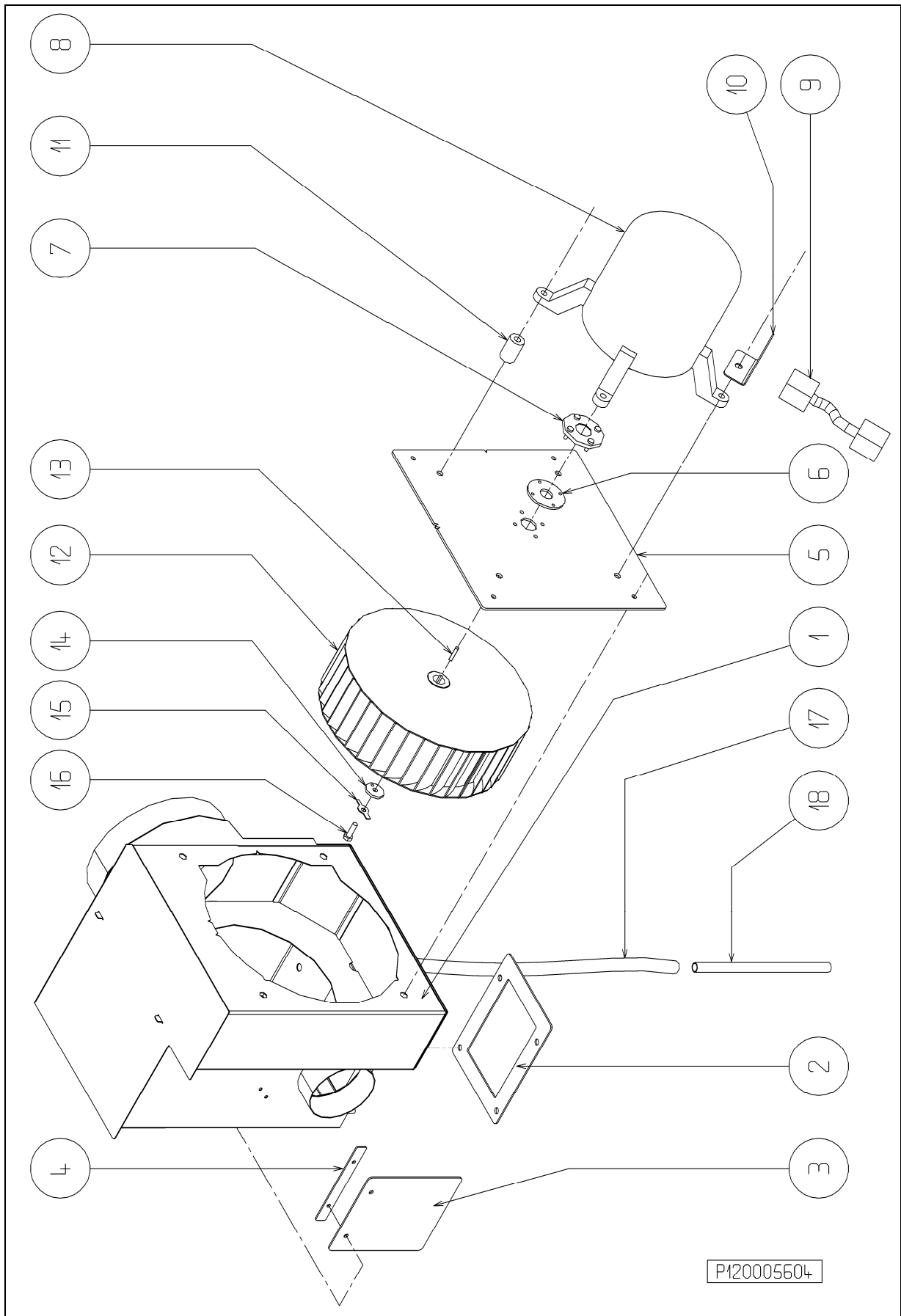

Steam exhaust fan parts list

Rep.	Désignation	M1	M2	S.A.V.
	EXTRACTEUR MONTE	AF220005604	AF220005605 →10/00 →11/00 AF220006670	
	COMPRENANT			
1	Boîte extracteur	AF220005464	AF220005465	
2	Joint	AF220005263	AF220005263 →10/00 →11/00 AF220006675	
3	Clapet	AF220005264	AF220005264	x
4	Support clapet	AF220005457	AF220005457	
5	Support moteur	AF220005453	AF220005453	
6	Joint étanchéité	AF200012539	AF200012539	x
7	Rondelle étanchéité	AF220008228	AF220008228	
8	Moteur	AF200033940	AF200033940	x
9	Rallonge connecteur	AF220005722	AF220005722	
10	Patte rallonge connecteur	AF220005458	AF220005458	x
11	Entretoise support moteur	AF220005498	AF220005498	
12	Turbine	AF220005417	AF220005417	x
13	Clavette	AF200019129	AF200019129	x
14	Rondelle arrêt	AF201923301	AF201923301	x
15	Plaquette arrêt	AF201913001	AF201913001	x
16	Vis arrêt	AF200032003	AF200032003	x
17	Tube cristal lg 2m	AF200021488	AF200021488	
18	Tube cuivre	AF220005529	AF220005529	

8.17. SQUIRREL CAGE PARTS LIST

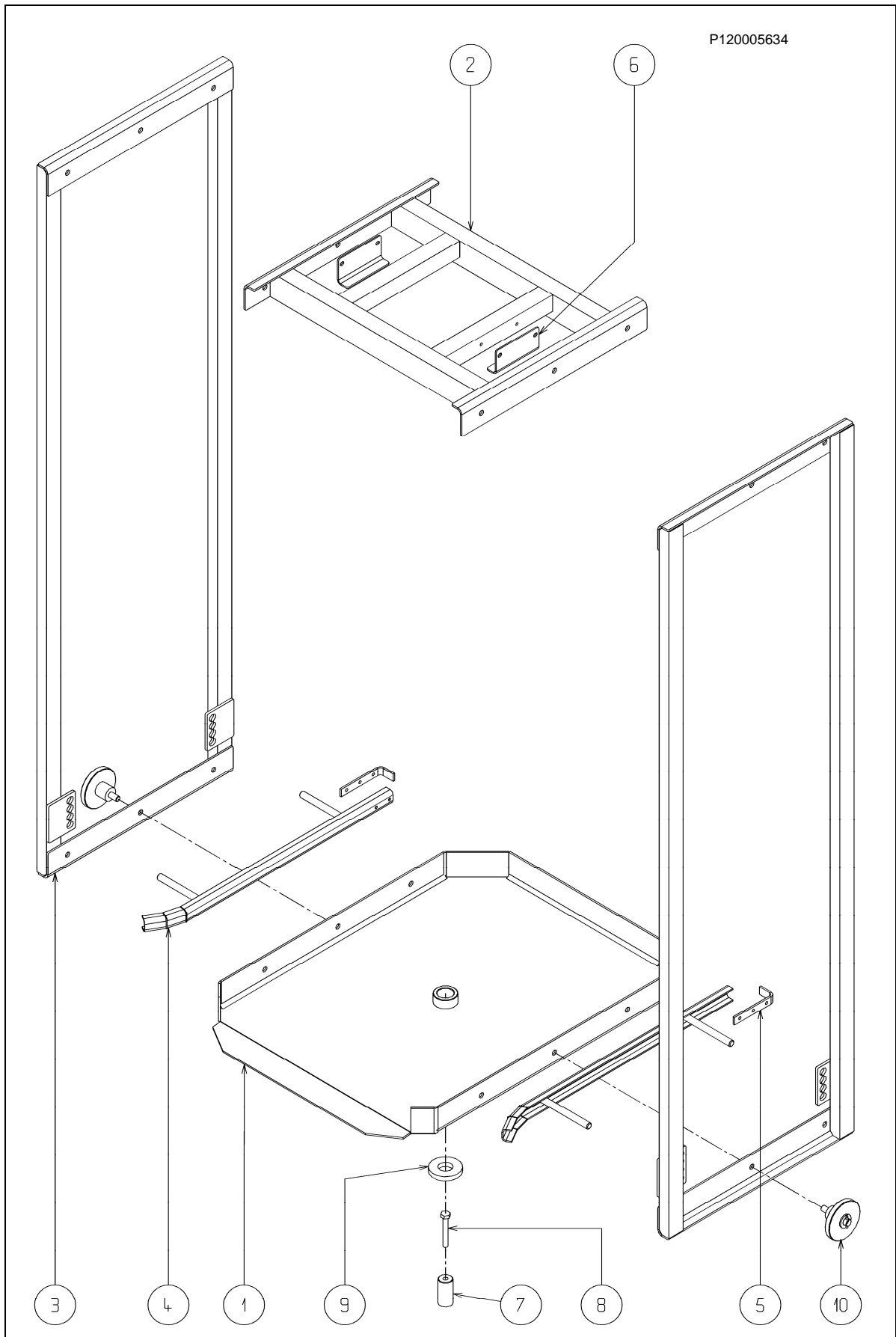

Squirrel cage parts list

Rep.	Désignation	M1	M2
	CAGE D'ECUREUIL	AF220005634	AF220005635
	COMPRENANT		
1	Plateau soudé	AF220005195	AF220005100
2	Chassis soudé	AF220005196	AF220005102
3	Montant soudé	AF220005138	AF220005101
4	Glissière latérale soudé	AF220005651	AF220005651
5	Butée arrière	AF220005254	AF220005254
6	Cornière extérieure disque	AF220005097	AF220005097
7	Centreur	AF220005018	AF220005018
8	Vis 10x80	AF200032255	AF200032255
9	Bague inférieure	AF220006557	AF220006557
10	Axe roulette montée	AF220006560	AF220006560

8.18. CONTROL PANEL PARTS LIST

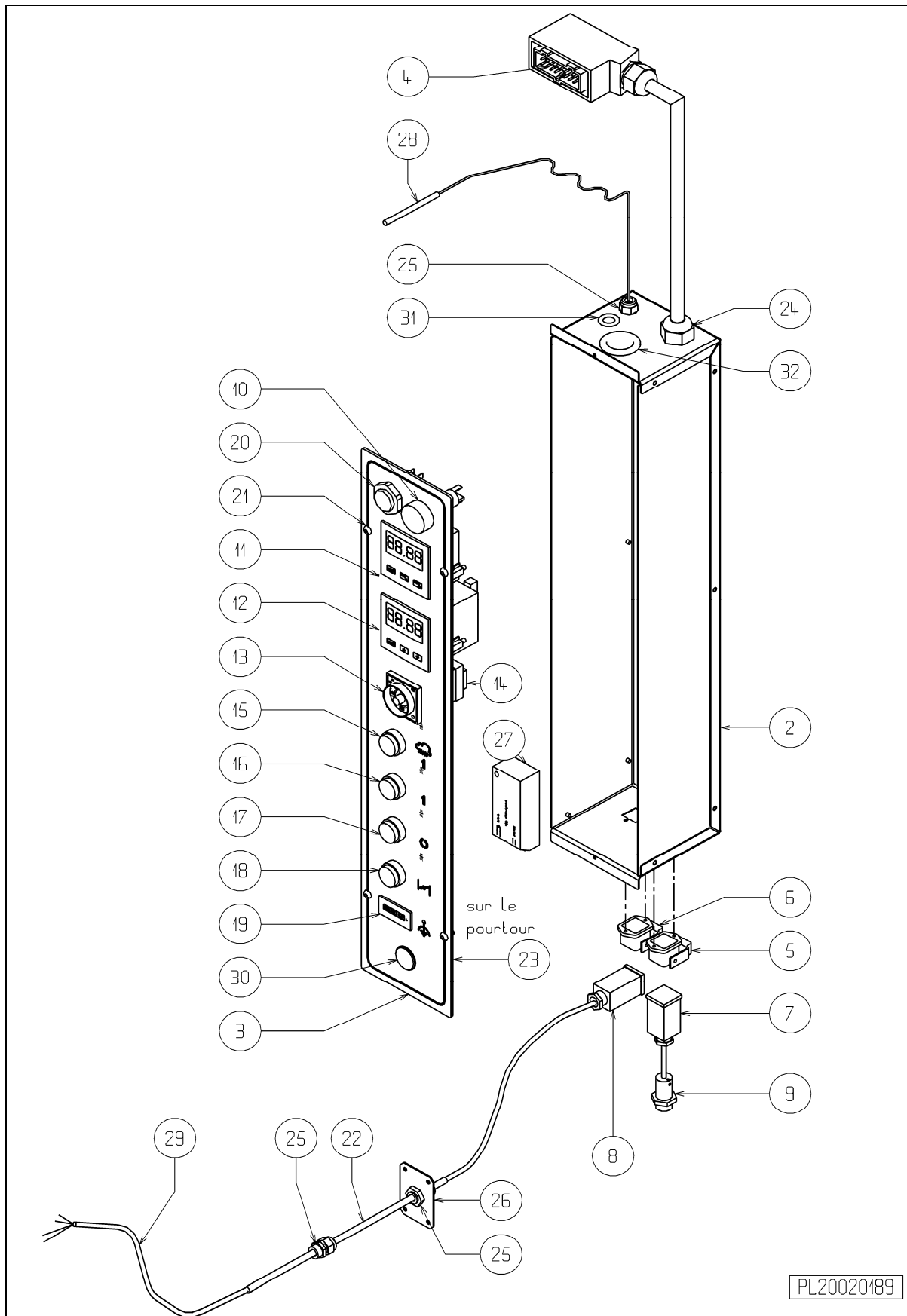

Control panel parts list

Rep.	Désignation	M1	M2
2	Boîte brute assemblée	AF220007411	AF220007411
3	Face avant sérigraphiée	AF220005477	AF220005477
4	Connecteur façade câblé	AF220005713	AF220005713
5	Embase 3-4 plots + T 10 A Insert femelle 4 pôles + T 10 A	AF200033781 AF200033784	AF200033781 AF200033784
6	Embase 3-4 plots + T 10 A Insert mâle 4 pôles + T 10 A	AF200033781 AF200033783	AF200033781 AF200033783
7	Capot 3-4 plots + T 10 A Insert mâle 4 pôles + T 10 A	AF200033782 AF200033783	AF200033782 AF200033783
8	Capot 3-4 plots + T 10 A Insert femelle 4 pôles + T 10 A	AF200033782 AF200033784	AF200033782 AF200033784
9	Detector inductif D18 5mm	AF200033793	AF200033793
10	Voyant D22 IP65 Jaune	AF270033003	AF270033003
11	Ancienne horloge différé cuisson ->10.2007 Nouvelle horloge différé cuisson 10.2007->	AF200033802 AF270026001	AF200033802 AF270026001
12	Ancien régulateur température ->10.2007 Nouveau régulateur température 10.2007->	AF200033785 AF270024001	AF200033785 AF270024001
13	Minuterie 48 x 48 220V Capot protection minuterie 48x48	AF200033676 AF200033678	AF200033676 AF200033678
14	Socle minuterie 48x48 Fixation minuterie	AF200033677 AF200033712	AF200033677 AF200033712
15	Tête lumineuse impulsion verte dépassant Embase bloc électrique Bloc contact F à vis standard Bloc lumineux vert 230V	AF200033831 AF200033837 AF200033841 AF200033838	AF200033831 AF200033837 AF200033841 AF200033838
16	Tête lumineuse impulsion verte dépassant Embase bloc électrique Bloc contact F à vis standard Bloc lumineux vert 230V	AF200033831 AF200033837 AF200033841 AF200033838	AF200033831 AF200033837 AF200033841 AF200033838
17	Tête impulsion rouge dépassant Embase bloc électrique Bloc contact O à vis standard	AF200033830 AF200033837 AF200033840	AF200033830 AF200033837 AF200033840

Control panel parts list (continued)

Rep.	Désignation	M1	M2	
18	Tête lumineuse impulsion verte dépassant	AF200033831	AF200033831	
	Embase bloc électrique	AF200033837	AF200033837	
	Bloc contact F à vis standard	AF200033841	AF200033841	
	Bloc lumineux vert 230V	AF200033838	AF200033838	
19	Compteur horaire 208/230V	50Hz	AF200033774	33774
		60Hz	AF200033775	33775
20	Buzzer 90D 230V	AF200033803	AF200033803	
21	Vis inox TB HC 6 x 12	AF200032094	AF200032094	
22	Gaine inox Ø6,6 x 8,2	AF220005282	AF220005282	
23	Joint 10 x 3 autocollant	AF220005290	AF220005290	
24	Presse étoupe plastique 21	AF200033058	AF200033058	
	Contre écrou plastique 21	AF200033059	AF200033059	
25	Presse étoupe plastique 9	AF200033776	AF200033776	
	Contre écrou plastique 9	AF200033777	AF200033777	
26	Rivet à deux clips de masse	AF220005230	AF220005230	
27	Transfo d'eclairage 03.2007 →	AF200033617	AF200033617	
	Ancien starter →03.2007	AF200033354	AF200033354	
28	Thermocouple J Lg = 4500	AF200033791	AF200033791	
29	Câble 5 x 0,75 MTP Lg = 3200	AF220005705	AF220005705	
30	Bouchon D 22	AF200033507	AF200033507	
31	Passe fil D 13.5	AF200033596	AF200033596	
32	Passe fil D 29	AF200033479	AF200033479	

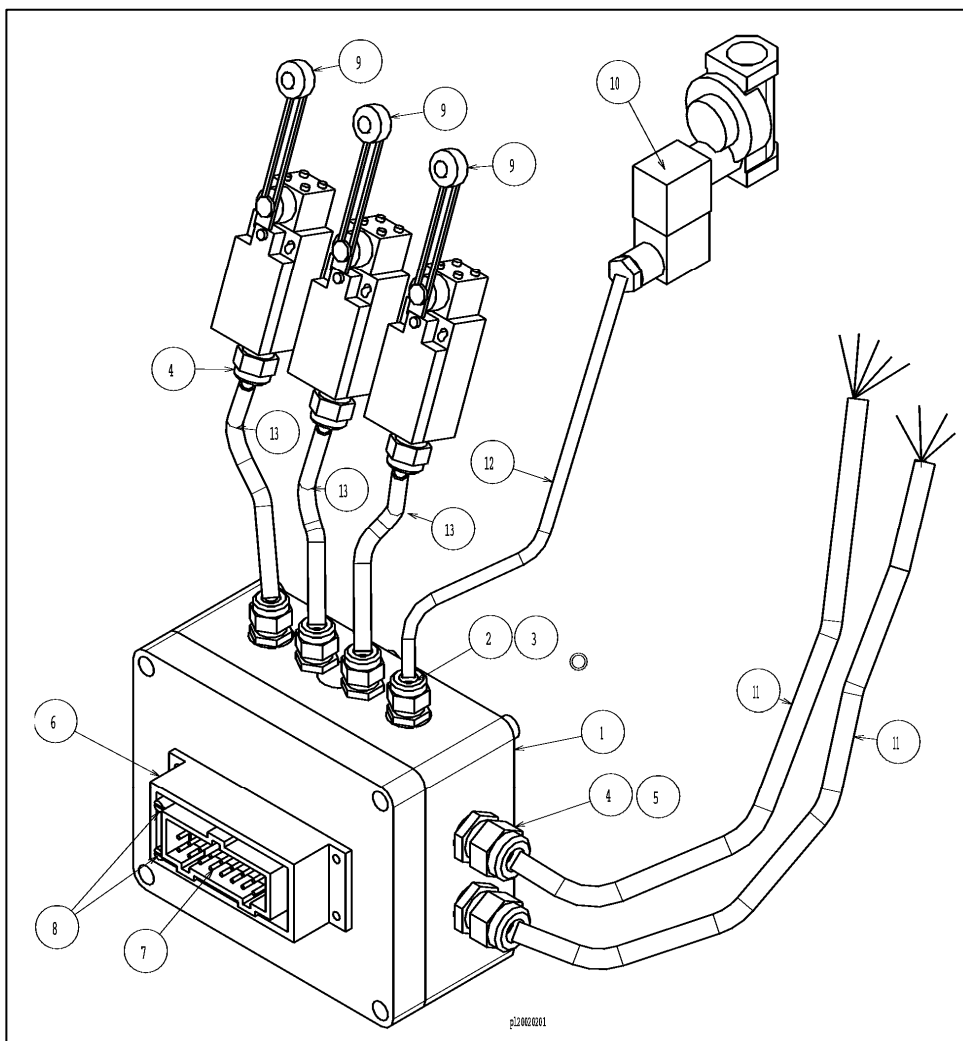
8.19. ROOF DISTRIBUTION BOX PARTS LIST**Roof distribution box parts list**

Rep.	Désignation	Code	S.A.V.
1	Boîte de dérivation percée	AF220005700	
2	Presse étoupe plastique 9	AF200033776	
3	Contre écrou plastique 9	AF200033777	
4	Presse étoupe plastique 13	AF200030199	
5	Contre écrou plastique 13	AF200033195	
6	Embase fixation 16 plots	AF200033283	
7	Isolant mâle 16 plots 16A	AF200033285	
8	Vis de détrompage connecteur	AF200033773	
9	Détecteur plastique à galet	AF200033790	x
10	Electrovanne 230V 50/60 Hz	AF220006915	x
11	Câble 7 x 1 caoutchouc siliconé Lg=2000	AF220005702	
12	Câble 3 x 1 caoutchouc siliconé Lg=2000	AF220005703	
13	Câble 3 x 1 caoutchouc siliconé Lg=1000	AF220005704	

8.20. OIL/GAS 380/415V ELECTRICAL CABINET BACK PARTS LIST

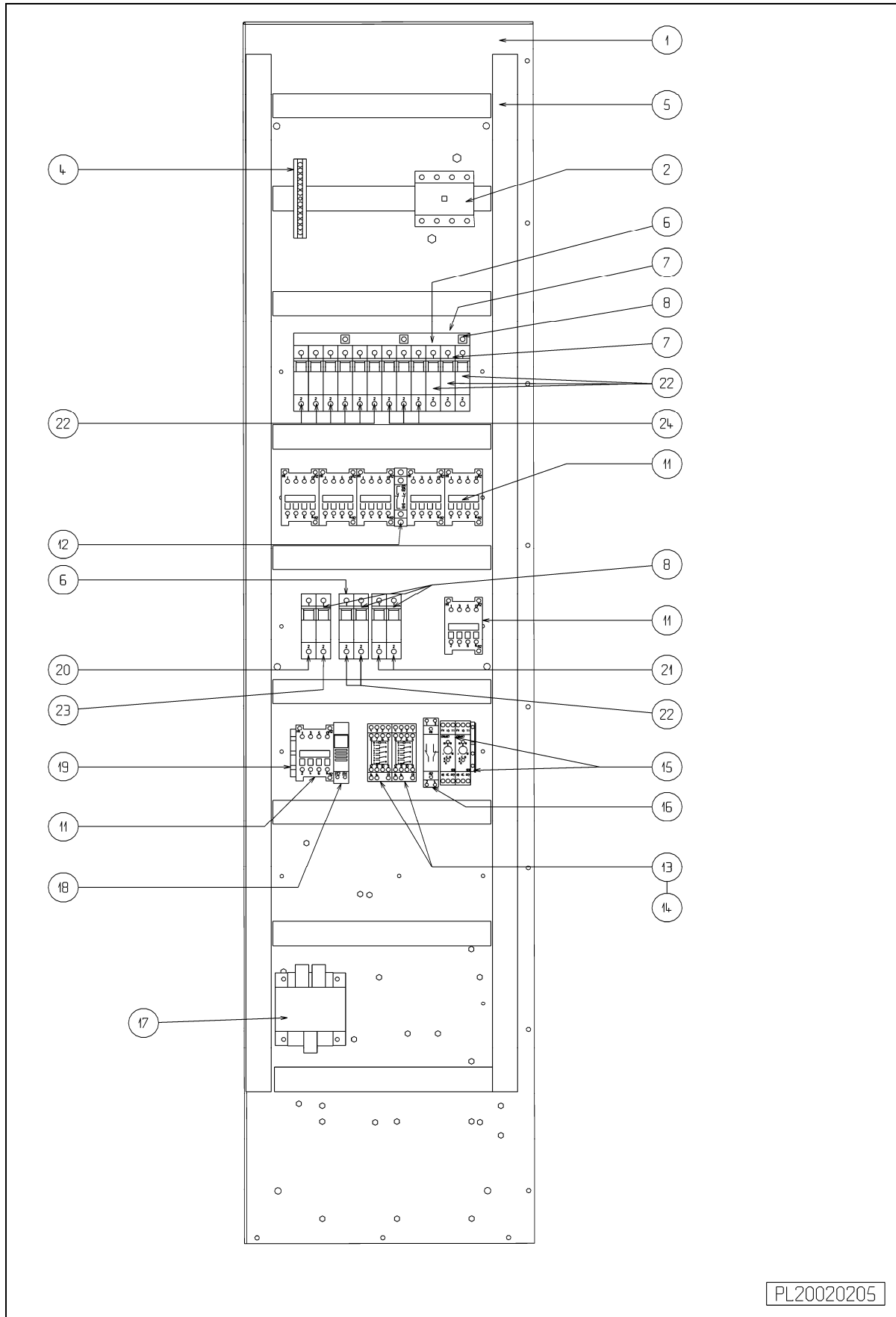

PL20020205

Oil/gas 380/415v electrical cabinet back parts list

Rep.	Désignation	380/415V	S.A.V.
1	Fond coffret M1	AF220005492	
2	Inter sectionneur tetra 32A	AF200033483	
4	Bornier vert 12 plots	AF200033797	
5	Goulotte de câblage	AF200033005	
6	Porte fusible 10,3 x 38	AF200033502	
7	Kit d'association 3 pôles	AF200033218	
8	Kit d'association 2 pôles	AF200033215	
9	Barre de pontage tri 4 appareils	AF200033799	
10	Borne de raccordement	AF200033798	
11	Contacteur triphasé 25A 230V	AF270010100	x
12	Adjonction inverseur électrique	AF270012000	
13	Socle relai 4 RT	AF200033711	
14	Relai 4 RT 10A 230V	AF200033586	x
15	Temporisation fond armoire Multigamme	AF200033674	x
16	Télérupteur 230V bipolaire inverseur	AF200033440	x
17	Transformateur mono 130VA 400/230V	AF200033770	
18	Sonnerie modulaire 230V	AF200033374	
19	Borne 6 mm(r) vert jaune	AF200030274	
20	Fusible 10 x 38 neutre	AF200033187	
21	Fusible 10 x 38 1A gi	AF200033203	x
22	Fusible 10 x 38 2A am	AF200033722	x
23	Fusible 10 x 38 4A am	AF200033143	x
24	Fusible 10 x 38 8A am	AF200030523	x
25	Transformateur mono 130VA	AF270010503	

8.21. OIL/GAS 208/230V ELECTRICAL CABINET BACK PARTS LIST

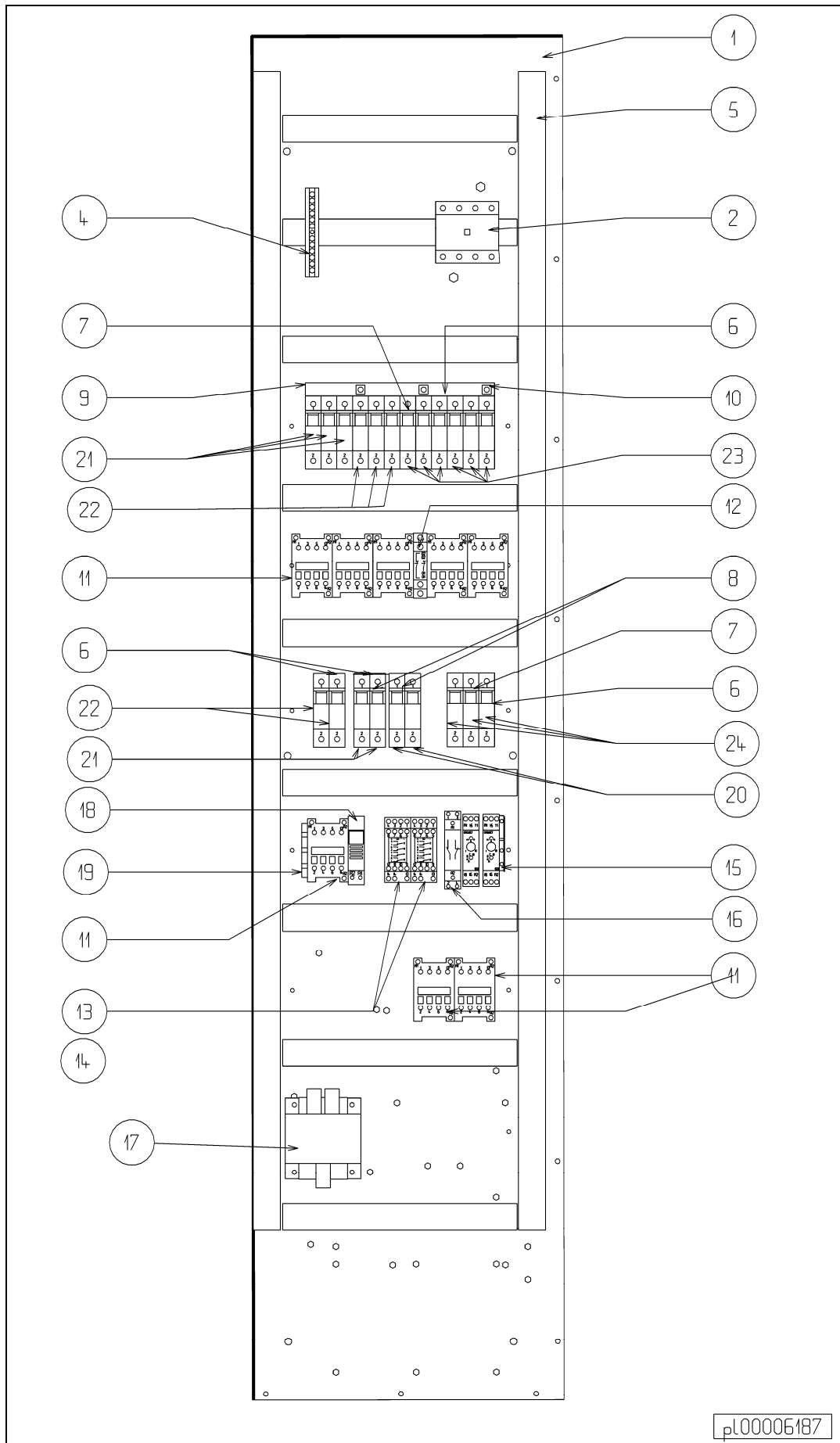

pL00006487

Oil/gas 208/230v electrical cabinet back parts list

Rep.	Désignation	208/230V	S.A.V.
1	Fond coffret M1	AF220005492	
2	Inter sectionneur tetra 32A	AF200033483	
4	Bornier vert 12 plots	AF200033797	
5	Goulotte de câblage	AF200033005	
6	Porte fusible 10,3 x 38	AF200033502	
7	Kit d'association 3 pôles	AF200033218	
8	Kit d'association 2 pôles	AF200033215	
9	Barre de pontage tri 4 appareils	AF200033799	
10	Borne de raccordement	AF200033798	
11	Contacteur triphasé 25A 230V	AF270010100	x
12	Adjonction inverseur électrique	AF270012000	
13	Socle relai 4 RT	AF200033711	
14	Relai 4 RT 10A 230V	AF200033586	x
15	Temporisation fond armoire Multigamme	AF200033674	x
16	Télerupteur 230V bipolaire inverseur	AF200033440	x
17	Transformateur mono 130VA	AF270010503	
18	Sonnerie modulaire 230V	AF200033374	
19	Borne 6 mm(r) vert jaune	AF200030274	
20	Fusible 10 x 38 1A gi	AF200033203	x
21	Fusible 10 x 38 2A am	AF200033722	x
22	Fusible 10 x 38 4A am	AF200033143	x
23	Fusible 10 x 38 8A am	AF200030523	x

8.22. OIL/GAS ELECTRICAL CABINET PARTS LIST

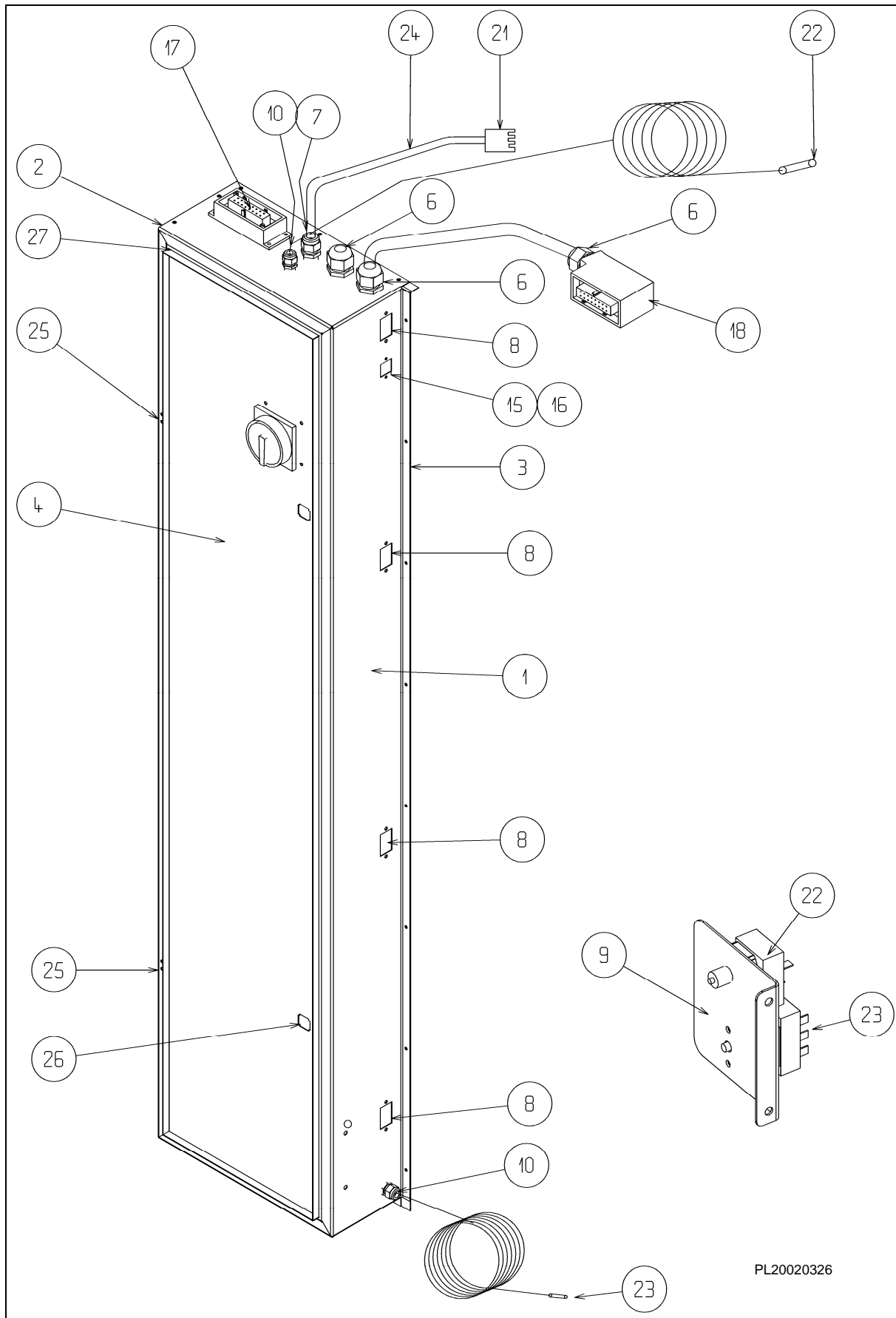

Oil/gas electrical cabinet parts list

Rep.	Désignation	Code	S.A.V.
1	Côté droit coffret	AF220005567	
2	Côté gauche coffret	AF220005490	
3	Fond monté	AF220005739	
4	Porte coffret	AF220005493	
6	Presse étoupe 21 plastique contre écrou 21 plastique	AF200033058 AF200033059	
7	Presse étoupe 13 plastique contre écrou 13 plastique	AF200030199 AF200033195	
8	Connecteurs moteur câblés 380V Connecteurs moteur câblés 230V	AF220005709 AF220005770	
9	Support thermostat	AF220005595	
10	Presse étoupe 9 plastique contre écrou 9 plastique	AF200033776 AF200033777	
15	Embase 3-4 pôles + terre 10A	AF200033781	
16	Insert femelle 4 pôles + terre	AF200033784	
17	Connecteur câblé 1mm ² 16 plots	AF220005710	
18	Connecteur 16 plots coffret plafond	AF220005714	
21	Fiche mâle 6 x 2,5 mm ²	AF200033377	
22	Thermostat de sécurité 100°C	AF200033779	x
23	Thermostat de sécurité 340)C	AF200033362	x
24	Câble 4 x 1 caoutchouc siliconé Lg = 2500	AF220005717	
25	Charnière de porte	AF220005262	
26	1/4 de tour serrure	AF220005265	
27	Joint de porte	AF220005290	

8.23. ELECTRIC M1E 380/415V ELECTRICAL CABINET BACK PARTS LIST

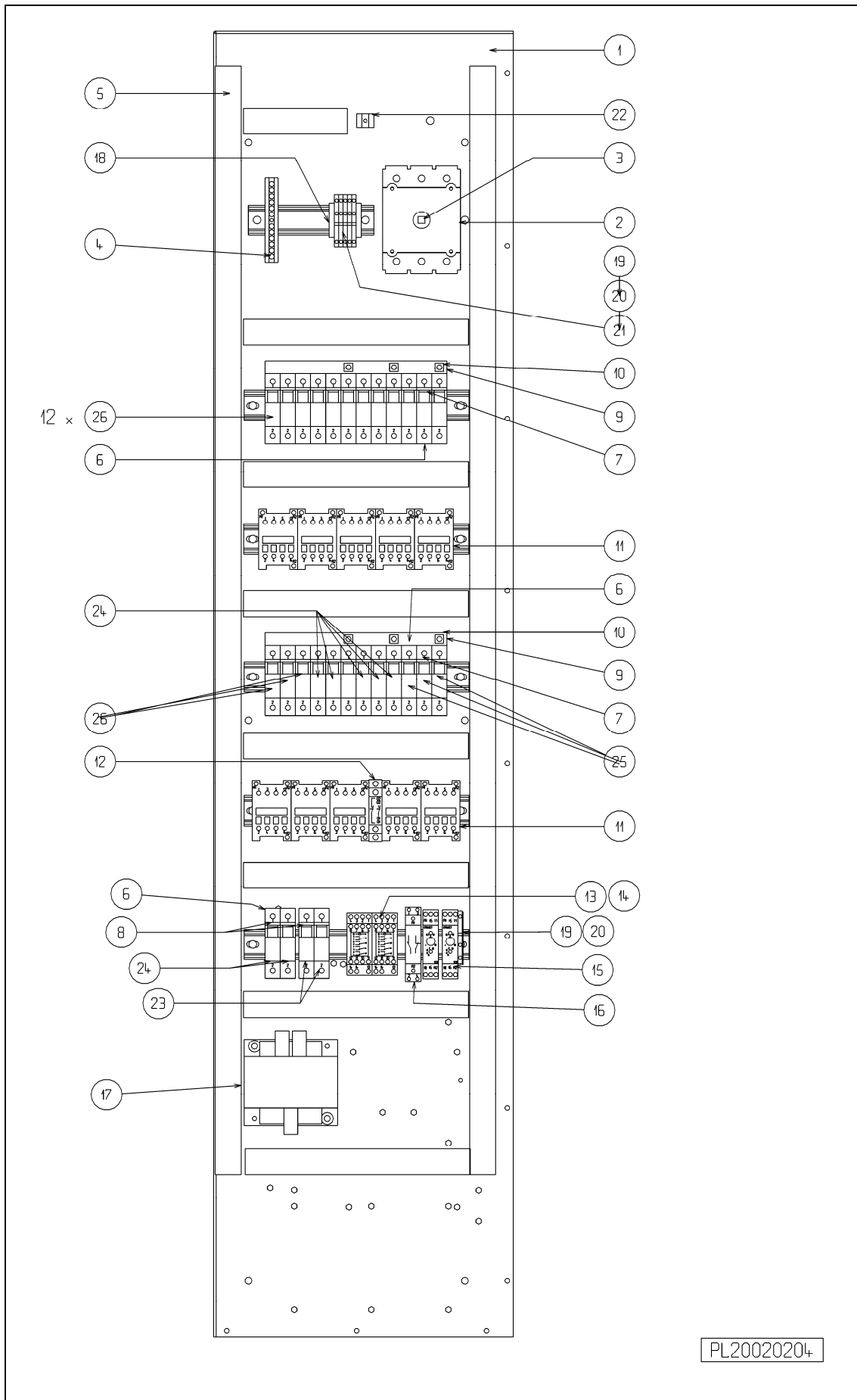

PL20020204

Electric M1 380/415V electrical cabinet back parts list

Rep.	Désignation	380/415V	S.A.V.
1	Fond coffret	AF220005492	
2	Inter sectionneur tri 125A	AF200033741	
3	Rallonge d'axe	AF200033576	
4	Bornier vert 12 plots	AF200033797	
5	Goulotte de câblage	AF200033005	
6	Porte fusible 10,3 x 38	AF200033502	
7	Kit d'association 3 pôles	AF200033218	
8	Kit d'association 2 pôles	AF200033215	
9	Barre de pontage tri 4 appareils 60A	AF200033799	
10	Borne de raccordement 25 mm ²	AF200033798	
11	Contacteur triphasé 25A 230V	AF270010100	x
12	Adjonction inverseur électrique	AF270012000	
13	Socle relai 4RT	AF200033711	
14	Relai 4RT 10A 230V	AF200033586	x
15	Temporisation fond armoire Multigamme	AF200033674	x
16	Télerupteur 230V bipolaire inverseur	AF200033440	x
17	Transformateur mono 200 VA400/230V	AF270010501	x
18	Borne 6 mm ² vert jaune	AF200030274	
19	Borne sans vis 3 x 2,5mm ²	AF200033794	
20	Cloison de borne terminale	AF200033795	
21	Peigne liaison 2,5 mm ² 10 pôles	AF200033796	
22	Serre Câble 95 mm ²	AF200033049	
23	Fusible 10 x 38 1A gi	AF200033203	x
24	Fusible 10 x 38 2A am	AF200033722	x
25	Fusible 10 x 38 8A am	AF200030523	x
26	Fusible 10 x 38 16A gi	AF200033146	x

8.24. ELECTRIC M1E 208/230V ELECTRICAL CABINET BACK PARTS LIST

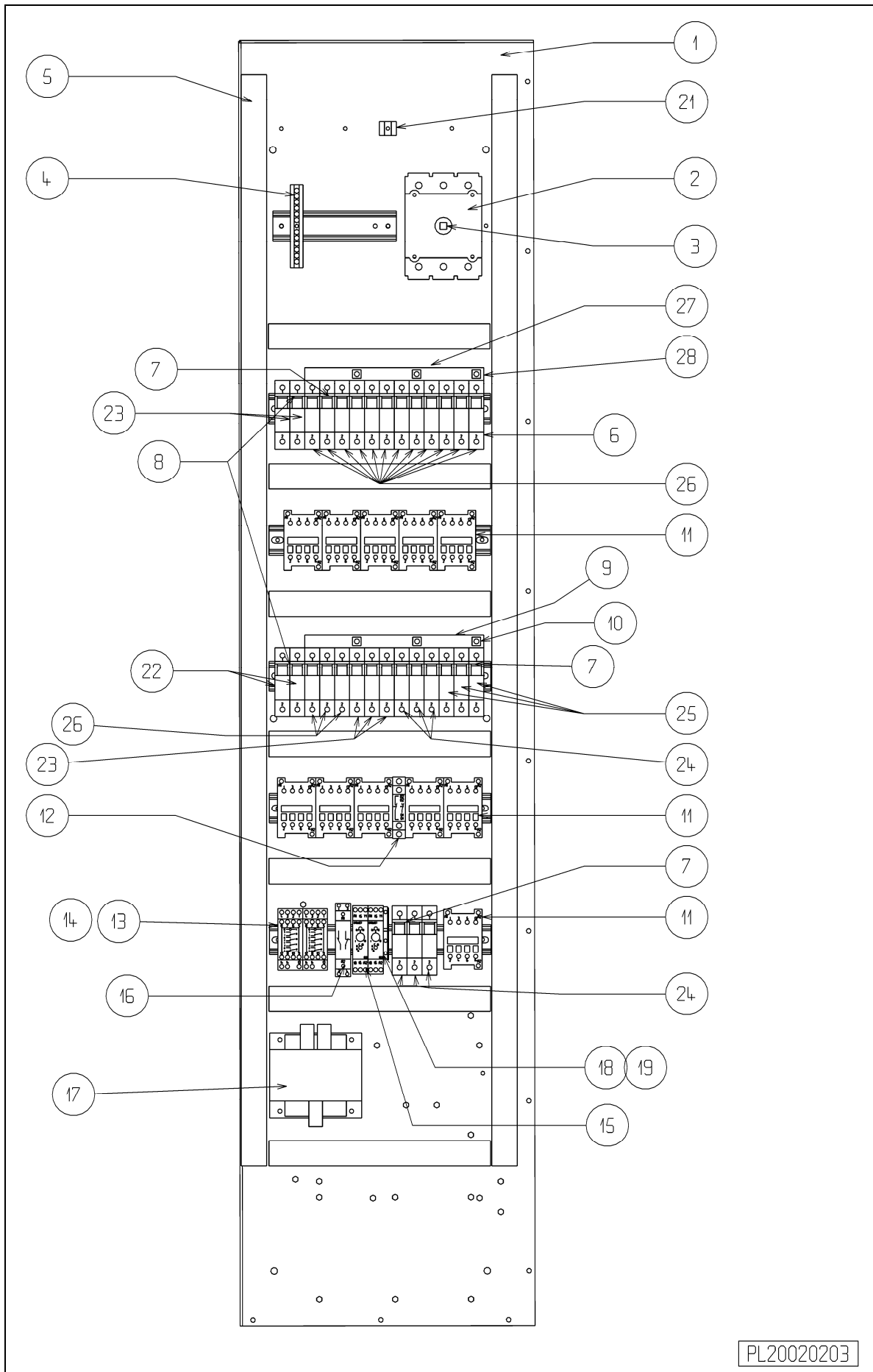

Electric M1 208/230V electrical cabinet back parts list

Rep.	Désignation	208/230V	S.A.V.
1	Fond coffret	AF220005492	
2	Inter sectionneur tri 125A	AF200033741	
3	Rallonge d'axe	AF200033576	
4	Bornier vert 12 plots	AF200033797	
5	Goulotte de câblage	AF200033005	
6	Porte fusible 10,3 x 38	AF200033502	
7	Kit d'association 3 pôles	AF200033218	
8	Kit d'association 2 pôles	AF200033215	
9	Barre de pontage tri 4 appareils 60A	AF200033799	
10	Borne de raccordement 25 mm ²	AF200033798	
11	Contacteur triphasé 25A 230V	AF270010100	x
12	Adjonction inverseur électrique	AF270012000	
13	Socle relai 4RT	AF200033711	
14	Relai 4RT 10A 230V	AF200033586	x
15	Temporisation fond armoire Multigamme	AF200033674	x
16	Télérupteur 230V bipolaire inverseur	AF200033440	x
17	Transformateur mono 200 VA400/230V	AF270010501	x
18	Borne sans vis 3 x 2,5mm ²	AF200033794	
19	Cloison de borne terminale	AF200033795	
20	Peigne liaison 2,5 mm ² 10 pôles	AF200033796	
21	Serre Câble 95 mm ²	AF200033049	
22	Fusible 10 x 38 1A gi	AF200033203	x
23	Fusible 10 x 38 2A am	AF200033722	x
24	Fusible 10 x 38 4A am	AF200033144	x
25	Fusible 10 x 38 8A am	AF200030523	x
26	Fusible 10 x 38 25A gi	AF200033147	x
27	Barre de pontage tri 20 appareils 96A	AF200033809	
28	Borne de raccordement 50 mm ²	AF200033806	

8.25. ELECTRIC M2E 380/415V ELECTRICAL CABINET BACK PARTS LIST

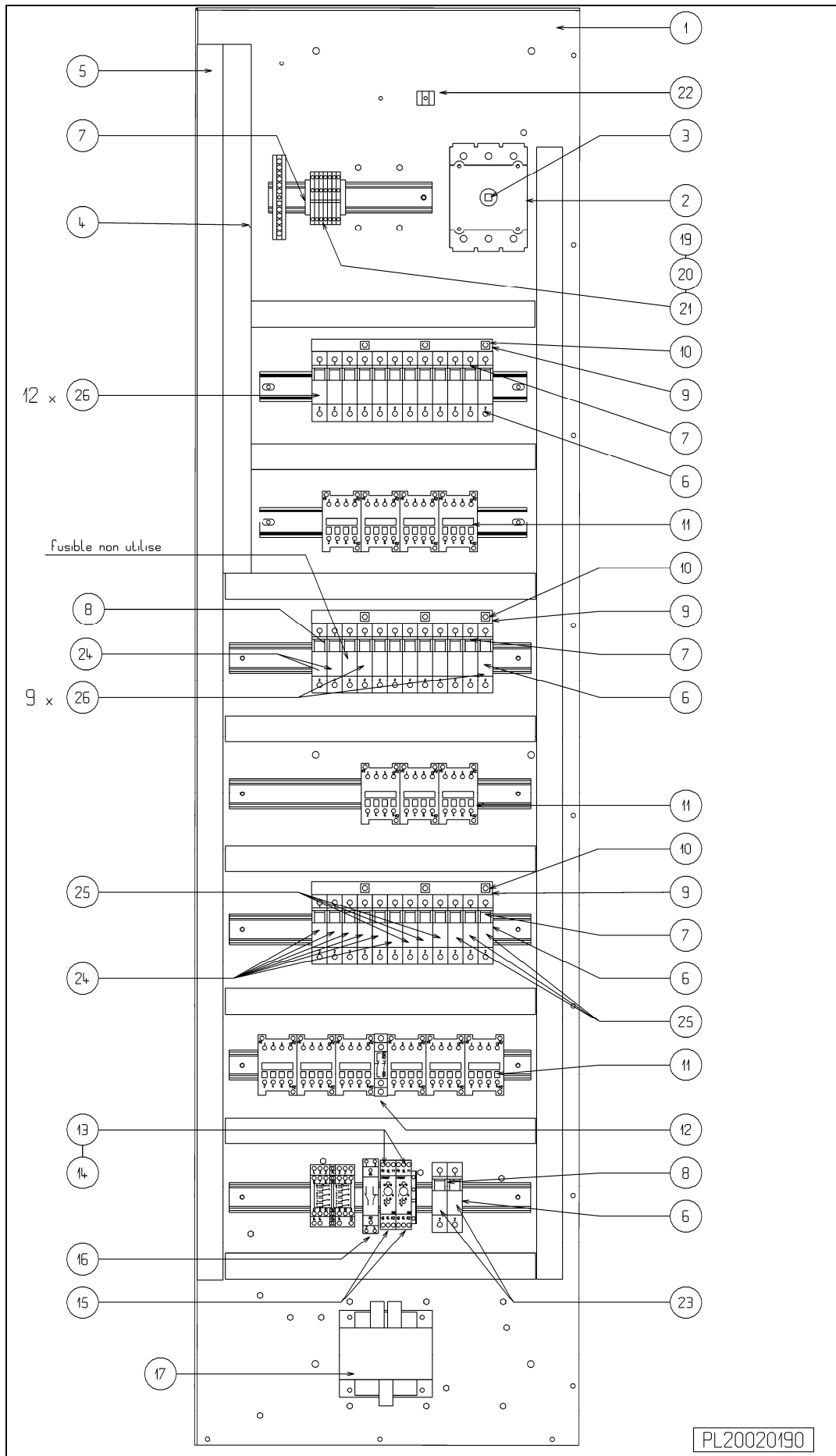

Electric M2 380/415V electrical cabinet back parts list

Rep.	Désignation	380/415V	S.A.V.
1	Fond coffret	AF220005492	
2	Inter sectionneur tri 125A	AF200033741	
3	Rallonge d'axe	AF200033576	
4	Bornier vert 12 plots	AF200033797	
5	Goulotte de cablage	AF200033005	
6	Porte fusible 10,3 x 38	AF200033502	
7	Kit d'association 3 pôles	AF200033218	
8	Kit d'association 2 pôles	AF200033215	
9	Barre de pontage tri 4 appareils 60A	AF200033799	
10	Borne de raccordement 25 mm ²	AF200033798	
11	Contacteur triphasé 25A 230V	AF270010100	x
12	Adjonction inverseur électrique	AF270012000	
13	Socle relai 4RT	AF200033711	
14	Relai 4RT 10A 230V	AF200033586	x
15	Temporisation fond armoire multigamme	AF200033674	x
16	Télérupteur 230V bipolaire inverseur	AF200033440	x
17	Transformateur mono 200VA 400/230V	AF270010501	x
18	Borne 6 mm ² vert jaune	AF200030274	
19	Borne sans vis 3 x 2,5 mm ²	AF200033794	
20	Cloison de borne terminale	AF200033795	
21	Peigne liaison 2,5 mm ² 10 pôles	AF200033796	
22	Serre Câble 95 mm ²	AF200033049	
23	Fusible 10 x 38 1A gi	AF200033203	x
24	Fusible 10 x 38 2A am	AF200033722	x
25	Fusible 10 x 38 8A am	AF200030523	x
26	Fusible 10 x 38 16A gi	AF200033146	x
27	Barette de pontage tri 20 appareils 96A	AF200033801	

8.26. ELECTRIC M2E 208/230V ELECTRICAL CABINET BACK PARTS LIST

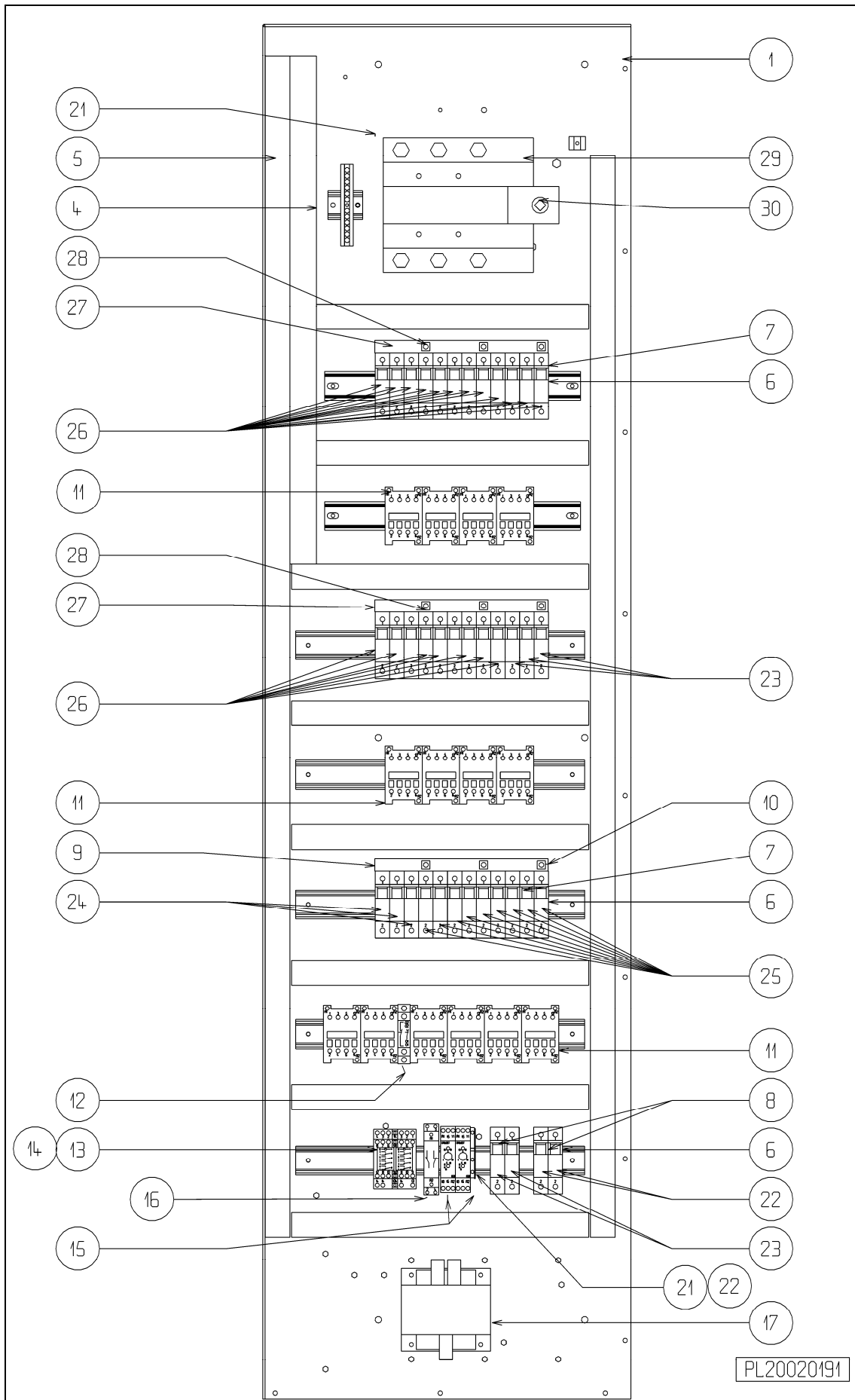

Electric M2 208/230V electrical cabinet back parts list

Rep.	Désignation	208/230V	S.A.V.
1	Fond coffret	AF220005492	
2	Inter sectionneur tri 125A	AF200033741	
3	Rallonge d'axe	AF200033576	
4	Bornier vert 12 plots	AF200033797	
5	Goulotte de cablage	AF200033005	
6	Porte fusible 10,3 x 38	AF200033502	
7	Kit d'association 3 pôles	AF200033218	
8	Kit d'association 2 pôles	AF200033215	
9	Barre de pontage tri 4 appareils 60A	AF200033799	
10	Borne de raccordement 25 mm ²	AF200033798	
11	Contacteur triphasé 25A 230V	AF270010100	x
12	Adjonction inverseur électrique	AF270012000	
13	Socle relai 4RT	AF200033711	
14	Relai 4RT 10A 230V	AF200033586	x
15	Temporisation fond armoire multigamme	AF200033674	x
16	Télerupteur 230V bipolaire inverseur	AF200033440	x
17	Transformateur mono 200VA 400/230V	AF270010501	x
18	Borne 6 mm ² vert jaune	AF200033794	
19	Borne sans vis 3 x 2,5 mm ²	AF200033795	
20	Cloison de borne terminale	AF200033795	
21	Peigne liaison 2,5 mm ² 10 pôles	AF200033796	
22	Serre Câble 95 mm ²	AF200033049	
23	Fusible 10 x 38 1A gi	AF200033203	x
24	Fusible 10 x 38 2A am	AF200033722	x
25	Fusible 10 x 38 4A am	AF200033144	x
26	Fusible 10 x 38 8A am	AF200030523	x
27	Fusible 10 x 38 25A gi	AF200033147	x
28	Barette de pontage tri 20 appareils 96A	AF200033801	
29	Borne de raccordement 50 mm ²	AF200033806	
30	Inter sectionneur tri 250A	AF200033807	
31	Commande extérieure frontale 250A	AF200033808	

8.27. ELECTRIC M1 ELECTRICAL CABINET PARTS LIST

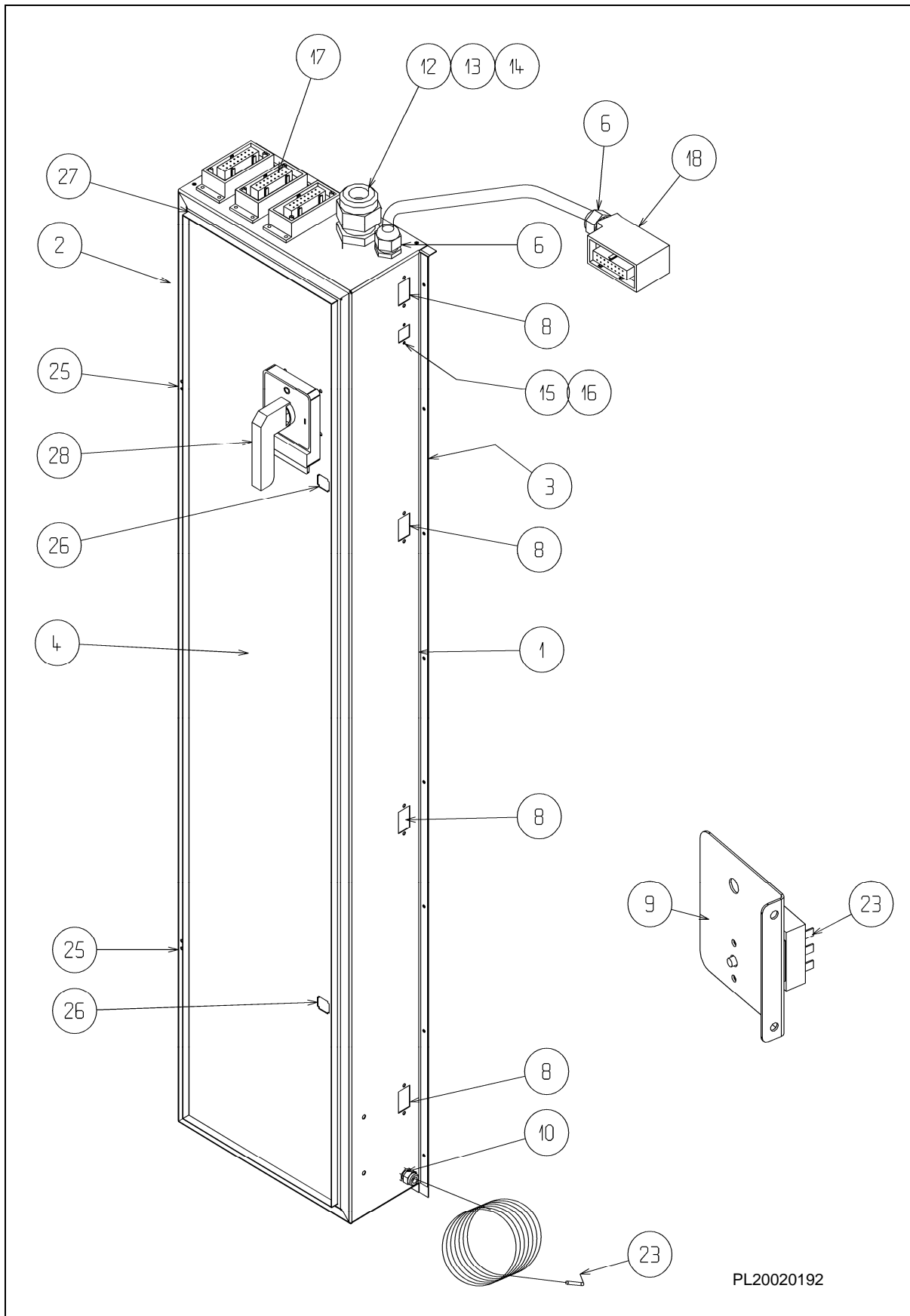

Electric M1 electrical cabinet parts list

Rep.	Désignation	M1	S.A.V.
1	Côté droit coffret	AF220005491	
2	Côté gauche coffret	AF220005490	
3	Fond monté	AF220005741	
4	Porte coffret	AF220005493	
5	Bouche trou connecteur		
6	Presse étoupe 21 plastique	AF200033058	
	Contre écrou 21 plastique	AF200033059	
8	Connecteurs moteurs cablés 380V	AF220005709	
	Connecteurs moteurs cablés 230V	AF220005770	
9	Support thermostat	AF220005595	
10	Presse étoupe 9 plastique	AF200033776	
	Contre écrou 9 plastique	AF200033777	
11	Presse étoupe 36 plastique	AF200033087	
12	Contre écrou 36 plastique	AF200033094	
13	Presse étoupe 29 plastique	AF200033088	
14	Réducteur presse étoupe 36-21	AF200030193	
15	Embase 3-4 pôles + terre 10A	AF200033781	
16	Insert femelle 4 pôles + terre	AF200033784	
17	Connecteur cablé 1mm ² 16 plots	AF220005710	
18	Connecteur 16 plots coffret plafond	AF220005714	
23	Thermostat de sécurité 340°C	AF200033362	x
25	Charnière de porte	AF220005262	
26	1/4 de tour serrure	AF220005265	
27	Joint de porte	AF220005290	
28	Poignée intersectionneur 380V	AF200033578	
	Poignée intersectionneur 230V	AF200033578	

8.28. M2 ELECTRICAL CABINET PARTS LIST

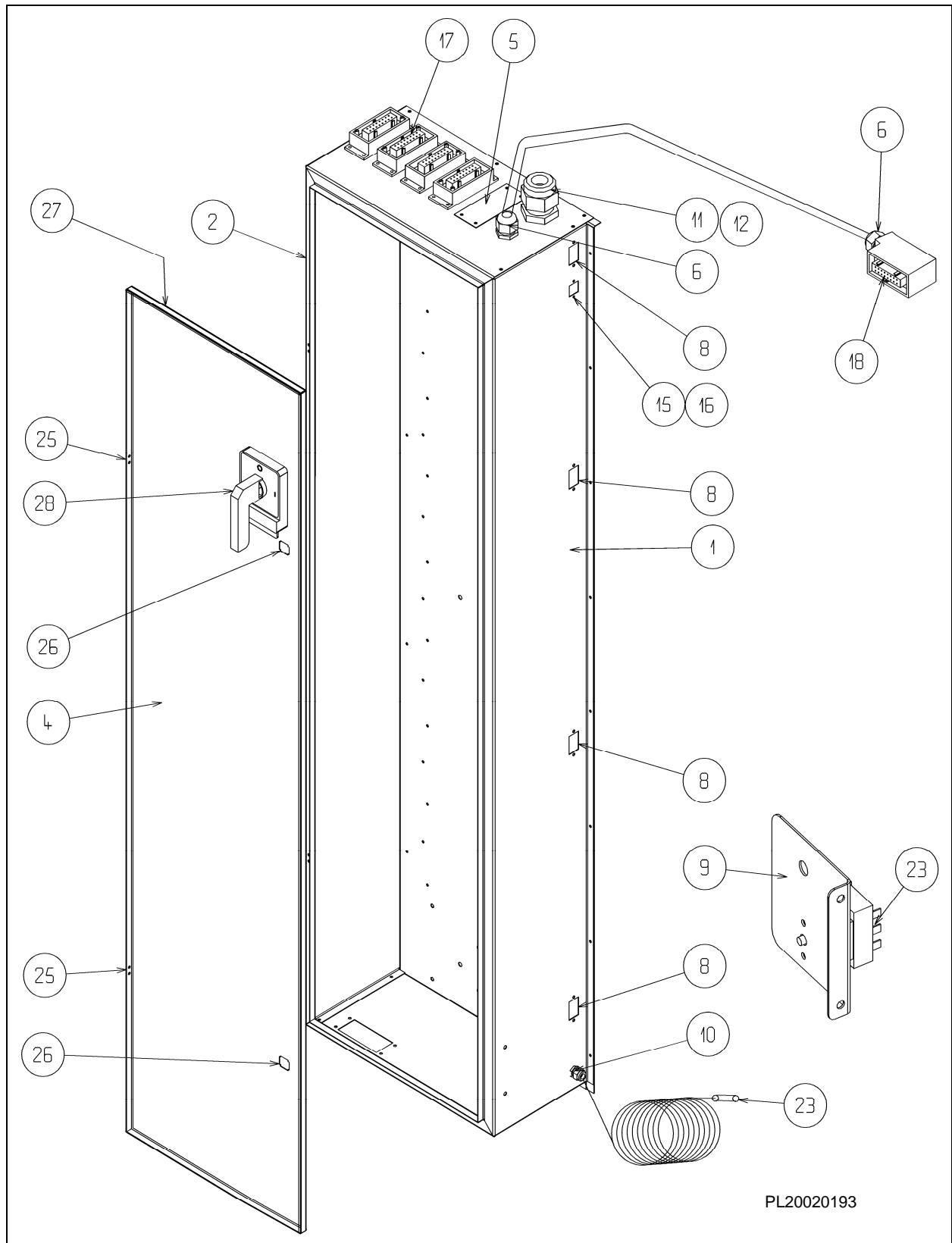

M2 electrical cabinet parts list

Rep.	Désignation	M2	S.A.V.
1	Côté droit coffret	AF220005597	
2	Côté gauche coffret	AF220005599	
3	Fond monté	AF220005742	
4	Porte coffret	AF220005596	
5	Bouche trou connecteur	AF220005598	
6	Presse étoupe 21 plastique	AF200033058	
	Contre écrou 21 plastique	AF200033059	
8	Connecteurs moteurs cablés 380V	AF220005709	
	Connecteurs moteurs cablés 230V	AF220005770	
9	Support thermostat	AF220005595	
10	Presse étoupe 9 plastique	AF200033776	
	Contre écrou 9 plastique	AF200033777	
11	Presse étoupe 36 plastique	AF200033087	
12	Contre écrou 36 plastique	AF200033094	
13	Presse étoupe 29 plastique		
14	Réducteur presse étoupe 36-21		
15	Embase 3-4 pôles + terre 10A	AF200033781	
16	Insert femelle 4 pôles + terre	AF200033784	
17	Connecteur cablé 1mm ² 16 plots	AF220005710	
18	Connecteur 16 plots coffret plafond	AF220005714	
23	Thermostat de sécurité 340°C	AF200033362	x
25	Charnière de porte	AF220005262	
26	1/4 de tour serrure	AF220005265	
27	Joint de porte	AF220005290	
28	Poignée intersectionneur 380V	AF200033578	
	Poignée intersectionneur 230V	AF200033808	

9. EXPLODED VIEWS FOR ASSEMBLY

9.1. ELECTRIC OVEN

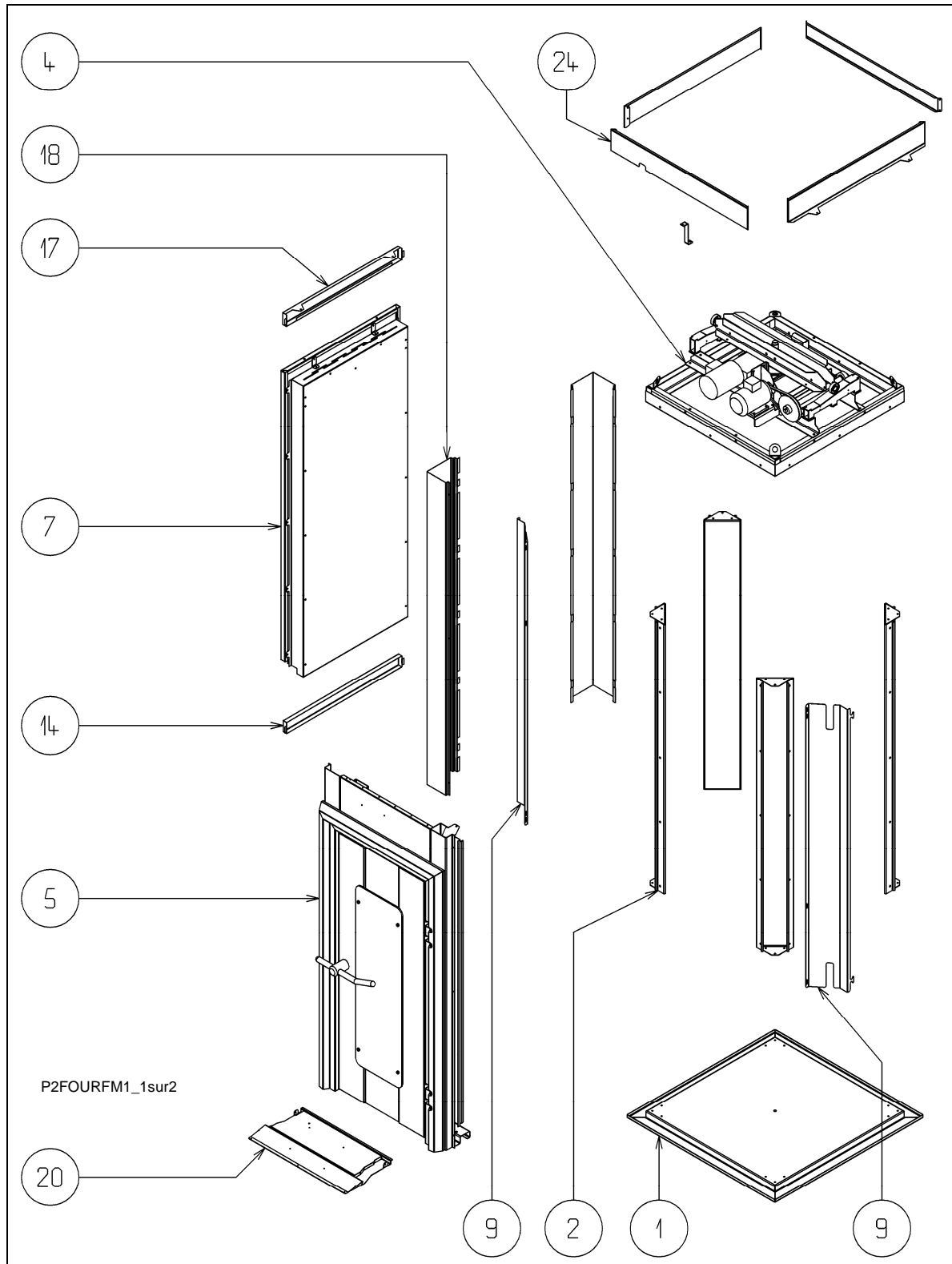

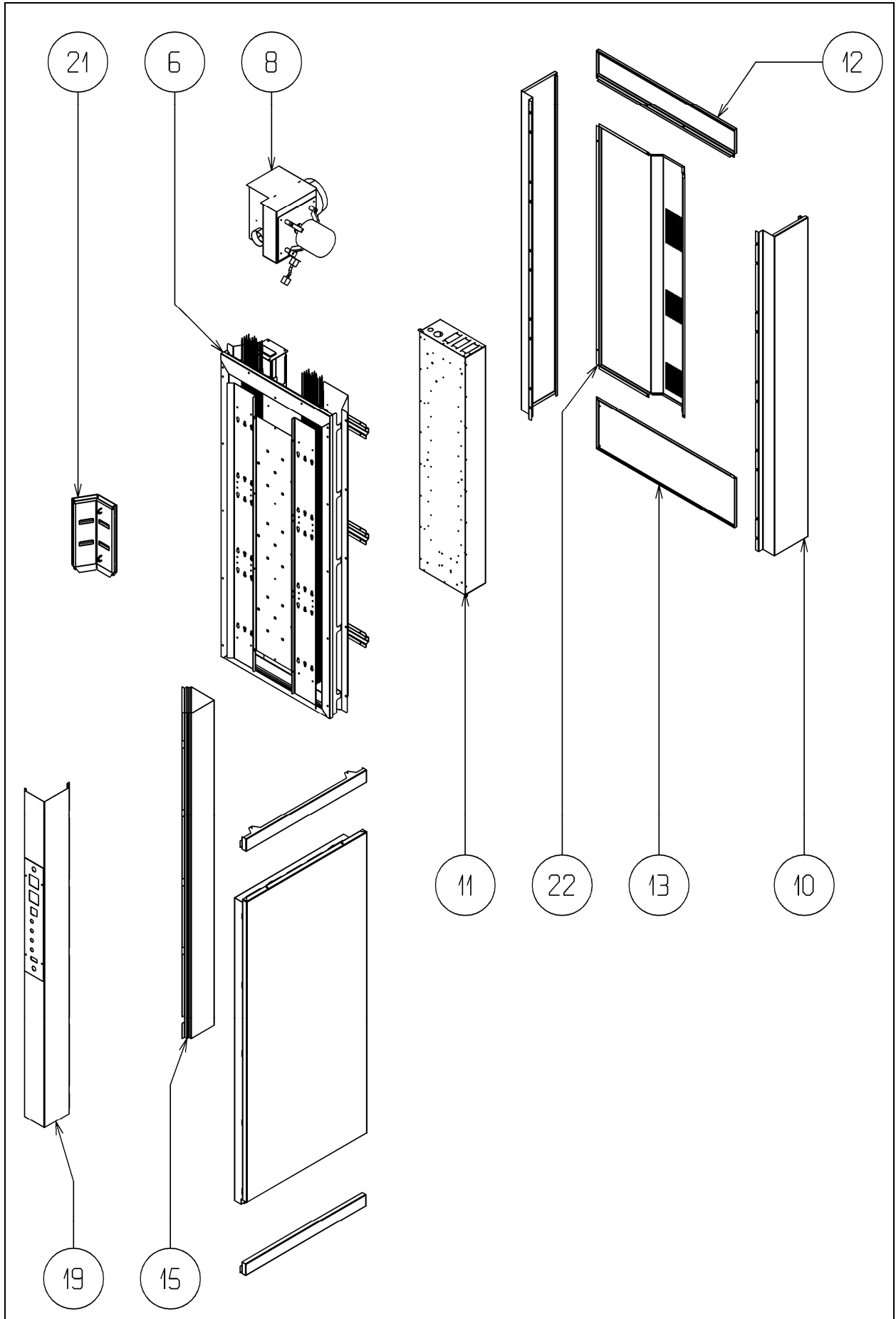

ELECTRIC OVEN

Rep.	Désignation		M1	M2	
1	Plancher		AF220005151	AF220005051	
2	Pilier		AF220005176	AF220005054	
4	Plafond	Porte droite	400V	AF220005611	AF220005612
			208/230V	AF220006590	AF220006591
		Porte gauche	400V	AF220014591	AF220014593
			208/230V	AF220014590	AF220014592
5	Bloc porte	droit	AF220005600	AF220005601	
		gauche	AF220014520	AF220014540	
6	Bloc chauffe	50Hz	AF220005607	AF220005608	
		60Hz	AF220006650	AF220006651	
7	Panneau		AF220005192	AF220005135	
8	Extracteur		AF220005604	AF220005605 →10/00 →11/00: AF220006670	
9	Tôle calorifuge avant		AF220005439	AF220005446	
10	Jaquette latérale		AF220005687	AF220005688	
11	Coffret électrique	400 V	AF220005731	AF220005733	
		208/230V	AF220005732	AF220005734	
12	Traverse arrière haute		AF220005690	AF220005691	
13	Traverse arrière basse		AF220005692	AF220005693	
14	Plinthe		AF220005183	AF220005120	
15	Angle arrière		AF220005199	AF220005121	
17	Bandeau		AF220005184	AF220005122	
18	Angle avant		AF220005148	AF220005124	
19	Angle avant droit câblé	50 Hz	AF220005715	AF220005726	
		60 Hz	AF220005782	AF220005783	
	Angle avant gauche câblé	50 Hz	AF220005737	AF220005738	
		60 Hz	AF220005785	AF220005786	
20	Pan incliné	Porte droite	AF220005626	AF220005627	
		Porte gauche	AF220014500	AF220014506	
21	Boîte à buée		AF220005668	AF220005670	
22	Jaquette arrière		AF220005699	AF220005128	
24	Ceinture supérieure				
	COMPRENANT				
	Ceinture avant	Porte droite	AF220005655	AF220005658	
		Porte gauche	AF220014580	AF220014581	
	Ceinture latérale		AF220005656	AF220005659	
	Ceinture arrière		AF220005657	AF220005660	
	Support		AF220005664	AF220005664	

9.2. OIL/GAS OVEN REAR

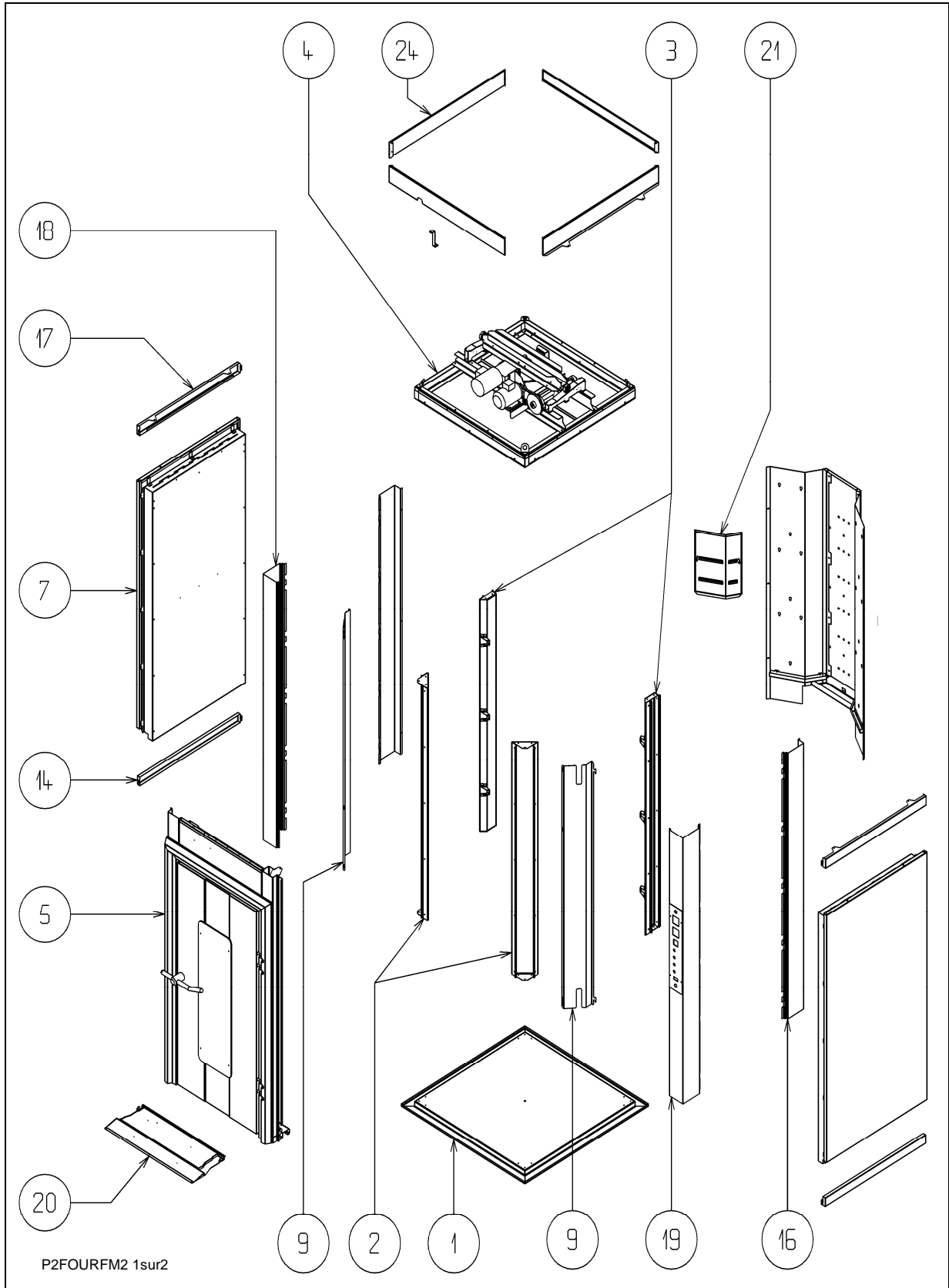

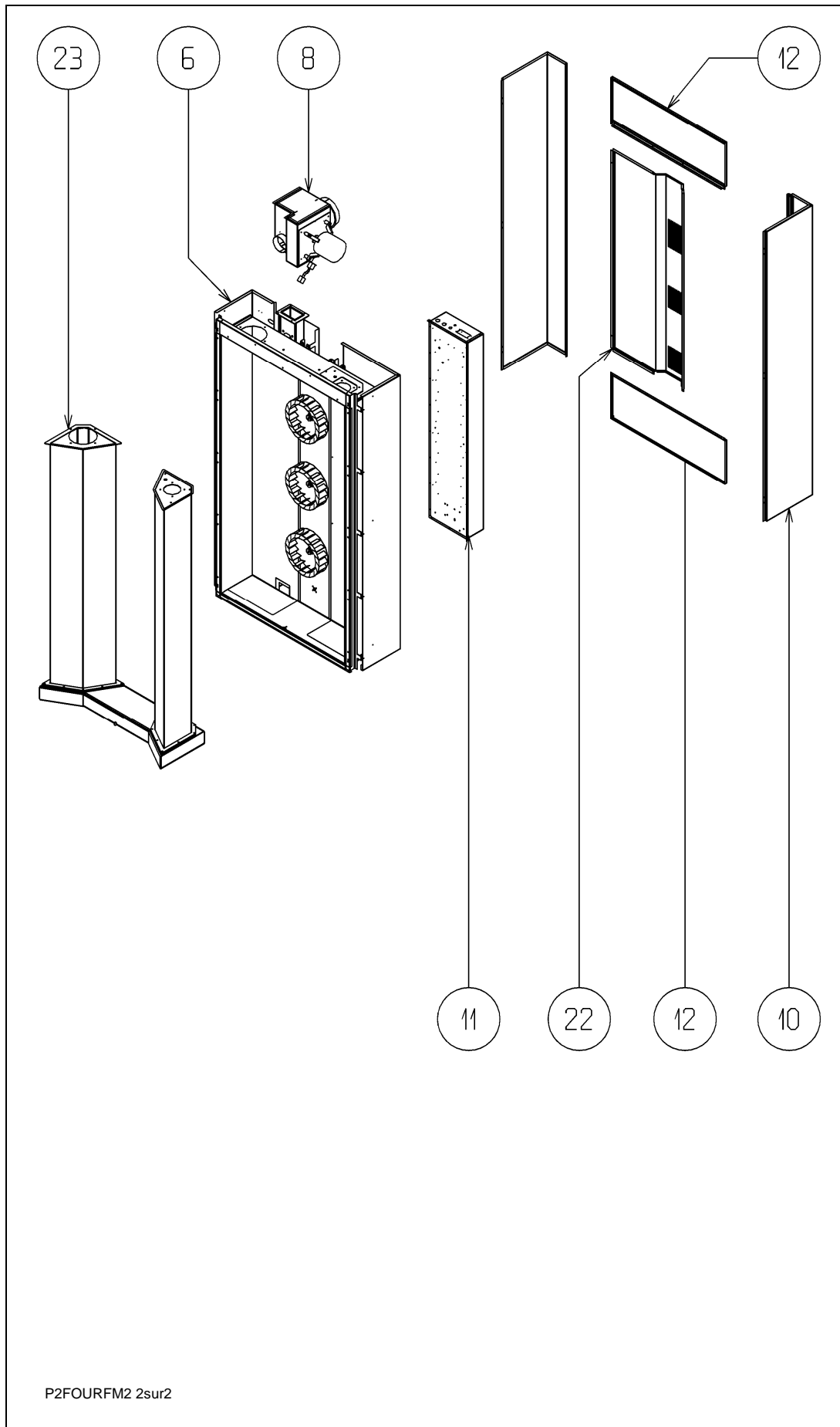

OIL/GAS OVEN REAR

Rep.	Désignation		M1	M2	
1	Plancher		AF220005151	AF220005051	
2	Pilier standard		AF220005176	AF220005054	
3	Pilier Mazout/Gaz		AF220005470	AF220005471	
4	Plafond	Porte droite	400V	AF220005611	AF220005612
			208/230V	AF220006590	AF220006591
		Porte gauche	400V	AF220014591	AF220014593
			208/230V	AF220014590	AF220014592
5	Bloc porte	Droit	AF220005600	AF220005601	
		Gauche	AF220014520	AF220014540	
6	Bloc chauffe	50Hz	AF220005615	AF220005616	
		60Hz	AF220006655	AF220006656	
7	Panneau		AF220005192	AF220005135	
8	Extracteur		AF220005604	AF220005605 →10/00	
				→11/00 AF220006670	
9	Tôle calorifuge avant		AF220005439	AF220005446	
10	Jaquette latérale bloc chauffe		AF220005694	AF220005695	
11	Coffret électrique	400V	AF220005729	AF220005729	
		208/230V	AF220005730	AF220005730	
12	Traverse arrière bloc chauffe		AF220005697	AF220005698	
14	Plinthe		AF220005183	AF220005120	
16	Angle arrière Mazout/Gaz		AF220005570	AF220005585	
17	Bandeau		AF220005184	AF220005122	
18	Angle avant		AF220005148	AF220005124	
19	Angle avant droit câblé	50 Hz	AF220005715	AF220005726	
		60 Hz	AF220005782	AF220005783	
	Angle avant gauche câblé	50 Hz	AF220005737	AF220005738	
		60 Hz	AF220005785	AF220005786	
20	Pan incliné	Porte droite	AF220005626	AF220005627	
		Porte gauche	AF220014500	AF220014506	
21	Boîte à buée		AF220005669	GA AF220005671	
				DR AF220005672	
22	Jaquette arrière bloc chauffe		AF220005699	AF220005699	
23	Echangeur		AF220005619	AF220005620	
24	Ceinture supérieure				
	COMPRENANT				
	Ceinture avant	Porte droite	AF220005655	AF220005658	
		Porte gauche	AF220014580	AF220014581	
	Ceinture latérale		AF220005656	AF220005659	
	Ceinture arrière		AF220005657	AF220005660	
	Support		AF220005664	AF220005664	

9.3. OIL/GAS OVEN SIDE

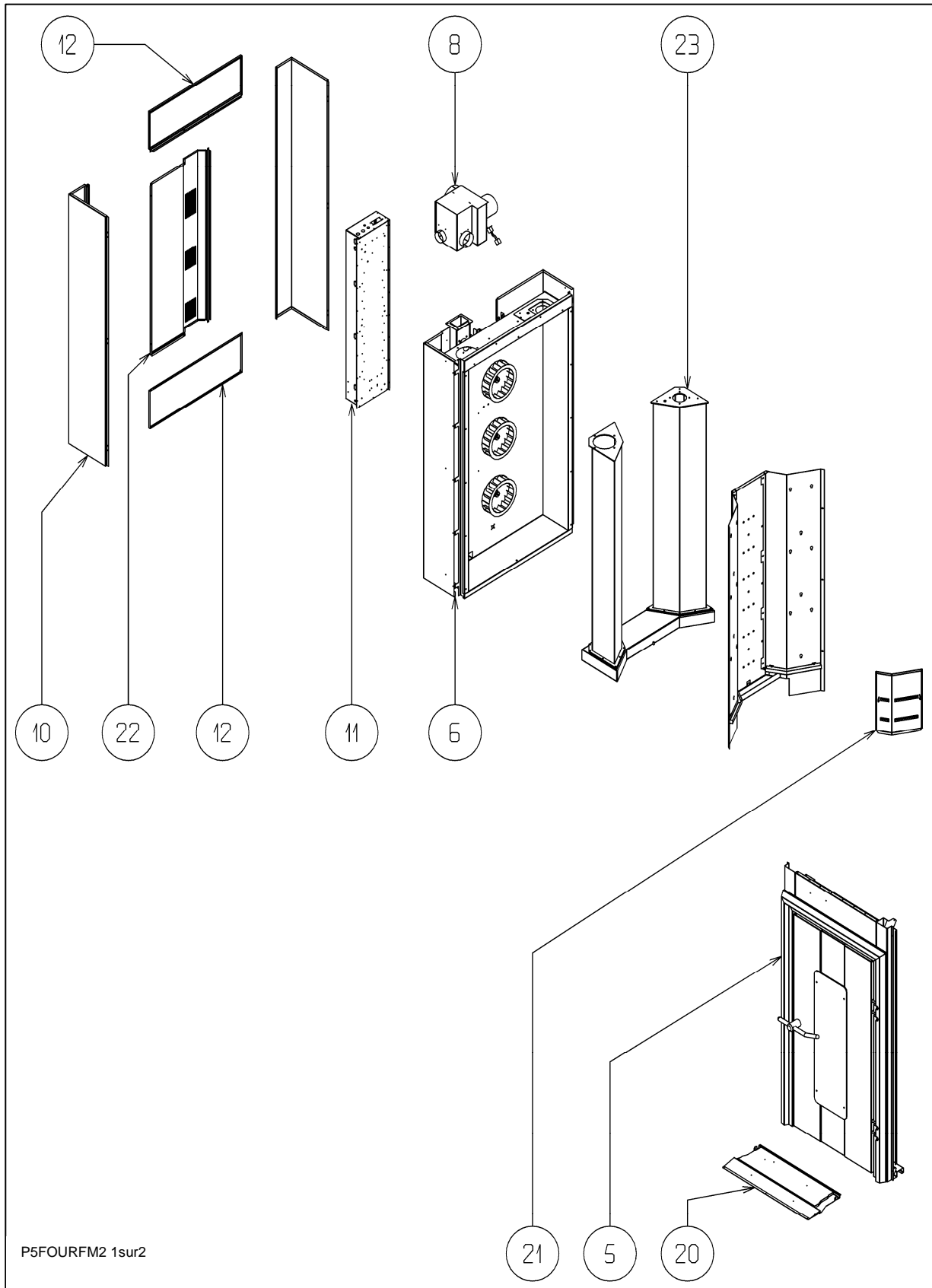

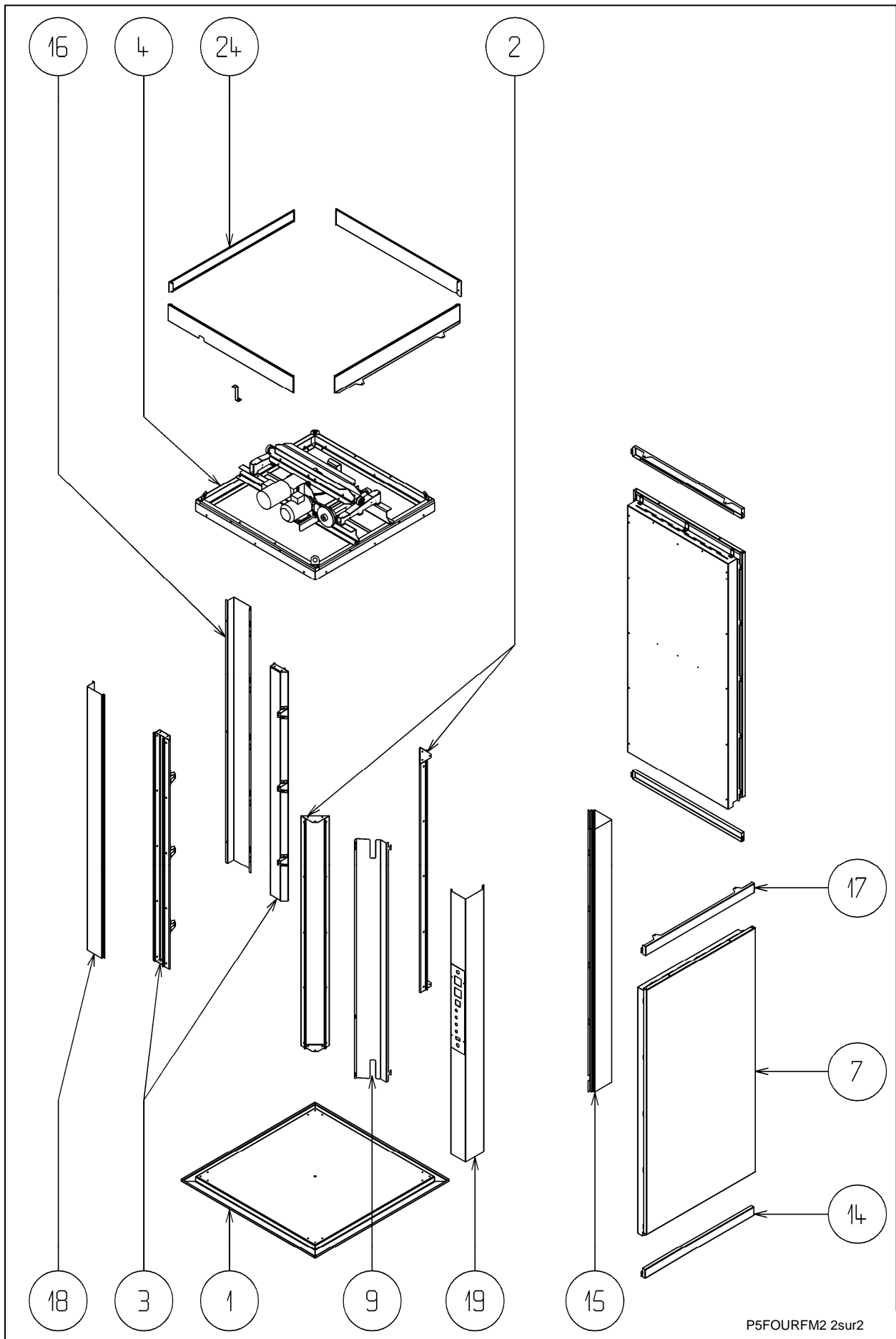

P5FOURFM2 2sur2

OIL/GAS OVEN SIDE

Rep.	Désignation		M1	M2	
1	Plancher		AF220005151	AF220005051	
2	Pilier standard		AF220005176	AF220005054	
3	Pilier Mazout/Gaz		AF220005470	AF220005471	
4	Plafond	Porte droite	400V	AF220005611	AF220005612
			208/230V	AF220006590	AF220006591
		Porte gauche	400V	AF220014591	AF220014593
			208/230V	AF220014590	AF220014592
5	Bloc porte	droit	AF220005600	AF220005601	
		gauche	AF220014520	AF220014540	
6	Bloc chauffe	50Hz	AF220005615	AF220005616	
		60Hz	AF220006655	AF220006656	
7	Panneau		AF220005192	AF220005135	
8	Extracteur		AF220005604	AF220005605 →10/00	
				→11/00: AF220006670	
9	Tôle calorifuge avant		AF220005439	AF220005446	
10	Jaquette latérale bloc chauffe		AF220005694	AF220005695	
11	Coffret électrique	400V	AF220005729	AF220005729	
		208/230V	AF220005730	AF220005730	
12	Traverse arrière bloc chauffe		AF220005697	AF220005698	
14	Plinthe		AF220005183	AF220005120	
15	Angle arrière		AF220005199	AF220005121	
16	Angle arrière Mazout/Gaz		AF220005570	AF220005585	
17	Bandeau		AF220005184	AF220005122	
18	a) Angle avant Mazout/Gaz		AF220005587	AF220005572	
	b) Angle avant GAU câblé	50 Hz	AF220005737	AF220005738	
		60 Hz	AF220005785	AF220005786	
19	a) Angle avant DROIT câblé	50 Hz	AF220005715	AF220005726	
		60 HZ	AF220005782	AF220005783	
	b) Angle avant Mazout/Gaz		AF220005587	AF220005572	
20	Pan incliné	Porte droite	AF220005626	AF220005627	
		Porte gauche	AF220014500	AF220014506	
21	Boîte à buée		AF220005669	GA AF220005671	
				DR AF220005672	
22	Jaquette arrière bloc chauffe		AF220005699	AF220005699	
23	Echangeur		AF220005619	AF220005620	
24	Ceinture supérieure				
	COMPRENANT				
	Ceinture avant	Porte droite	AF220005655	AF220005658	
		Porte gauche	AF220014580	AF220014581	
	Ceinture latérale		AF220005656	AF220005659	
	Ceinture arrière		AF220005657	AF220005660	
	Support		AF220005664	AF220005664	

- a) Heating unit on the left
b) Heating unit on the right

9.4. ELECTRIC HEATING UNIT

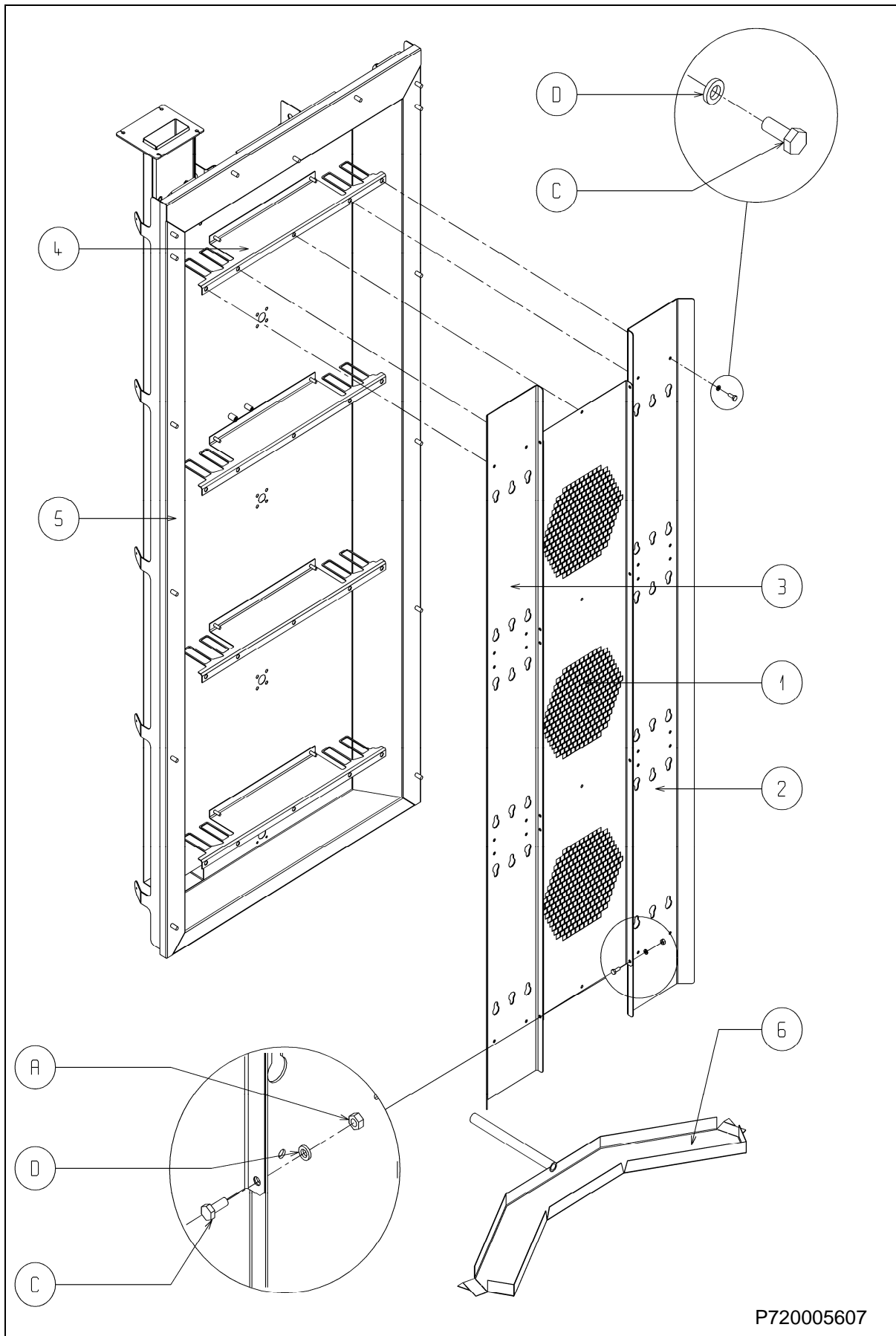

P720005607

9.5. OIL/GAS HEATING UNIT

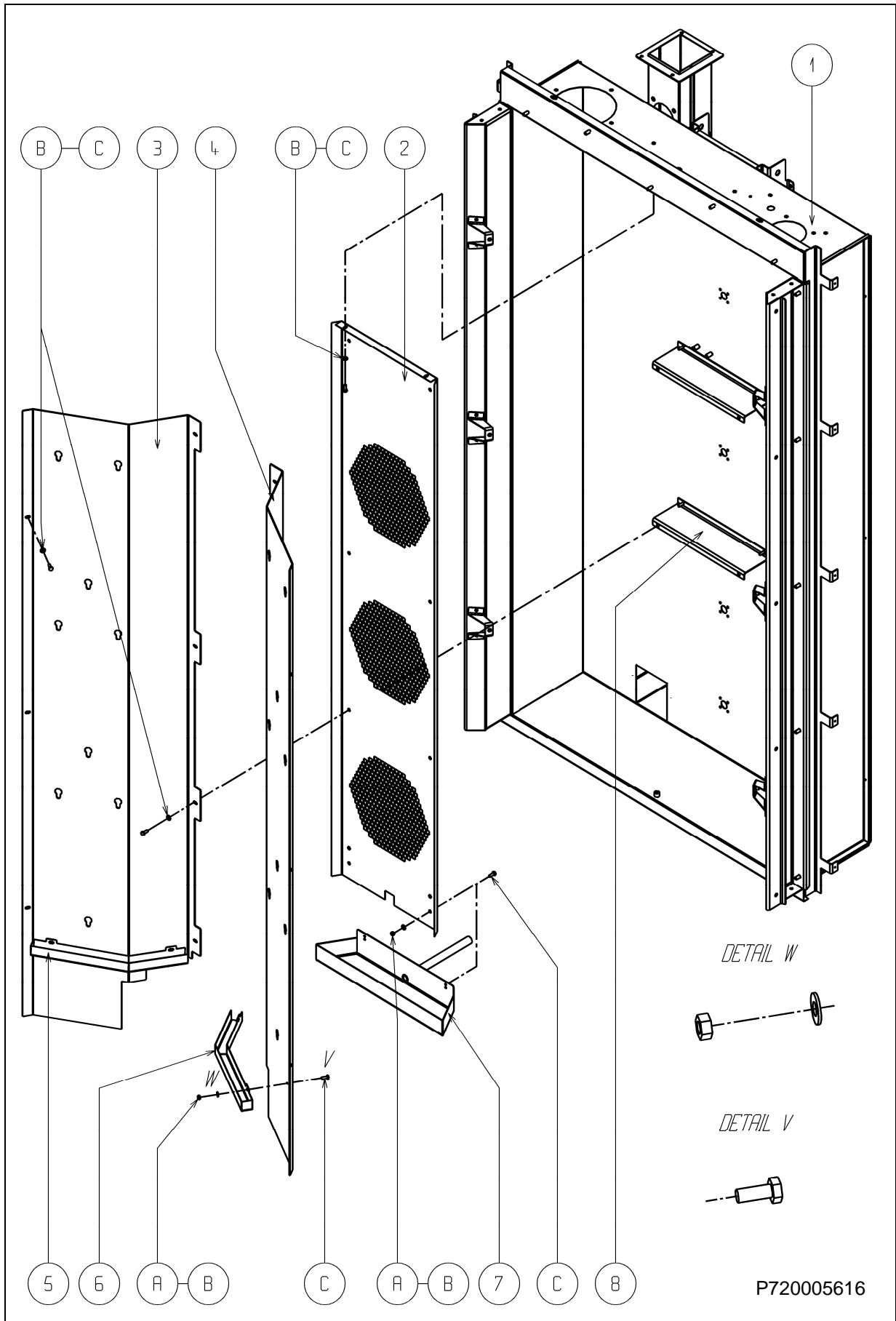

9.6. HEAT EXCHANGER

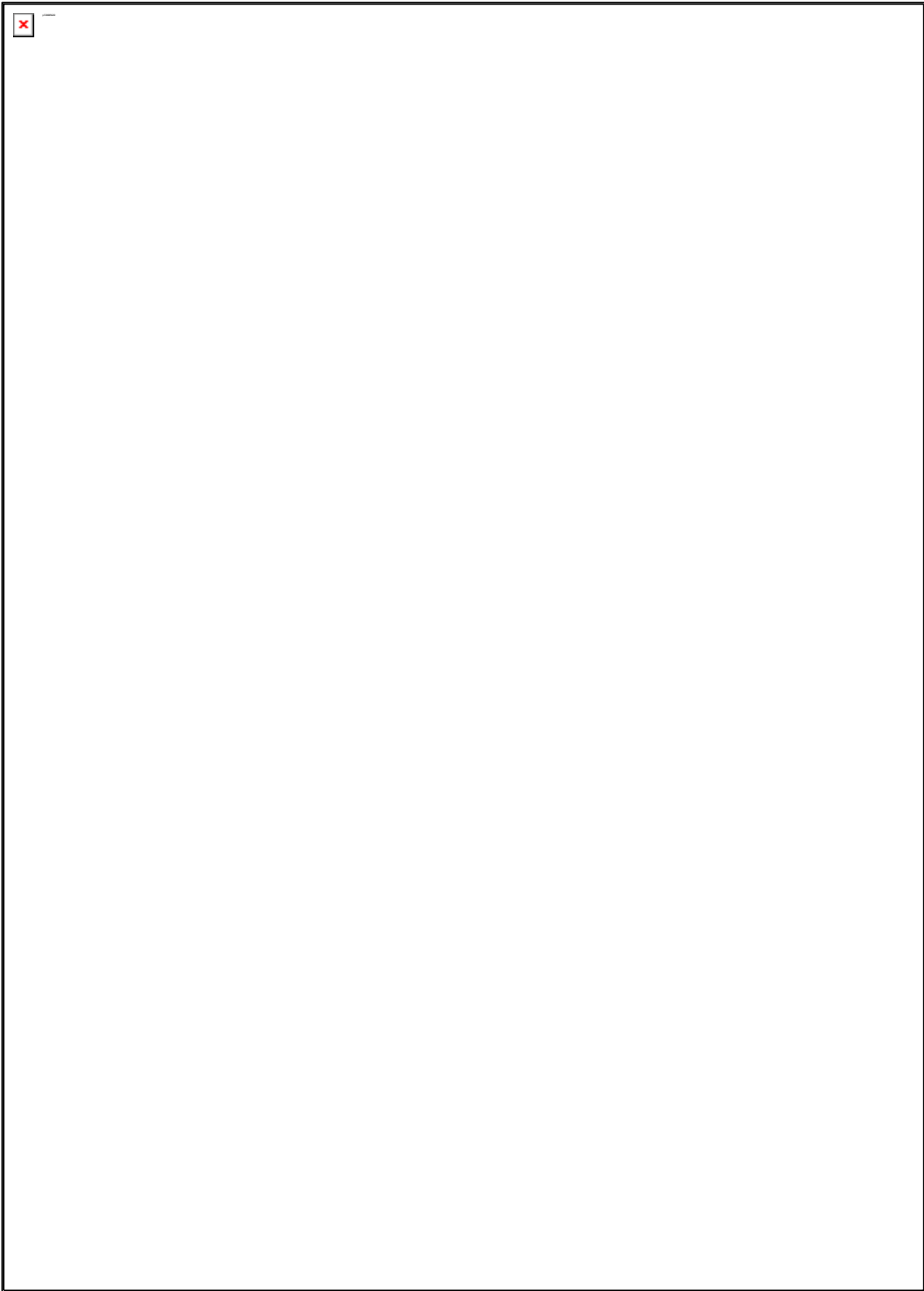

9.7. SQUIRREL CAGE

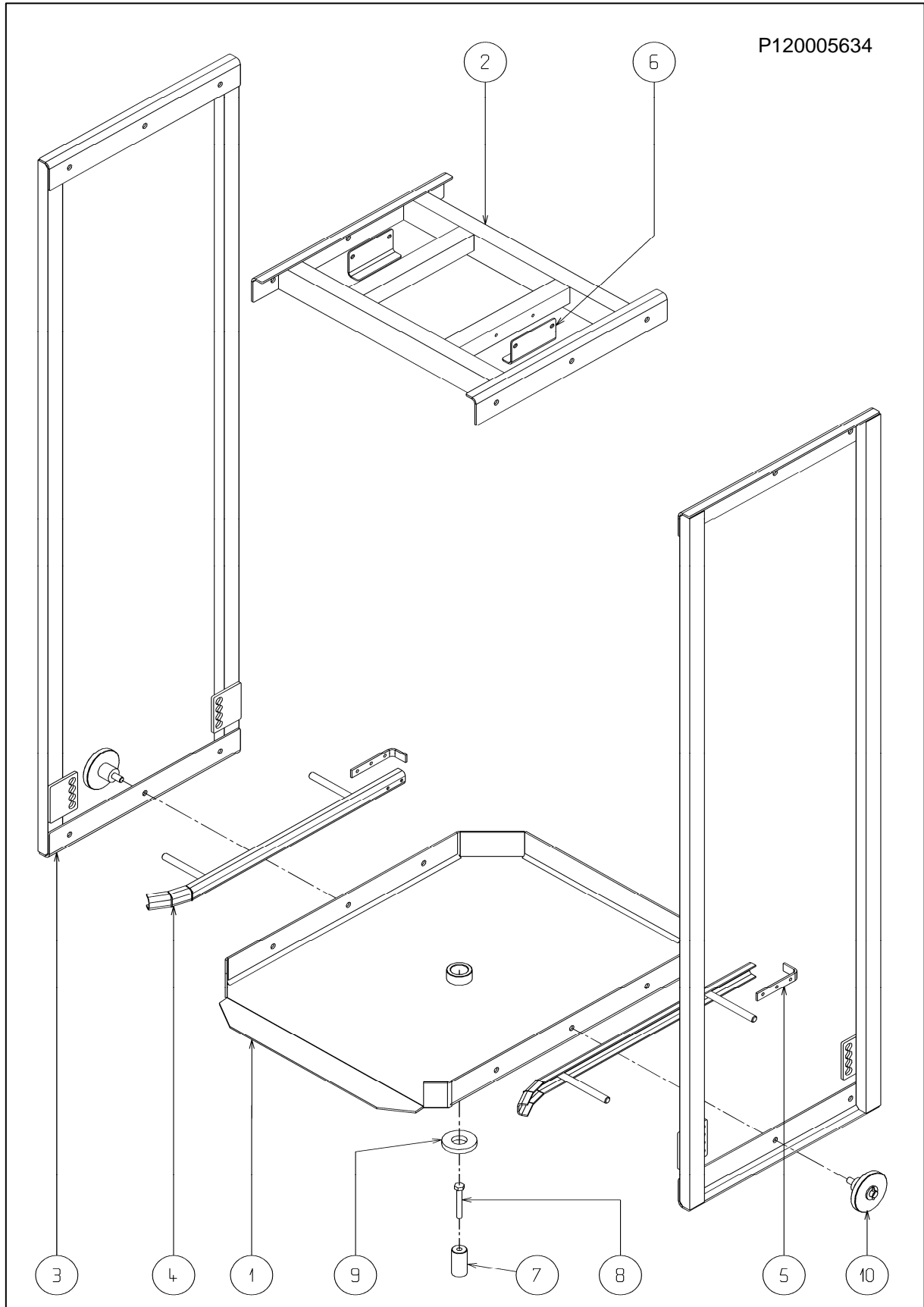

9.8. OIL/GAS M1-M2 STEAM GENERATOR

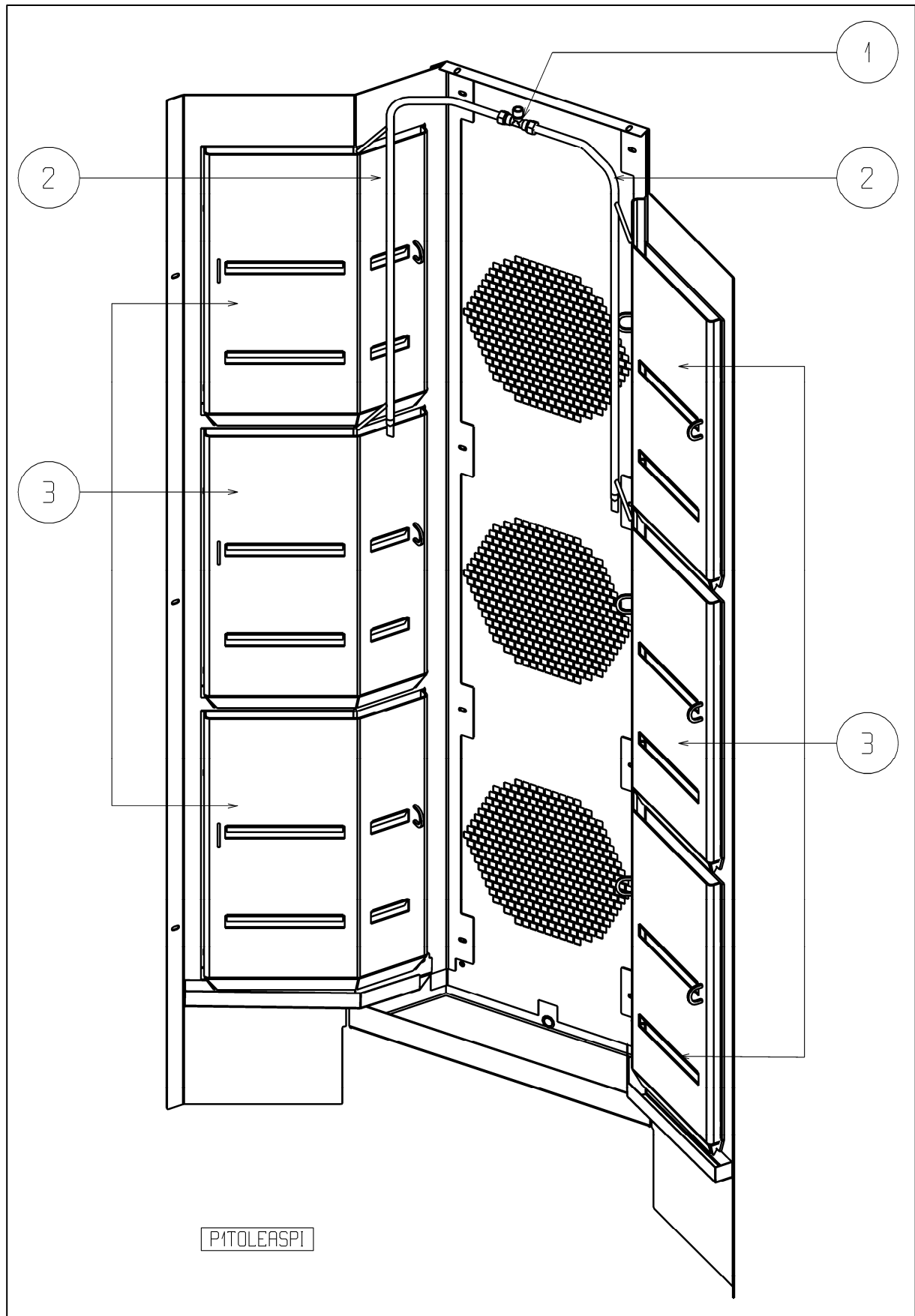

9.9. ELECTRIC M1-M2 STEAM GENERATOR

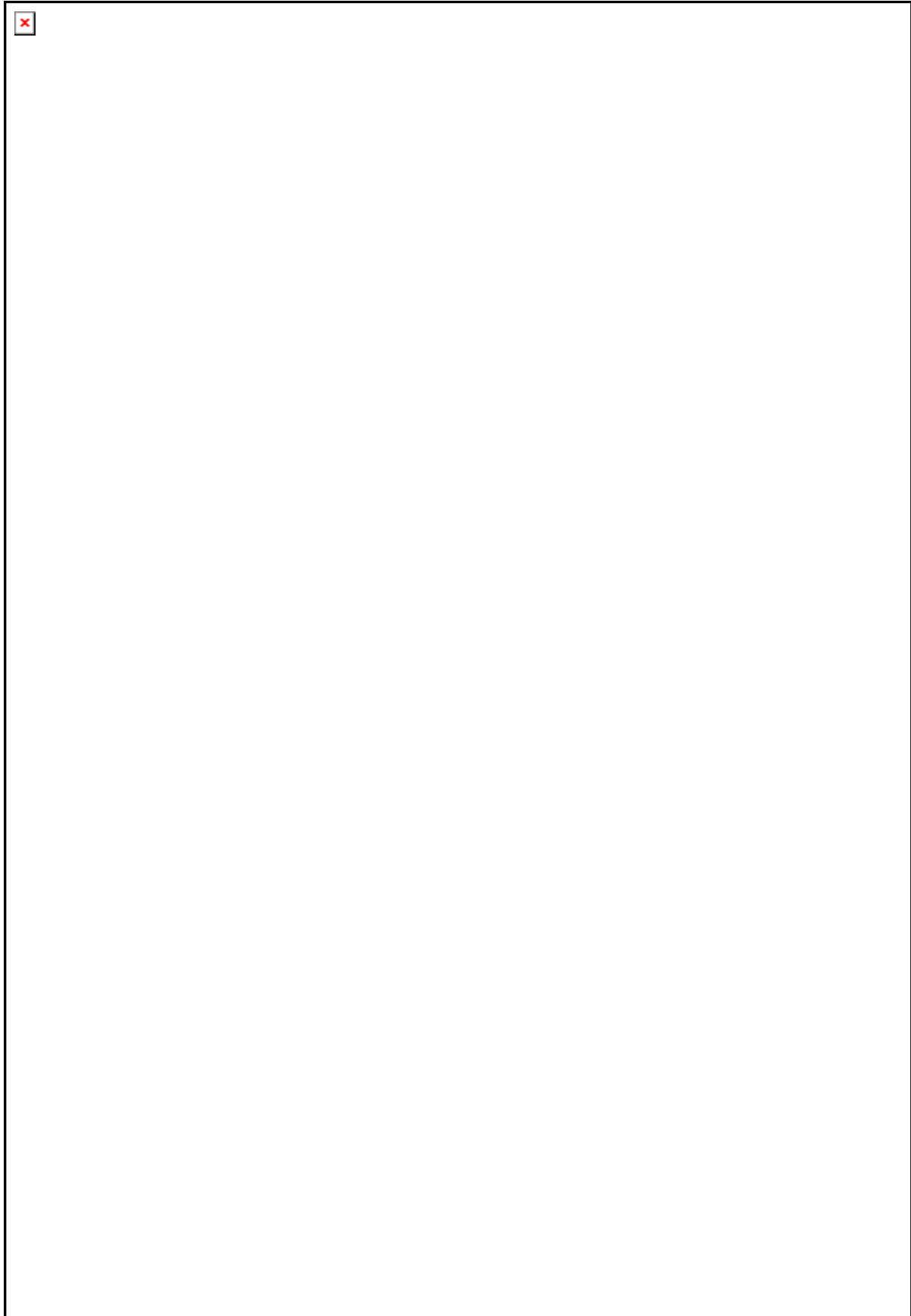

9.10. ELECTRICAL CONNECTIONS

OIL/GAS CRISTAL M1-M2

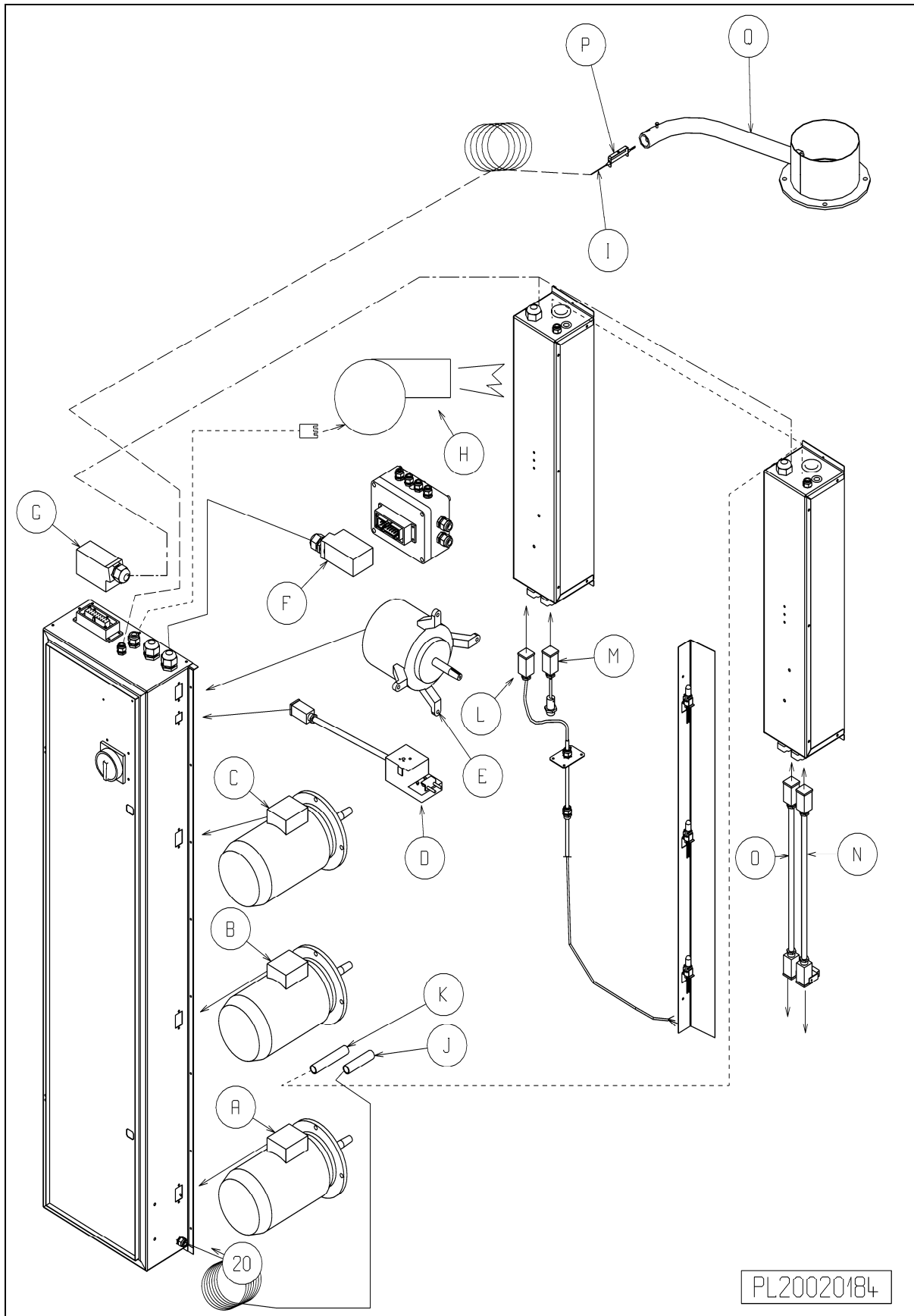

ELECTRIC CRISTAL M1-M2

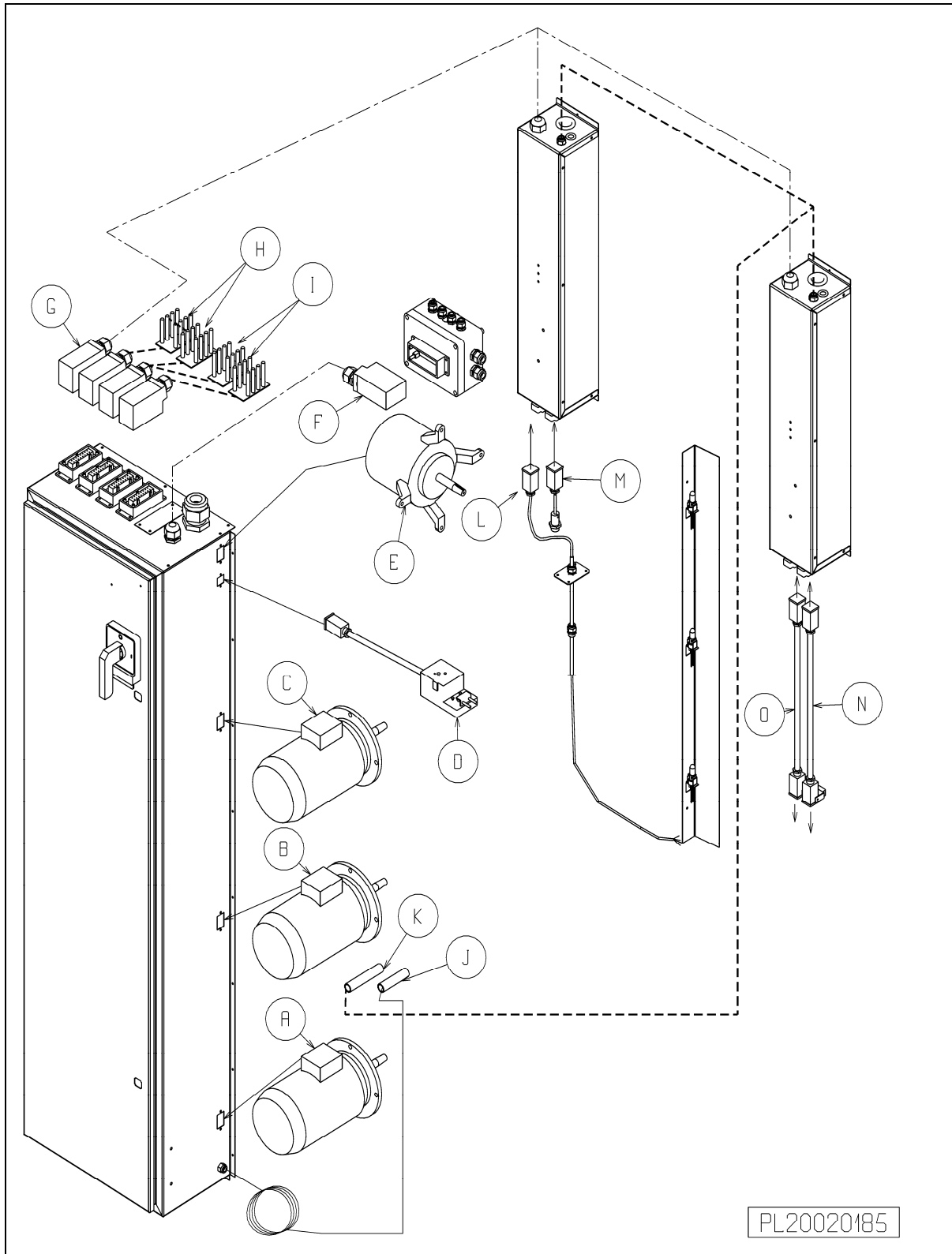

10.ASSEMBLY

1	Bottom	No. 1 page Erreur ! Signet non défini., 121 or 124.
----------	---------------	--

To fix the 4 triangular seals (AF2200005527),
 With on top and bottom a HT black silicone cordon (AF200055070),.

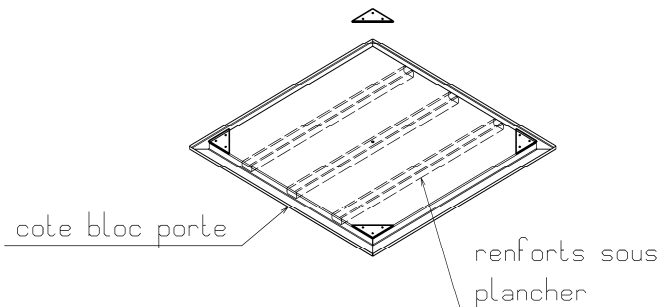

2	Posts	No. 2 and 3 page Erreur ! Signet non défini., 121 or 124.
----------	--------------	--

4 identical on electric ovens. / 2 + 2 on oil/gas ovens.

- Assemble using M8 collar nuts. - DO NOT TIGHTEN -

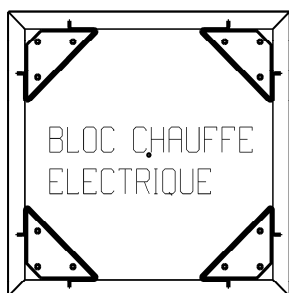

COTE PORTE

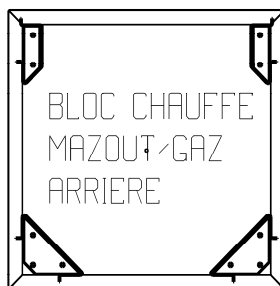

COTE PORTE

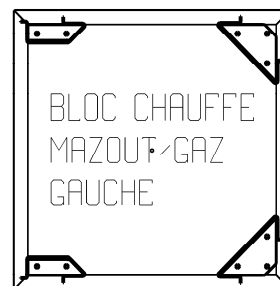

COTE PORTE

P3 BOTTOM (a,b,c)

- The vertical sides of the posts must not protrude from the bottom.

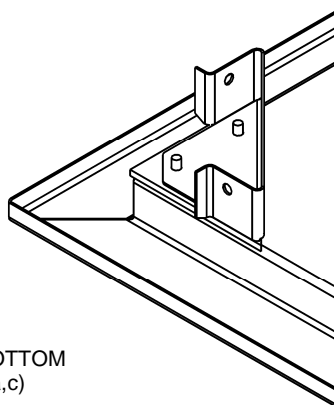

P3 BOTTOM (a,c)

3	Roof	No.4 page Erreur ! Signet non défini., 121 or 124.
----------	-------------	---

- Thoroughly soak the 4 triangular seals with HERMETIC.
- For an oven **with RIGHT door**, place the reducing engine in front
- For an oven **with LEFT door**, place the reducing engine in the back
- Assemble with M8 collar nuts and zinc-coated HM8x25 screws - DO NOT TIGHTEN-

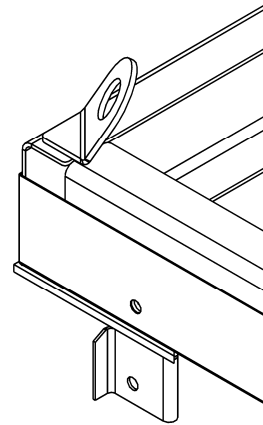

4	First panel	No.7 page Erreur ! Signet non défini., 121 or 124.
----------	--------------------	---

- Check the floor-columns-ceiling diagonals.
- Thoroughly soak the packing on the 4 sides with HERMETIC.
- Apply a continuous joint of SILICONE PUTTY over it.
- Adjust the triangular seals. Apply a joint of SILICONE PUTTY at the junction point.
- Assemble with M8 collar nuts - DO NOT TIGHTEN -

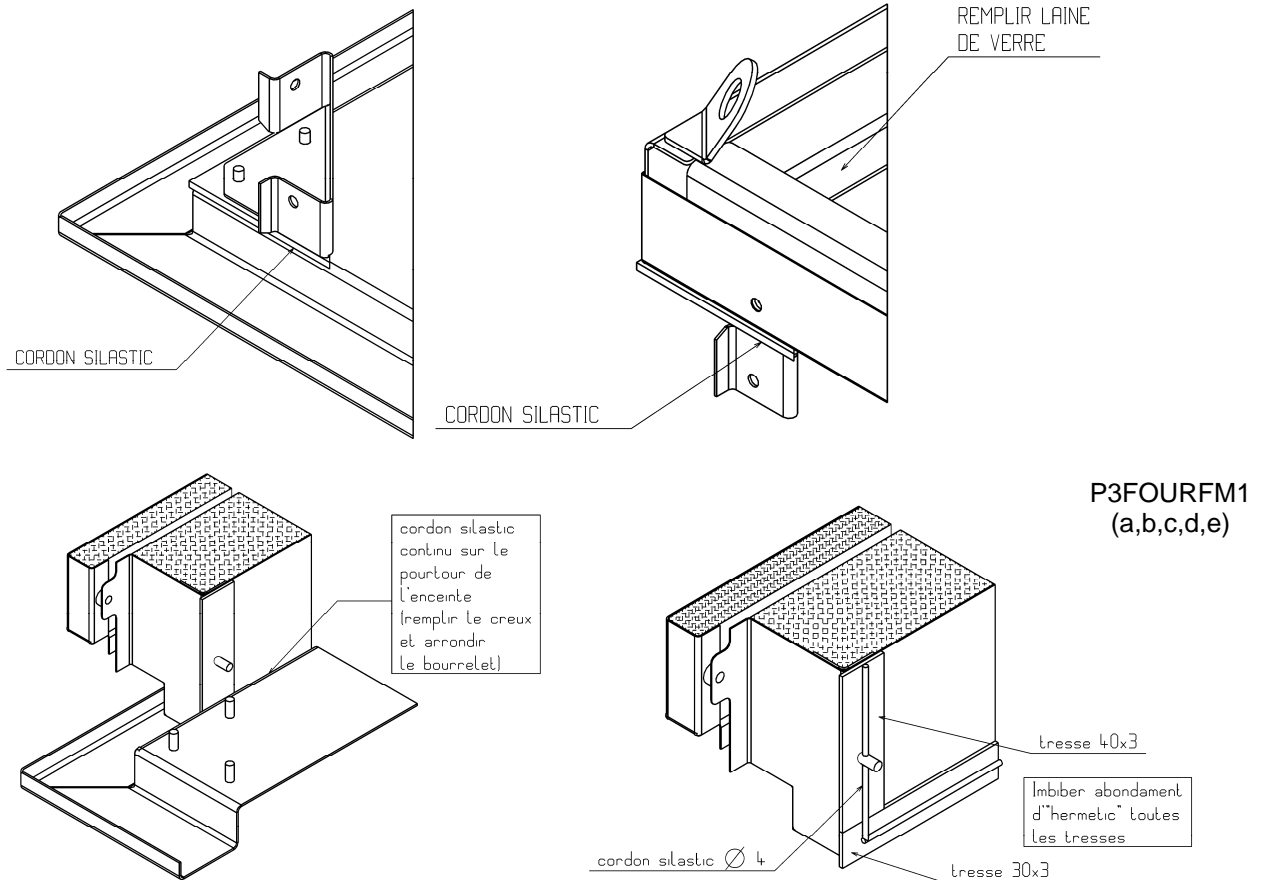

5	Door unit	no. 5 page Erreur ! Signet non défini., 121 or 124.
----------	------------------	--

Same as for 1st panel

6	Heating unit	no.6 page Erreur ! Signet non défini., 121 or 124.
----------	---------------------	---

Same as above.

When handling, always remove the electrical cabinet from the heating unit (temporary fixing, 2 nuts inside).

7	Heat exchanger	Page 129
----------	-----------------------	-----------------

ON OIL/GAS OVENS before closing the enclosure, install the factory-assembled heat exchanger.

Burner side:

- 2 felt seals (no.7) for M1 ovens inside and outside the oven.
- 1 felt seal (no.7) for M2 ovens, inside the oven + 1 felt seal (no.11) on the outside.
- Thoroughly soak them with Hermetic on both sides.
- 1 burner base (5).
- Assemble with 4 HM 8*40 screws (E)
- HM8 collar nuts (F)
- Then install the backplate (8), attached with HM 8*40 screws (E) (only applicable for M2 ovens).
- HM8 collar nuts (F)

Smoke outlet side:

- 1 felt seal (3) inside the oven
- 1 felt seal (3) outside the oven
- 1 smoke outlet (4) pipe diam. 34 towards the back
- Assemble with HM 8*40 screws (E)
- HM8 collar nuts (F)

DO NOT FORGET THE LOWER PIN (10)

8	Squirrel cage frame	no. 2 page , 130
----------	----------------------------	-------------------------

ON OVENS WITH SQUIRREL CAGE:

Before closing the enclosure (2nd panel), install the top frame no.2 and the 2 squares no. 6 with HM 8x16 screws + Grower washer Ø8. To do this, partially release the rack supporting disc inside the oven if necessary. For easier assembly, the squirrel cage must be installed only after assembling the steam generators, phase 21.

No. 1, 2, 3, 10 with HM 12x25 screws, HM12 nut, Grower D.12 washer.

No. 4, with HM 14 nut, M14 thin nut.

No. 5, with F/90 M6x20 screws, M6 collar nut.

No. 7, centre finder on the bottom with HM 10x80 screws.

9	Second panel	no. 7 page Erreur ! Signet non défini., 121 or 124.
----------	---------------------	--

Same as above.

TIGHTEN THE ENTIRE ENCLOSURE -

- Seal the enclosure.
- Complete the roof insulation with rock wool.

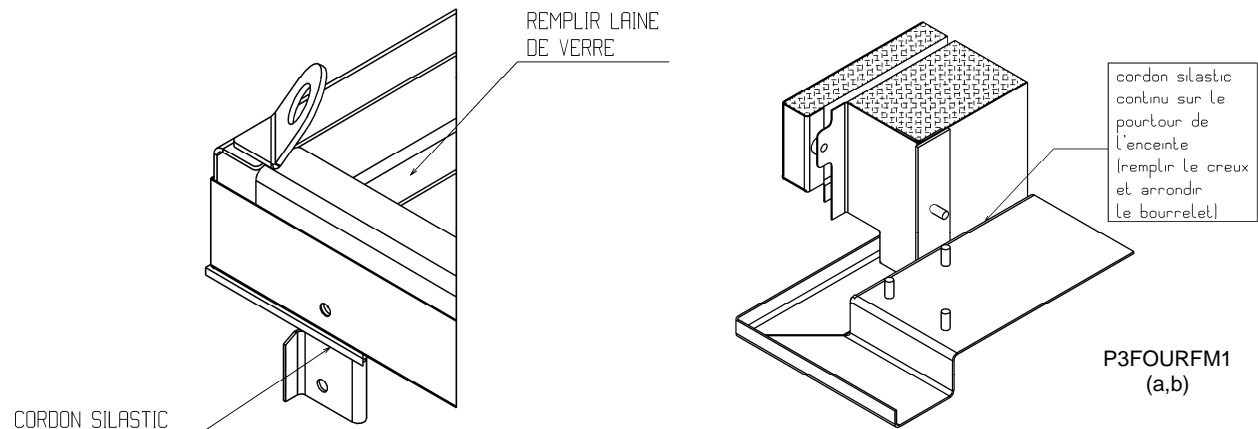

10	Steam exhaust fan	No. 8 page Erreur ! Signet non défini., 121 or 124.
-----------	--------------------------	--

Rear view of the heating unit, steam exhaust fan motor on the left.
On a flat seal, apply a joint of SILICONE PUTTY on the top and underneath.

11	Front heat-insulating sheet	No.9 page Erreur ! Signet non défini., 121 or 124.
-----------	------------------------------------	---

- On all oven models: 2 parts door unit side. Except for oil/gas ovens, side heating unit: 1 part control panel side.
- Insulate the corner post(s) with ROCK WOOL.
- Snap one side in, fasten to the door unit with zinc coated 3.9x10 sheet metal screws.

12	Heating unit side panel	Rep.10 page Erreur ! Signet non défini., 121 ou 124
-----------	--------------------------------	---

For all oven models: 2 parts 40mm above the floor.

For electric ovens: loosen the 5 screws with bakelite insulating washers on each side, snap the panels in between the screws and washers, tighten the screws.

For oil/gas ovens: on each side of the heating unit side screws, place 3 bakelite insulating washers, assemble the panels, fix them temporarily with M6 cover nuts.

13	Electrical cabinet	No.11 page Erreur ! Signet non défini., 121 or 124
-----------	---------------------------	---

- Affix a vertical foam strip on either side of the cabinet front edge, along its entire height.

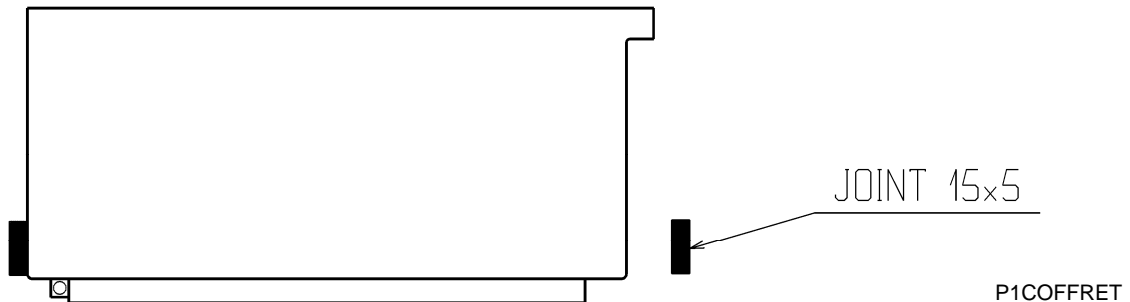

- Attach the cabinet to the heating unit with 6 x M6 collar nuts.

14	Rear cross members	No. 12 and 13 page Erreur ! Signet non défini., 121 or 124
-----------	---------------------------	---

- Attached to the heating unit side panel with stainless steel CB Hc 6x12 screws and stainless steel CB Hc 6x40 screws.

15	Rear angles and plinths	No. 14,15 and 16 page Erreur ! Signet non défini., 121 or 124
-----------	--------------------------------	--

- Attach the plinth to the rear angle then clip the rear angle on to the bakelite insulating washers.
- For oil/gas ovens only: attach plinth no. 14 to rear angle no. 16, then the rear angle to the heating unit bakelite insulating washers. Finally, attach the stainless steel angle over the panel and tighten the M6 cover nuts.

16	Band	no.17 page Erreur ! Signet non défini., 121 or 124
-----------	-------------	---

- Temporarily attach the bands to the rear angles.

17	Front angles	no. 18 and 19 page Erreur ! Signet non défini., 121 or 124
-----------	---------------------	--

- Snap the angle onto plinth no. 14 and band no.17, then attach the angle to the bakelite insulating washers.
- Attach the angle to the stainless steel post of the door frame with 3.9x10 sheet metal screws.

IMPORTANT: Prior to attaching the angle that holds the control panel:

- Connect the light connector
- Assemble the sensor onto the door frame (adjust to 2mm from the door). For left-hand control panel, use the 2 extensions supplied.
- Insulate the angles with ROCK WOOL (except those with front heat-insulating sheet) (no.9).
- Attach the top bands with M6x16 collar nuts.

18	Inclined pan	no.20 page Erreur ! Signet non défini., 121 or 124
-----------	---------------------	--

- Attach to the door frame with HM8x20 stainless steel screws, D.8 tooth lockwasher and Wolfrakot grease.
- Make sure the moving pan does not hit the painted external frame (wedge under the screw if necessary with the washer supplied with it. Check the alignment with the cross member (make it reach the member).

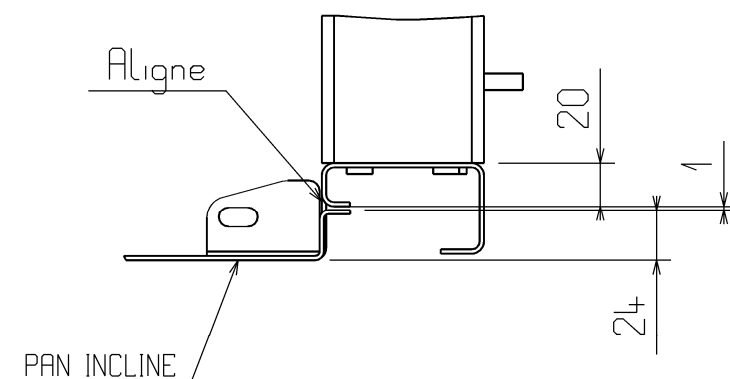

P120005627

- The inclined pan **MUST** be fixed to the floor with plastic pins and wood screws.

19	Intake shutters for electric ovens	Page 127
-----------	---	-----------------

- Install the pan (6) on the bottom of the unit (5)
- Attach the intake sheet (1) to the walls (4) with HM 6x16 brass screws (C), M6 stainless steel tooth lockwashers (D).
- Install the intake shutters (3) in the pan (6) and attach them to the walls (4) with HM 6x16 brass screws (C), M6 stainless steel tooth lockwashers (D).
- Attach the intake shutters (3) to the intake sheet with HM 6x16 brass screws (C), M6 stainless steel tooth lockwashers (D), HM6 stainless steel nuts.

CHECK THE WIDTH OF AIR PASSAGES: 30MM.

20	Intake shutters for Oil/Gas ovens	Page 128 .
-----------	--	-------------------

- Attach the intake sheet (2) to the pan (7) with HM6 x 16 brass screws (C); 6 x 14 flat washer (B); M6 stainless steel nut (A)
- Attach the intake sheet (2) to the top part of the heating unit (1) with 2 HM6 x 16 screws (C); 2 6 x 14 flat washers (B)
- Attach the 2 side pans (5) and (6) and intake shutters (3) and (4) with HM6 x 16 brass screws (C); 6 x 14 flat washer (B); M6 stainless steel nut (A).
- Attach shutters (3) and (4) to the intake sheet (2) and the posts with HM6 x 16 brass screws (C); 6 x 14 flat washer (B)

CHECK THE WIDTH OF AIR PASSAGES: **30 MM.**

21	Steam generators	Page 131,132.
-----------	-------------------------	----------------------

- Attach the generators (no. 3) in the keyholes starting from the bottom.
- Attach the water supply elements (stainless steel pipes no. 2) to the central tee (no. 1), ensuring that the branch connections are directed to the steam generators.
- For electric ovens install the 4 baffles on the lower rear pin (free) of the 4 top and middle steam generators, checking that the water can flow down to the bottom generator.

22	Steam connections	
-----------	--------------------------	--

With flexalu sheath and clamps: seal with silicone putty

- **Door post intake:**
directly from the left side of the roof
- **Door lintel intake:**
by passing the roof on the right

23	Condensate discharge	
-----------	-----------------------------	--

- Connect the intake box exhausts and steam generators as shown below.

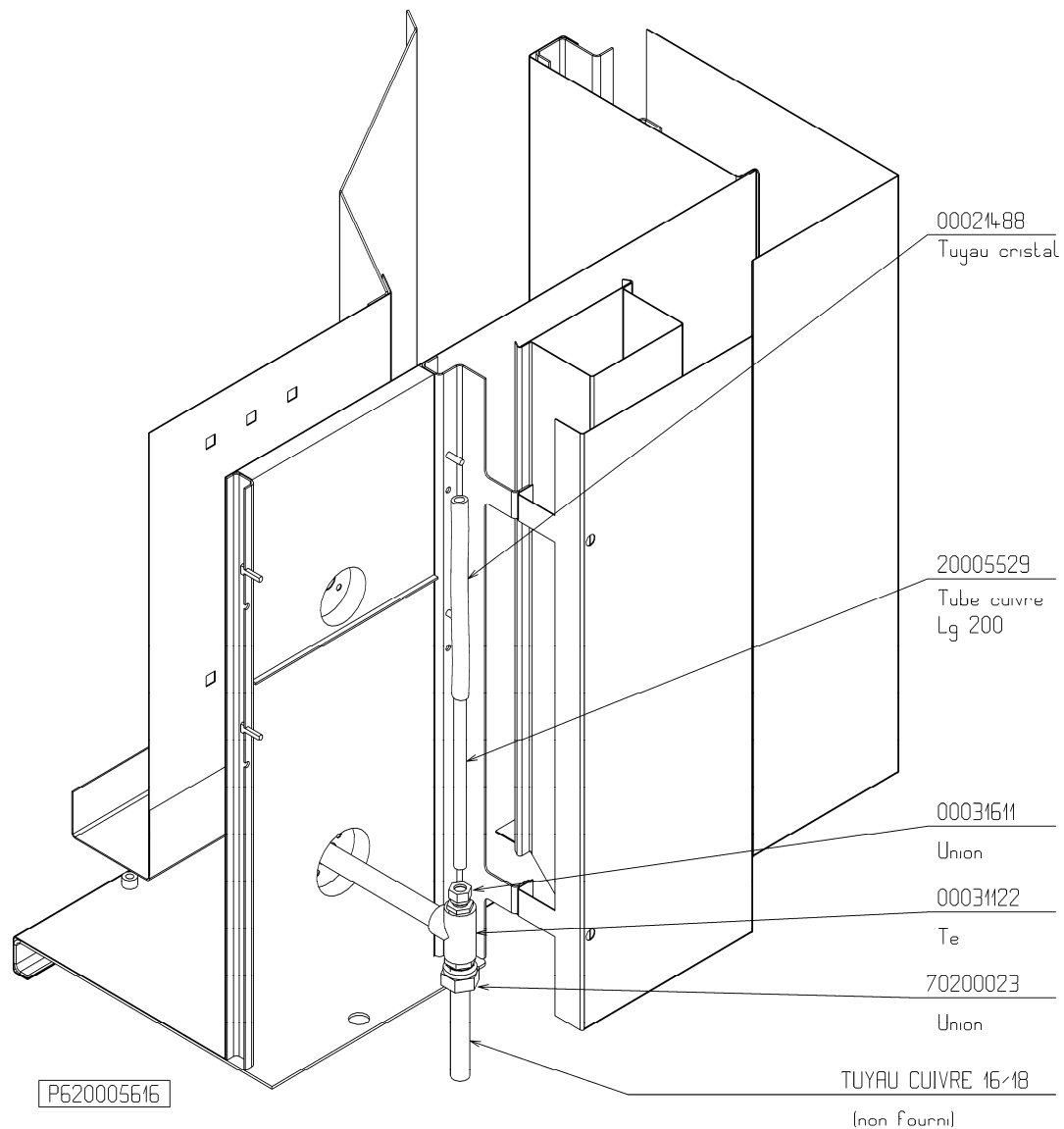

24	Burner	Page 129
----	--------	----------

Oil/gas ovens only:

- Attach the burner to its mount (no 5) sandwiching the 10 mm thick seal (No. 6) and the seal supplied with the burner. Connect the elements - see section 3.2 or 3.8.

25	Electrical connections	Page 133, 134
----	------------------------	---------------

All connectors are fitted with polarizing slots.

ELECTRIC OVEN

- Connect the 3 fan motors (A / B and C) to the main electrical cabinet.
 - The servomotor of the damper actuator (D).
 - The steam exhaust fan motor (E).
 - The 16-pin connector (G) of the front panel.
 - The 16-pin connectors (H) and (I) of the resistor units.
- Connect the 16-pin connector (F) to the roof distribution box.
- Install and attach with silicone putty - see § 26
 - The overheat safety thermostat (J) bulb in the heating unit thermometer pocket (push right in).
 - The temperature regulator thermocouple (K) in the heating unit thermometer pocket (push right in).

IMPORTANT: run the grey cables (19 conductors) through the top side bands so that they do not come in contact with hot oven parts.

- Connect the mains to the main electrical cabinet circuit breaker.

OIL/GAS OVEN

- Connect to the main electrical cabinet:
 - The 3 fan motors (A / B and C).
 - The servomotor of the damper actuator (D).
 - The steam exhaust fan motor (E).
- Connect the 16-pin connector (F) to the roof distribution box.
- Connect the 6-pin plug to the burner (H).
- Install and attach with silicone putty: see § 26
 - The overheat safety thermostat (J) bulb in the heating unit thermometer pocket (push right in).
 - The temperature regulator thermocouple (K) in the heating unit thermometer pocket (push right in).
- Install the smoke safety thermostat bulb on the mount.

IMPORTANT: run the grey cables (19 conductors) must through the top side bands so that they do not come in contact with hot oven parts.

- Connect the mains to the main electrical cabinet circuit breaker.
- Insert the mount into the tube (flower bulb) and tighten the M4 screw to block it.

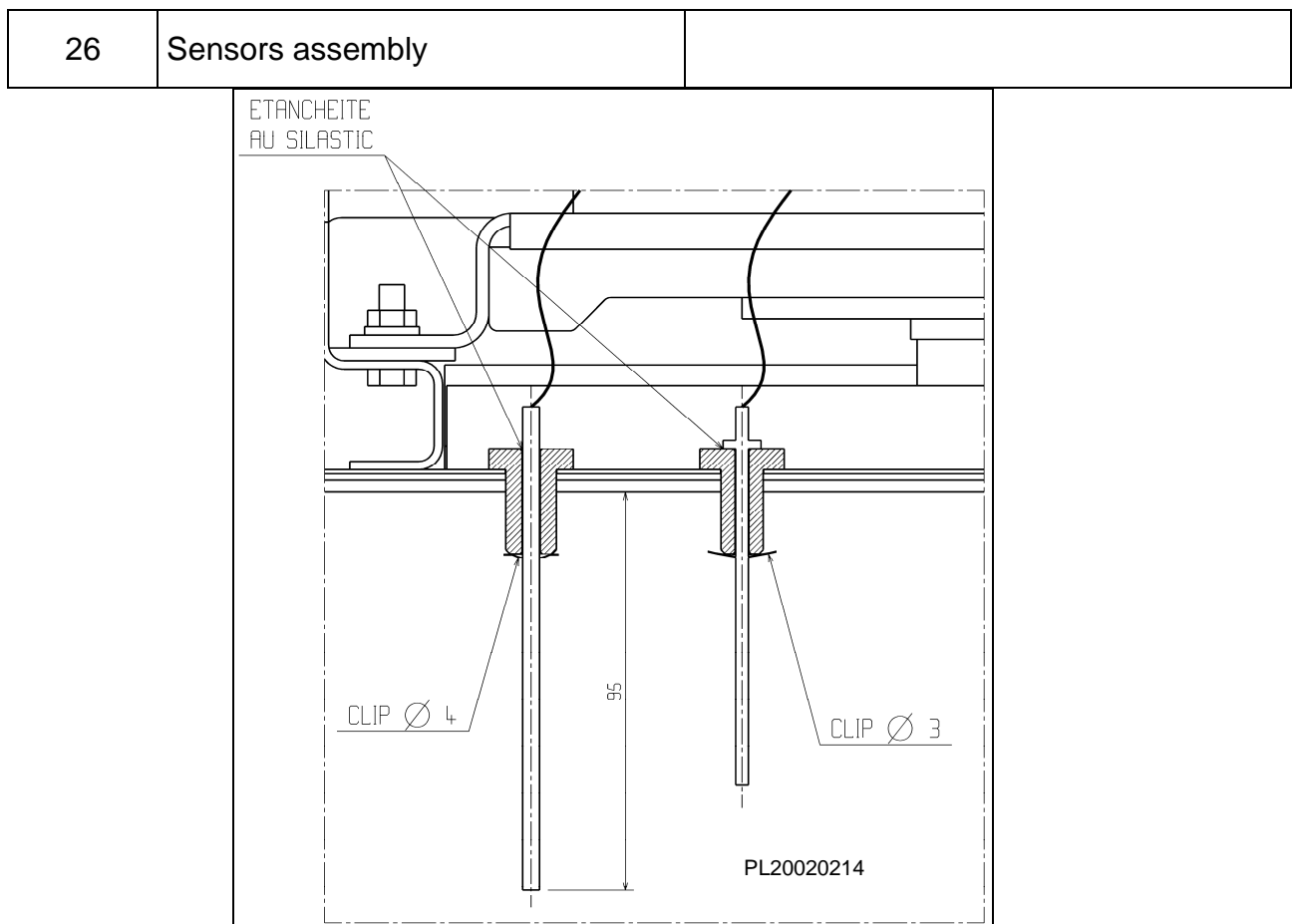

11. ADJUSTMENTS

1	Rack drive disc	
----------	------------------------	--

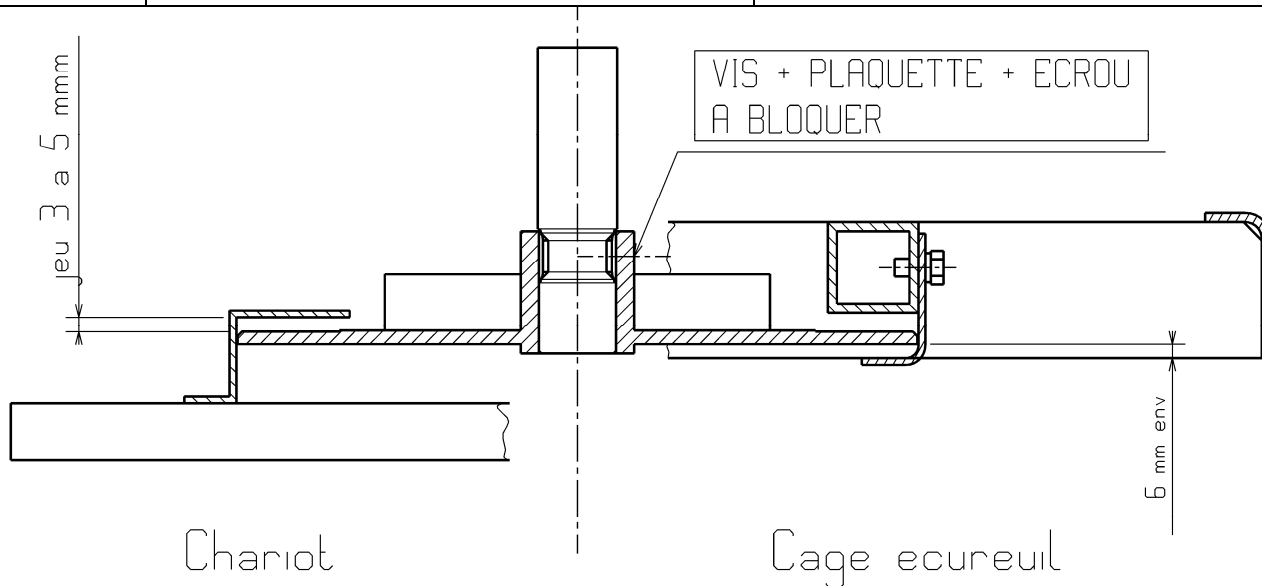

2	Time delays	
----------	--------------------	--

- R6** Time delay for steam injection time
- R4** Time delay for stopping the fan impellers after steam injection
- R5** Time delay for steam extraction when the door opens

OVEN FRONT

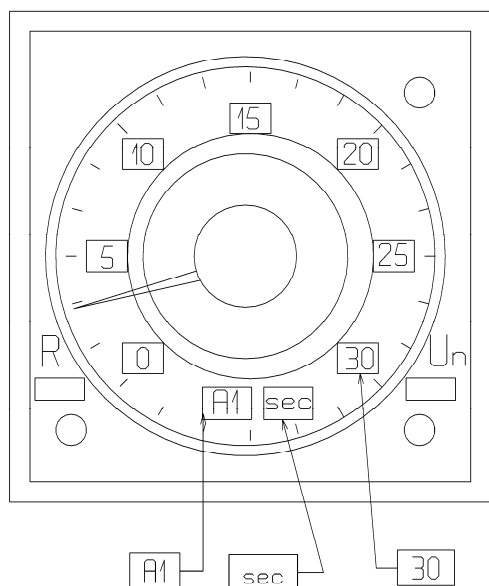

ELECTRICAL CABINET BACK

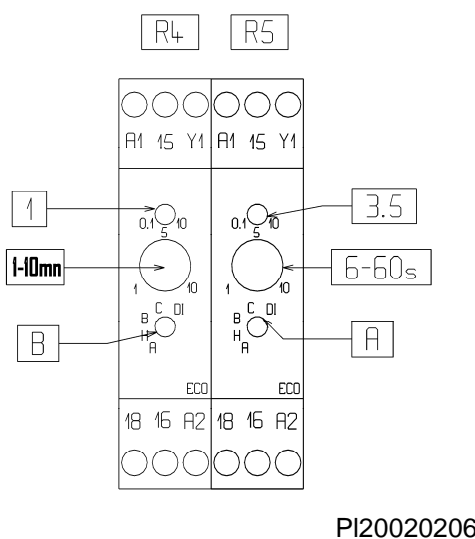

12. STARTING THE OVEN

12.1. MOTOR DIRECTION OF ROTATION

PRELIMINARY OPERATIONS:

- **CHECK** the direction of rotation of impellers (anti-clockwise inside the oven) by pressing an impeller motor contactor KM6.
- If necessary, reverse 2 phases on the MAINS SUPPLY of the disconnection switch.
- Then press the KM4 contactor once to check that the direction is UP.
- Set the switch to the ON position on the oven's main electrical cabinet. (Position 0: oven off Position 1: oven on)
- Close the oven door.
- Set the timer to 'bake' mode.
- Set the temperature regulator to the required temperature.
- Press the ON button 1, the indicator lights up (steam generator off)
- The oven is pre-heating.

12.2. ADJUST THE DOOR UNLOCKING CABLE

Yoke in the low position (rack down)

Cable end with 15 mm clearance

12.3. CHECK THE DIRECTION OF THE DAMPER

Check the open and closed positions are not inverted (damper closed with vertical pins).

If necessary, invert the position by turning the arrow 0-1 on the damper motor.

12.4. INSTALL THE CLADDING

Rear panel: no. 22 page **Erreur ! Signet non défini.**, 121 or 124

Attach the side panels and cross members with CBHC M6x12 stainless steel screws

Also place a screw on each visible bushing.

Top belt: no. 24 page **Erreur ! Signet non défini.**, 121 or 124

Attach with HM6x20 stainless steel screws and M6 collar nut.

13. CHANGES FOR INSTALLING THE SQUIRREL CAGE

On a standard oven

Change the standard roof (sheet 1)

a - Disconnect pinion no.2 from shaft no.1

- 3 screws - 3 nuts - 3 safety washers

- Move it from A to B, raising the shaft inside the baking chamber by approx. 70 mm (sheet 2)
- lock the 3 screws in the 3 flat collar nuts + nuts + washers

b – Dismantle ball thrust bearing no.3

- Assemble the spacer ring onto the yoke (CHECK THE DIRECTION)
- Reassemble the ball thrust bearing in reverse order.

Modify the standard bottom

- Attach the locating pin to the bottom with the HM10x80 screw
- Grease the screw and the pin using HT BARRIERTA grease

Assemble the squirrel cage

- Adjust the drive disc height

- Don't forget to tighten the screw and block it with the safety washer + nut.

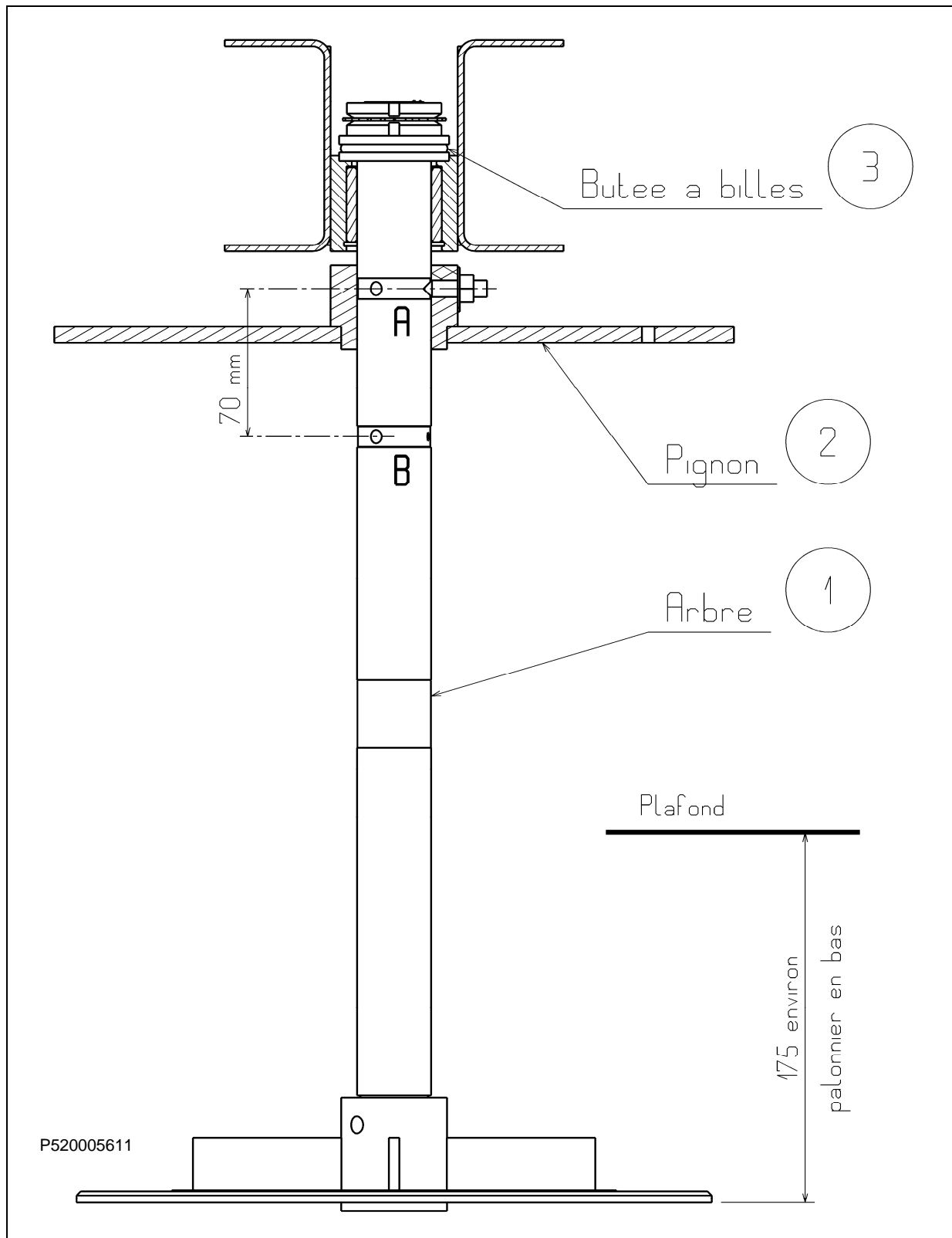

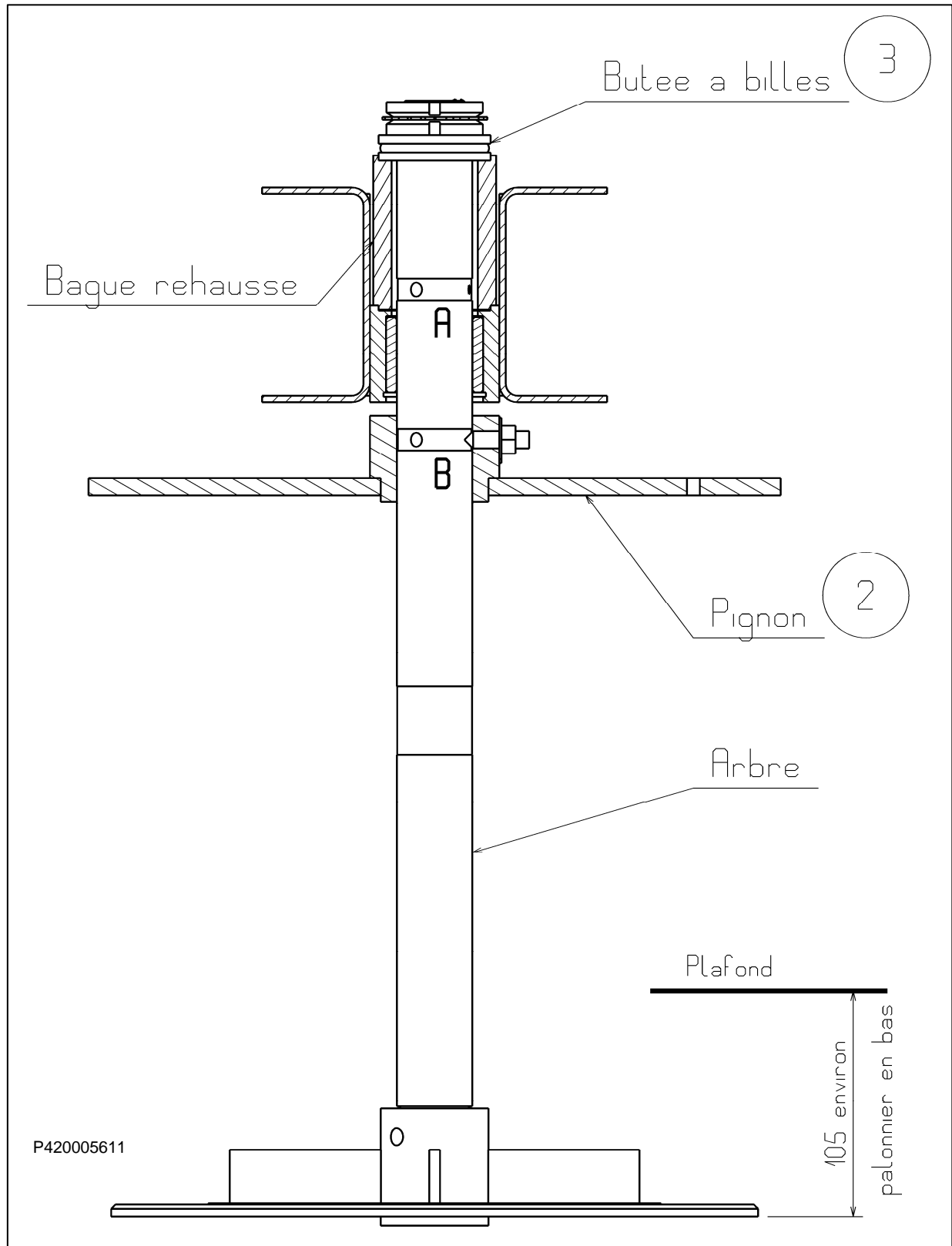

14. CHANGES TO SETUP

- **Electric ovens** are versatile, the heating unit can be installed equally at the back left or right without having to change the components.
- **Oil/Gas ovens** are different for each setup:
 - rear heating unit (standard)
 - left heating unit
 - right heating unit
- Adaptation kits allow for changing a rear heating unit (standard).
 - a. left heating unit
 - b. right heating unit.

In this case, it is necessary to remove the control panel from the front right angle to reassemble it onto the new left angle. Use the extension cables supplied to connect the detector and the door light.



DEALER'S STAMP